

Seametrics

jWAVE™

Portable Transit Time Ultrasonic
Flow Meter Instructions



General Information

General Information Page 3
 Specifications Page 3
 Meter Features..... Page 4
 App Features Page 4
 Dimensions Page 5
 Technology Page 5
 Do’s and Don’ts Page 5

App Installation

Getting Started Page 6
 Location Setup..... Page 6
 Parameter Setup Page 7

Flow Meter Installation

Straight Pipe Recommendations Page 8
 Full Pipe Recommendations..... Page 9
 Flow Meter Orientation Page 9
 Transducer Spacing..... Page 10
 Power Considerations..... Page 10
 Installing the Flow Meter..... Page 11

Operation

Collecting Your Data..... Page 12
 Data Logging..... Page 12

Troubleshooting

Problems Page 15
 Probable Causes..... Page 15
 Things to Try..... Page 15

This device complies with Part 15 of FCC Rules and Industry Canada license-exempt RSS standard(s). Operation is subject to the following two conditions: (1) this device may not cause harmful interference, and (2) this device must accept any interference received including interference that may cause undesired operation. Contains FCC ID: XDULE40-S2, Contains IC: 8456A-LE4S2. CAN ICES-1/NMB-1; CAN ICES-3 (B)/NMB-3(B)



Meet the **Seametrics jWAVE**. Capture accurate and reliable flow readings with your mobile device, with less hassle and in less time—wherever you need a flow or volume measurement.

No wires. No bulky electronics box to lug around. Your ultrasonic flow meter hardware installs on the outside of your pipe in a snap—and senses through the pipe wall. Your mobile device displays readings and helps you set up the hardware.

The jWAVE Flow Meter solution starts with the jWAVE App (downloadable from the app stores) and works on both iOS and Android devices.

The jWAVE Flow meter is a compact, strap-on transit time ultrasonic transducer device. The jWAVE operates by alternately transmitting and receiving a burst of sound energy between two transducers. It then wirelessly transmits flow measurements to your mobile device. Use

the portable data logger to conveniently record flow for as long as 14 days or as little as one minute.

The jWAVE is highly portable. Just bring the rechargeable clamp-on meter in its lightweight, weatherproof case, along with a tablet or smartphone (iOS or Android). Bluetooth connectivity replaces wires, and the jWAVE App guides you through setup.

The convenient cam cleats let you mount the flow meter on any pipe in seconds—no cumbersome clamps required.

Bi-directional readings are transmitted to your mobile device for display and your location’s settings are stored in the jWAVE App, ready for reuse.

When you are done, simply release the cleats, then take the compact meter on to your next location.

Specifications*

| | | |
|-----------------------------|---|---|
| Pipe Size | 2" to 20" | |
| Pressure Drop | Zero | |
| Materials | Body | Anodized aluminum channel, acetal end housings and feet |
| | Mounting Straps | EPDM |
| Temperature | Ambient & Fluid | -20° to 150° F (-29° to 65° C) |
| Display | English and metric units provided on app | |
| Flow Operation Range | Bidirectional; 0.1 ft/s to 20 ft/s (0.03 m/s to 6 m/s) | |
| Turndown | 200:1 | |
| Accuracy | 1% to 2% of reading (typical) | |
| Repeatability | 0.5% | |
| Output Signal | Wireless Bluetooth 4.0 (BLE) connectivity to iOS ¹ or Android ² device | |
| Power | Rechargeable battery (up to 12 hours), 1W max, 150mA max current, 5 "AA" NiMH 6V pack with thermistor, 5 month shelf life | |
| Power Adapter | For recharging battery - must use the 12W USB power adapter supplied with the jWAVE | |
| Installation | 10 pipe diameters upstream, 5 diameters downstream for optimal performance (typical) | |
| Environmental | IP65 | |

*Specifications subject to change • Please consult our website for current data (www.seametrics.com).

¹The following iOS devices support Bluetooth 4.0 (BLE): iPhone 4S and later, iPad 3rd generation and later, iPad mini, iPad Air, and iPod Touch 5th generation.

²If you have an Android device, check the settings on the device or specifications for the device to be sure it supports Bluetooth 4.0 (BLE).

Meter Features

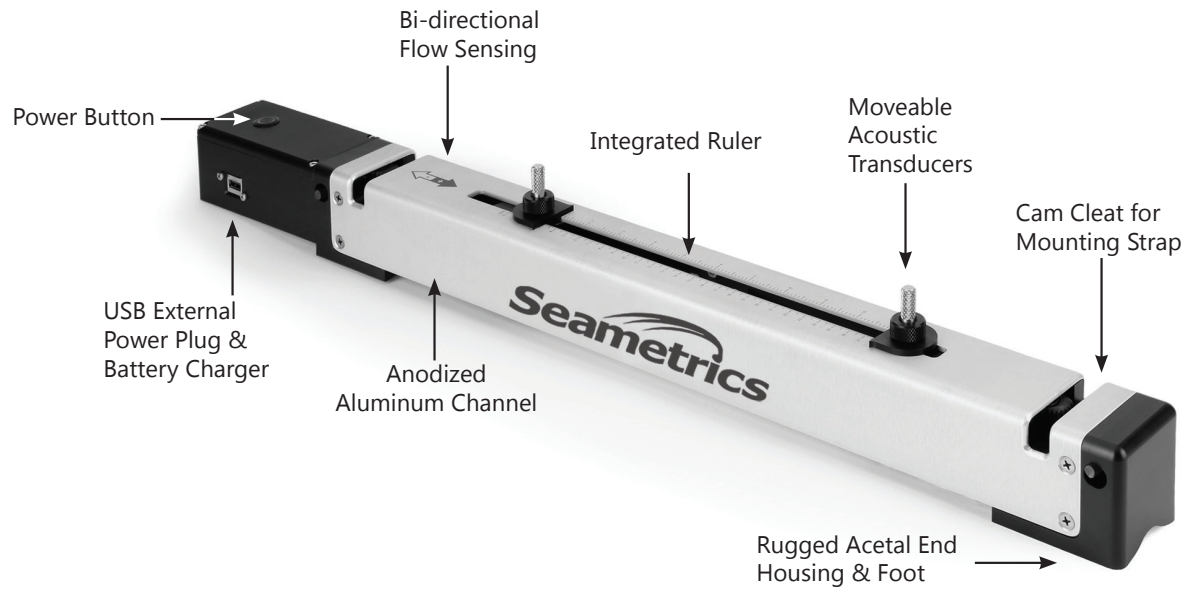

App Features



Interactive smart phone/tablet control app—iOS or Android

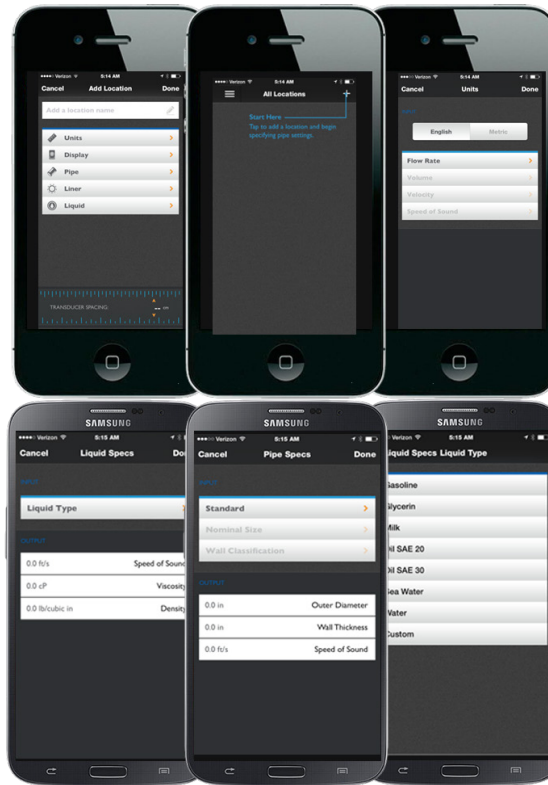

- Handy built-in pipe specifications—or add your own
- Save location information
- Drag and drop output selection
- English or metric units
- Select liner and liquid types—or define your own.
- Easy-to-use data logging

Dimensions

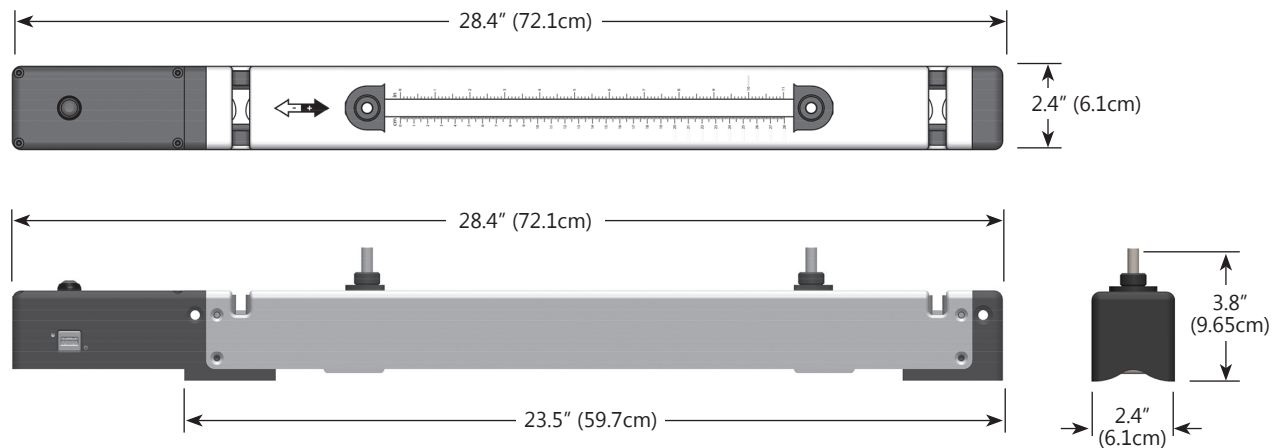

Technology

The transit time flow meter operates by alternately transmitting and receiving a burst of sound energy between the two transducers.

The burst is first transmitted in the direction of fluid flow and then against fluid flow.

Since sound energy in a moving liquid is carried faster when it travels in the direction of fluid flow (downstream) than it does when it travels against fluid flow (upstream), a differential in the travel times will occur. The sound's travel time is accurately measured in both directions and then used to compute the flow rate.

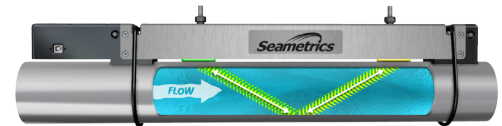

Sound waves can bounce in many directions as they travel through various materials. The more the sound waves scatter, the fewer actually reach the second transducer. The jWAVE uses sophisticated methods to maximize transducer efficiency, thus allowing the unit to run on very low power. Focusing of the sound wave is also important to ensure it reaches the second transducer without degrading. This is accomplished by accurately spacing the transducers to allow for optimum sound transit between transducers. The jWAVE app computes this spacing based on the pipe size, pipe material, and type of liquid.

Transit time technology works best in clean or mildly dirty water or fluids with minimal turbulence or flow distortion.

Do's and Don'ts

- Do** charge your jWAVE at least once a month.
- Do** store your jWAVE in a dry, inside area when not in use.
- Do** store your jWAVE fully charged.
- Do** keep your jWAVE in its protective case when transporting to prevent damage.
- Do** gently clean the transducer pads regularly with isopropyl alcohol to prevent hardening and build up of used coupling gel.

- Don't** charge with any charger other than the 12W charger supplied. Other chargers may damage the jWAVE.
- Don't** store, transport, or use your jWAVE where the device may exceed 150°F (65°C)—battery may leak or explode!
- Don't** bang or drop the jWAVE on hard objects or surfaces.
- Don't** nick the transducer pads.

Getting Started

Begin by downloading the Seametrics jWAVE App to your iPhone™, Android phone, or other Bluetooth enabled mobile device from the Apple Store™ or Google Play™. (Note: On an iPad, you must select iPhone Only in the app store.) If you do not have automatic updates enabled on your device, be sure to update your app when notified that there is a new version available.



jWAVE



jWAVE
for Agriculture

NOTE: Be sure your mobile device supports Bluetooth 4.0 (BLE).

The following iOS devices support Bluetooth 4.0: iPhone 4S and later, iPad 3rd generation and later, iPad mini, iPad Air, and iPod Touch 5th generation.

If you have an Android device, check the settings on the device or specifications for the device.

Location Setup

Launching the app lands you on the locations screen. The app always begins with this screen at launch, making it easy to access previously saved location settings.

Begin by tapping on the add location (+) button.

Give your location a name and then set the specific parameters for that location. Each location's settings are stored in the jWAVE App, ready for reuse.

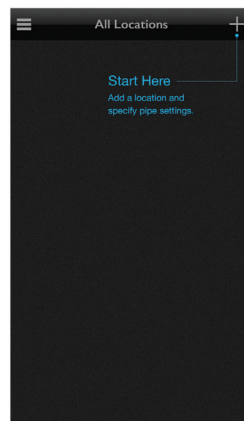

+
Add location

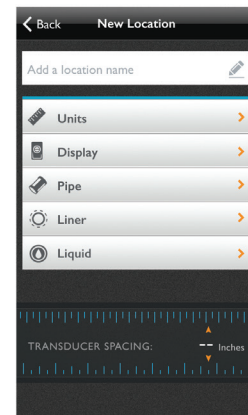

Name your location

Parameter Setup

Use the handy parameter selection screens to set your units of measure and display preferences. Conveniently select pipe, liner, and liquid specifications from lists of pre-loaded values. Don't see the right option? Add your custom values!

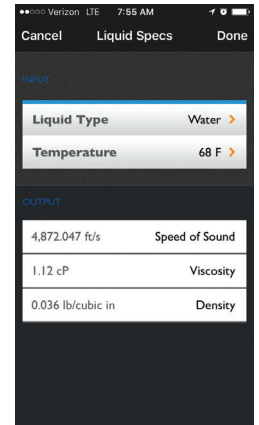
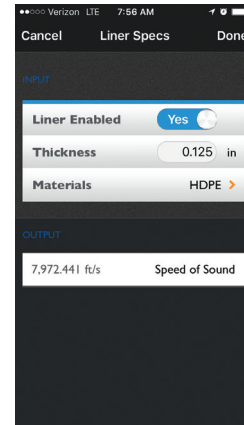
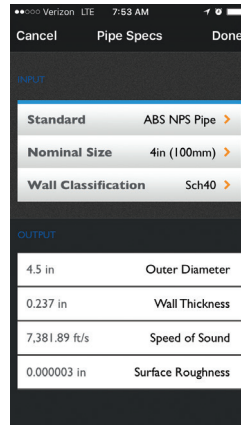
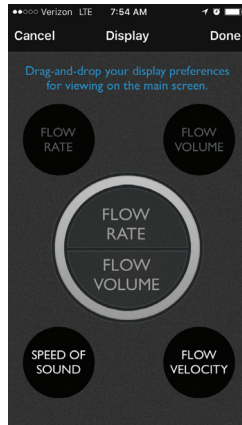
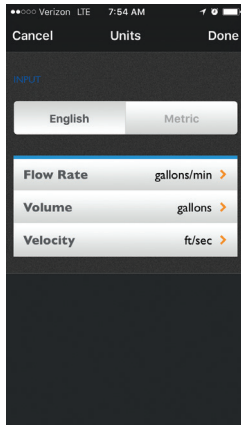

Units
Toggle between **English** and **metric** units of measure.

Select **Flow Rate**, **Volume**, and **Velocity** from our pre-loaded values.

Display
The main screen displays two outputs. Drag and drop the two outputs that you rely on most to display on the main screen.

Pipe
Select **Pipe Type**, **Size**, and **Wall Classifications** from our pre-loaded values or add custom values by selecting Custom under Pipe Type. When entering a custom type, you must supply the outer diameter, wall thickness, speed of sound through the pipe material, and the surface roughness—enter zero if unknown roughness.

Liner
Switch between liner and no liner. When selecting **Liner Enabled**, enter **Liner Thickness** and choose **Liner Material** from our pre-loaded list or add custom values. When adding a custom material, you must enter the speed of sound through that material.

Liquid
Select **Liquid Type** and **Temperature** from our pre-loaded list of values or add a custom liquid type. When adding a custom liquid, you will need to enter the speed of sound through that liquid, the viscosity, and the density.

Straight Pipe Recommendations (X = diameter)

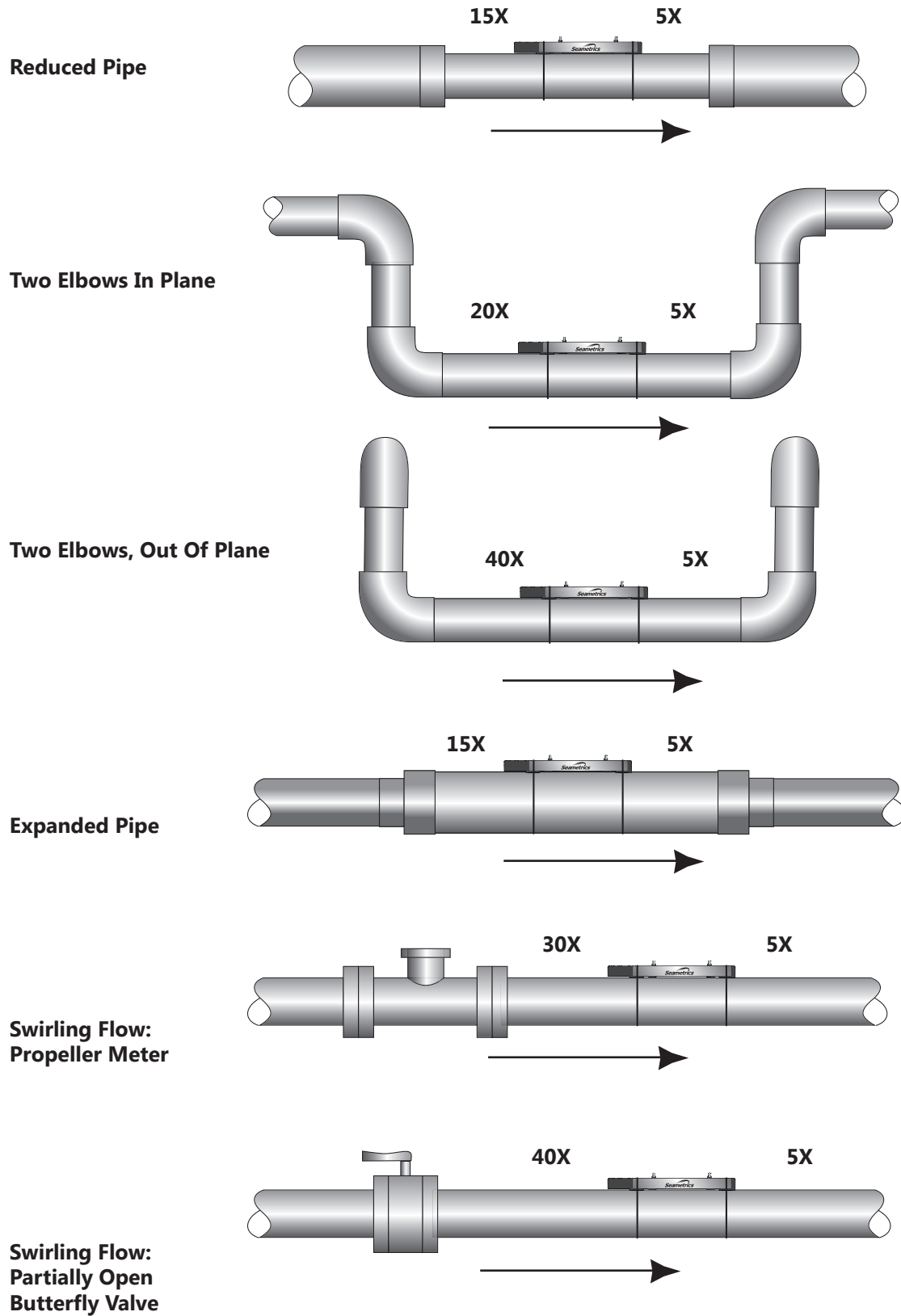

Full Pipe Recommendations

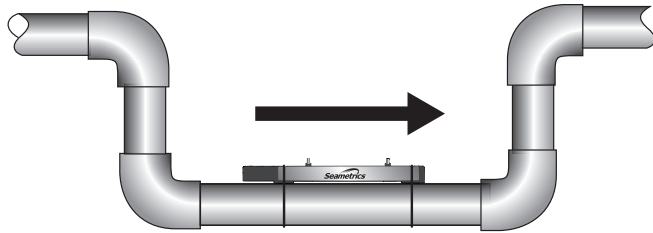

Recommended:
Keep pipe full at meter for accuracy

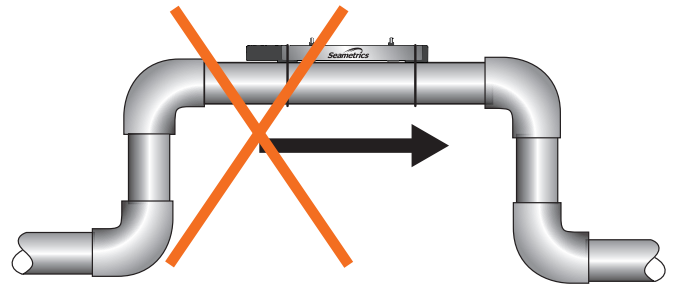

Not Ideal:
Allows air pockets to form at meter

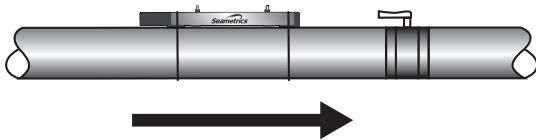

Recommended:
Keeps pipe full at meter for accuracy

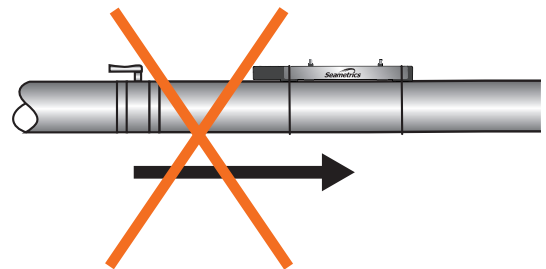

Not Ideal:
Post-valve cavitation can create air pocket

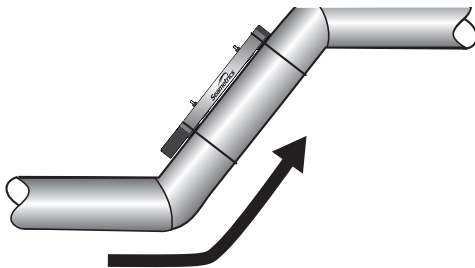

Recommended:
Allows air to bleed off

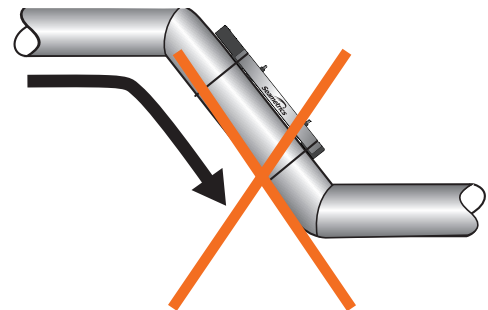

Not Ideal:
Air can be trapped

Flow meter Orientation

Horizontal (3 o'clock or 9 o'clock position) is the preferred installation orientation, since it avoids problems with trapped air and sediment.

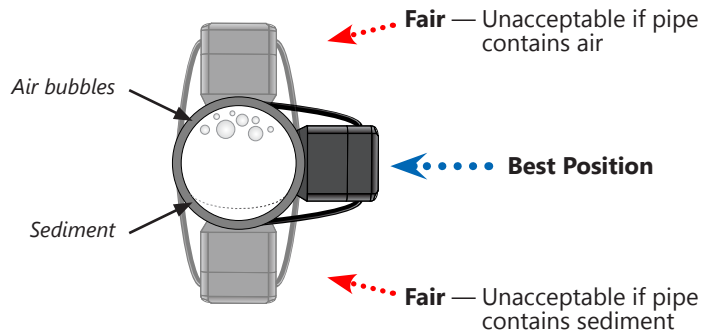

Transducer Spacing

Once you entered your parameters in the previous section, the app automatically computed the proper transducer spacing. This is shown at the bottom of the main app screen.

The next step is to adjust the transducer spacing on the flow meter, as follows:

1. Rotate the black knob to unlock the horizontal motion for each transducer.
2. Move the transducers to the specified transducer spacing by sliding them along the integrated ruler. *Note: It is not necessary to start at zero on the ruler, so long as the actual spacing is correct.*
3. Lock into place using the black knobs. This is important to prevent the transducer spacing from moving when mounting the flow meter!

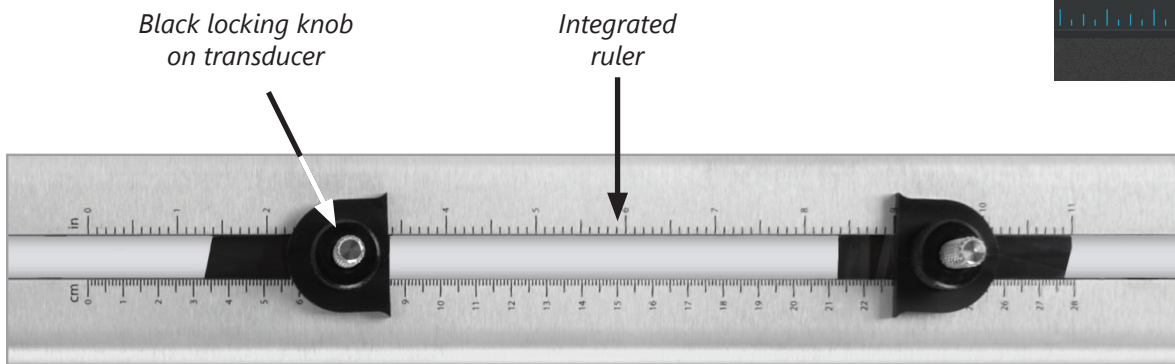
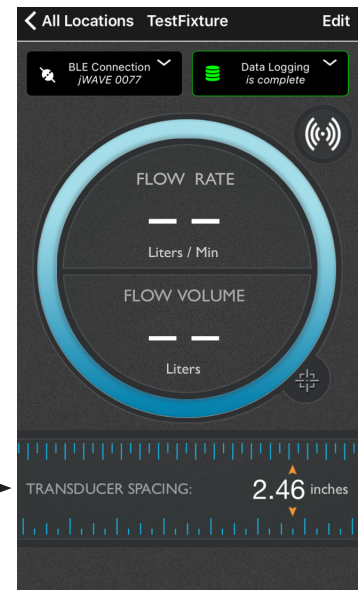

Power Considerations

Your jWAVE Flow meter battery has been fully charged at the factory before shipping and is ready to go.* When it's time to recharge the battery, the app will let you know.

When using the datalogging function and recording for more than 12 hours, the jWAVE must be connected to a power source, such as a portable USB power bank or a USB power adapter connected to an external power source.

* On a full charge, the jWAVE will have a shelf life of up to five months. It is a good idea to charge the unit for a full five hours if it hasn't been used for a month or two. On a full charge the meter should operate for up to 12 hours of continuous use. Note that if the battery is flat, the power button LED will blink rapidly for five seconds and then the meter will turn off.

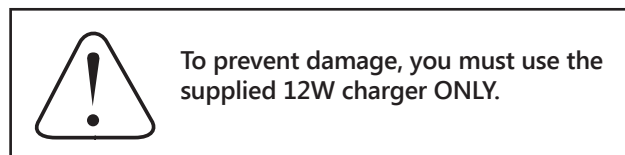

Installing the Flow meter

Once the transducer spacing has been set and locked in place, you are ready to install the flow meter on your pipe.

1. Rotate the silver knobs counter clockwise until they stop. This raises the transducers up above the meter footings.
2. Apply coupling gel liberally to the transducer faces, covering the entire bottom face of each transducer.
3. Place flow meter on pipe, assuring that the footings are flush with the pipe and the meter is aligned with the axis of the pipe.
4. Strap the meter to pipe with the mounting straps, clamping the straps into the cam cleats. Hand tighten only!
5. Rotate silver knobs clockwise to press transducers onto the pipe. Hand tighten only until seated firmly.

Warning: Tightening too much can lift the meter away from the pipe, causing incorrect readings.

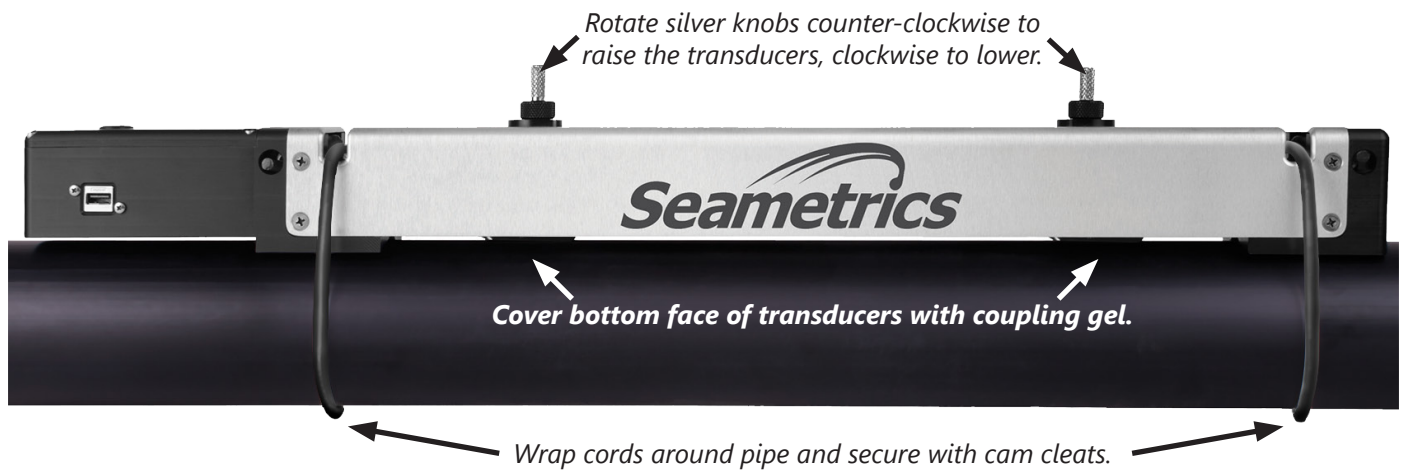

Collecting Your Data

Be sure the app is running on your mobile device.

Turn on power to the flow meter by pressing the power button on the left top of the meter.

A steady LED indicates that power is on. The LED will flash if the meter is charging on external power. *(Note: Older units may not flash.)*

The app will display a list of all jWAVEs within its range. Tap the one you are currently using.

(Note: Your app will check the flow meter to be sure it has the most recent programming. If there is a newer version available, it will give you the option of updating the meter. This may take three to five minutes.)

Your flow data will display on the jWAVE App.

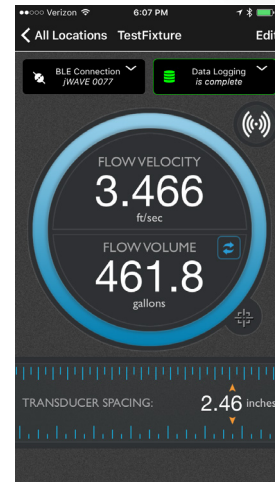



When you are done collecting data, snap the cords out of their cam cleats and you are ready to move on to your next location. The next time you return to this location, the jWAVE App will remember your settings.

Data Logging

The purpose of the jWAVE's built-in data logger is to record flow for a specified period of time. It may be used to conveniently record flow for as long as 14 days or as little as one minute. While conveniently battery powered, the jWAVE has limited memory. Thus, only one data log may be used at any one time. As the jWAVE data logger uses Bluetooth (BLE) to transfer data from the flow meter to the mobile device, data transfer speed is limited by BLE, which is not designed to transfer large data sets. Transferring the maximum sized data set will take up to 5 1/2 minutes.

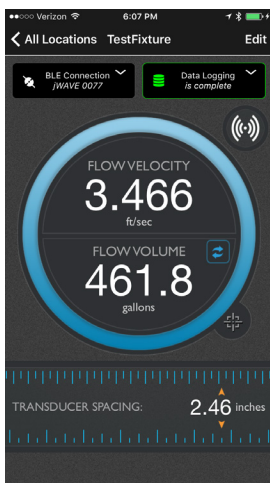
All data logging functions are accessed by tapping the Data Logging button in the measurement view.





The jWAVE's data logger stores only one data set at any time, selecting "Rec" (which creates a new data log) will write over the existing data log. A message appears when selecting the "Rec" button indicating that the existing data log will be over-written if a new data log is started and gives the user the ability to continue with the new data log or to cancel.

Making a Recording

- Connect to the meter with the jWAVE App.
- Tap the Data Logging button to access the data logger features.
- Using the slider bar in the app's data logger setup view, set the recording time. (See Explanation of Recording Times on the next page.)
- Tap "Rec" to start the recording. Data will start recording on the meter. You can disconnect the mobile app during recording. The meter will turn off when done to save power, unless still connected to the app.
- To stop recording prior to completing the time period, connect the jWAVE App to the meter, tap the Data Logging button, and tap "Stop."

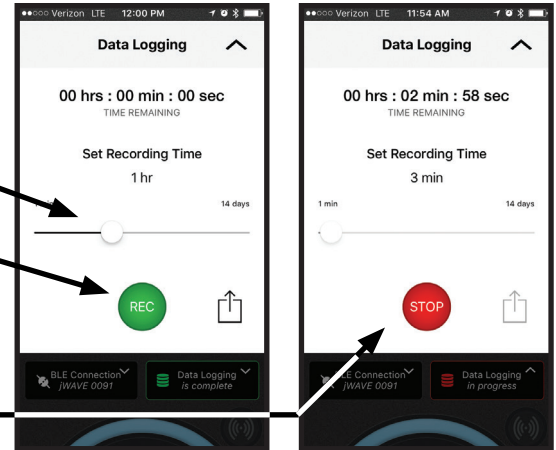

The status of the data logger is indicated by the color and text of the data logger setup button, located in the measurement view. If data logger is active, the button is outlined in red, shows a red disk drive, and displays "in progress." If the data logger is completed, the button is outlined in green, shows a green disk drive, and "complete." The data logger setup view also displays the remaining recording time for conveniently checking progress of data logging.



Uploading Data

Data is stored on the flow meter and may be retrieved at any time. To upload data, the data logger must be either complete or stopped and the app must be connected to the flow meter. Data is uploaded using the "share" button located to the right of the "Rec" button. Uploading the maximum sized data set may take up to 5 1/2 minutes.

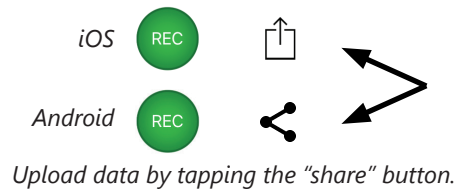

iOS users: If you want to quickly review your data at any time, tap the "share" button, and then tap Quick Look. This displays the data log in a spreadsheet for immediate viewing on your mobile device.

Sharing Data

You only need to upload the data log once from jWAVE. Once the data is uploaded, it may be shared any number of times without additional uploading, until a new data log is started. Tap the "share" button to share the data by a number of methods, email, text, AirDrop, Google Drive, etc., depending on what is available on your mobile device. Shared data is formatted in a CSV file (comma delimited file). The file name is unique and contains both the date and time that the data log was started as well as the location name. Setup information such as the date and time the data log was started, the number of samples, sampling period, and location name are located at the top of the data file. The data is arranged in rows, where each row contains a single flow measurement including sample number, time stamp, flow rate, velocity, volume, and quality. The data file can be viewed or printed as a text file or formatted using most spreadsheet and database programs, such as Microsoft® Excel or Access.

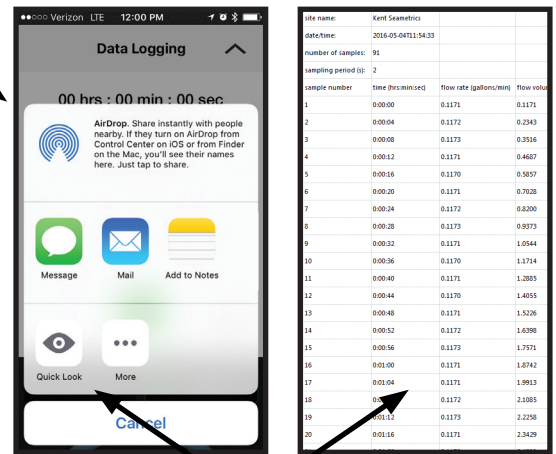

iOS users: Tap "Quick Look" for immediate viewing of your data. (Tap the upper left corner of the screen to close the Quick Look view.)

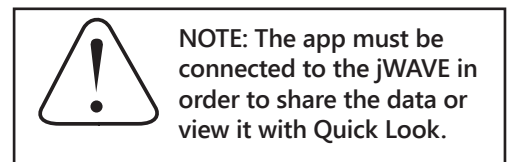

Explanation of Recording Times

The sampling rate (time between each recorded flow measurement) and total number of recorded measurements is controlled by the jWAVE. The maximum possible number of flow measurements is 3750 and each includes five values—flow rate, total, velocity, time stamp, and quality. The maximum sampling rate is two seconds.

The jWAVE data logger will attempt to maximize the sampling rate, based on the your selected recording time. For example, if you select to record flow for one minute, then the jWAVE maximizes the sampling rate at two seconds and will record 31 flow measurements (covering a total of 60 seconds).

If you select to record flow for four days, then the jWAVE again attempts to maximize the number of flow measurements; however since there is not enough memory to record flow every two seconds for four days, it configures the sampling period to maximize the number of flow measurements. For the case of four days, the jWAVE sets the sampling period at 92 seconds giving you a total of 3716 flow measurements. (Note that because the jWAVE uses whole seconds to set the sampling period, it is not able to always provide exactly 3750 samples to cover the specified recording time.)

| Length | Sample Period |
|----------|------------------------------|
| 1 minute | 2 seconds |
| 1 hour | 2 seconds |
| 10 hours | 9 seconds |
| 1 day | 23 seconds |
| 4 days | 92 seconds (1 min. 32 sec.) |
| 10 days | 230 seconds (3 min. 50 sec.) |
| 14 days | 322 seconds (5 min. 22 sec.) |



When recording more than 12 hours, the jWAVE must be connected to an external power source, such as the USB power adapter supplied with the jWAVE.

| Problem | Probable Causes | Things to try... |
|---------------------------|---|--|
| Battery not charging | Using wrong power supply | Use the supplied 12W charger/power supply |
| No signal | Incorrect setup Air in pipe Corroded rusty pipe | Confirm pipe settings Rotate meter to 3 o'clock position Remove air Relocate meter to another location where there is no air Relocate meter to clean section of pipe. If no clean section is available, move meter to other locations until a signal is found—try to find a section of pipe with less corrosion or rust. |
| Can't find iOS App | Searching under iPad only Device does not support Bluetooth 4.0 (BLE) | In Apple Store, select iPhone only from menu Use a device that supports Bluetooth 4.0 (BLE) |
| Can't find Android App | Device does not support Bluetooth 4.0 (BLE) | Use a device that supports Bluetooth 4.0 (BLE) |
| Can't find jWAVE with app | Device does not support Bluetooth 4.0 (BLE) Bluetooth is not turned on Not in range | Use a device that supports Bluetooth 4.0 (BLE) Turn on Bluetooth Move closer to the jWAVE |



Seametrics • 19026 72nd Avenue South • Kent, Washington 98032 • USA
(P) 253.872.0284 • (F) 253.872.0285 • 1.800.975.8153 • seametrics.com

LT-14234r8.0-20160608
6/8/16