

TX800-Series

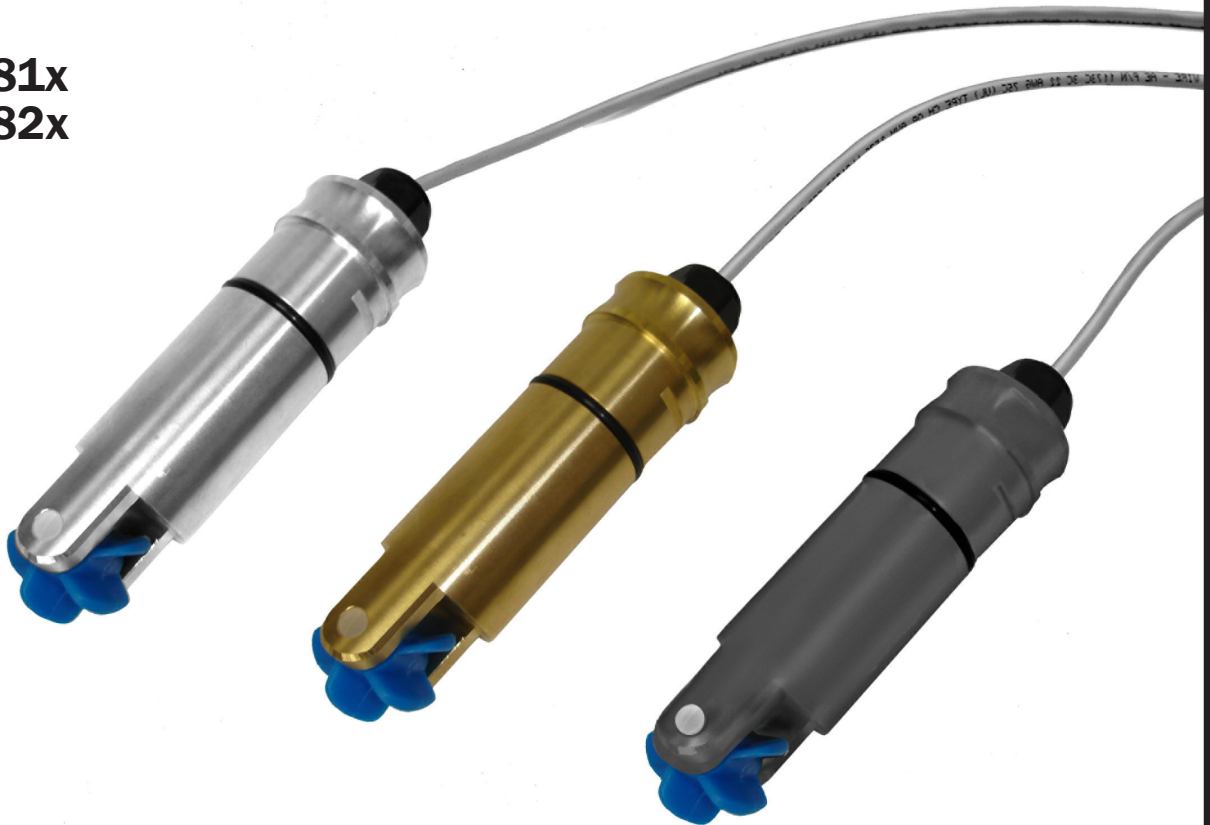

FLOW SENSOR INSTRUCTIONS

- TX81x
- TX82x



TX800-SERIES FLOW SENSOR INSTRUCTIONS

ISO 9001:2008
CERTIFIED COMPANY

General Information

General Information, Features Page 3
 Specifications..... Page 4

Installation

Fitting Installation, Distorted Flows, Meter Installation, Orienting the Meter Page 5
 Straight Pipe Recommendations Page 6
 Full Pipe Recommendations..... Page 7

Connections

FT430, FT440 Page 8
 FT450, Connecting to PLC's Page 9

Operation and Maintenance

Modularity, Output, Fittings, Minimum Flow, Flow Rate Tables, Calibration (“K-Factor”) Page 10
 Rotor Replacement, Signal Troubleshooting, Sensor Replacement..... Page 11
 Parts List Page 12

Troubleshooting

Problem, Probable Cause, Things to Try..... Page 13

TABLES AND DIAGRAMS

Features Page 3
 Specifications..... Page 4
 Distorted Flows, Orienting the Meter Page 5
 Straight Pipe Recommendations Page 6
 Full Pipe Recommendations..... Page 7
 Connection Diagrams..... Page 8-9
 Flow Rate Table..... Page 10
 Rotor Replacement..... Page 11
 Parts Explosion, Parts List Page 12
 Troubleshooting Page 13

The TX800-Series are insertion turbine meters designed for use in 1-1/2" to 8" pipe. High-quality jewel bearings and precision shafts ensure long life and low friction. Available in 316 stainless steel, brass and PVC, sensor bodies are machined from solid rod for maximum low-flow performance. The TX800-Series use special fittings that ensure ease of installation and correct depth setting in the pipe.

The rotation of the turbine is detected by a non-drag Hall-effect sensor. Output is a pulse-type square wave, which can be sent long distances (up to 2,000 feet) without a transmitter. This

signal can be connected directly to Seametrics controls and displays, as well as PLC's, counters, and computer cards.

Seametrics TX800 meters are ideal for chemical proportioning applications. If no display is required, a simple divider such as the PD10 provides adjustable pump pacing. For rate and total display, as well as pump pacing, the FT420 flow indicator can be mounted directly on the TX800-Series, or remotely on a wall or panel. The FT415 offers a battery-operated rate/totalizer where power is not available.

Features

 **Caution:** U-clip must be installed before use.

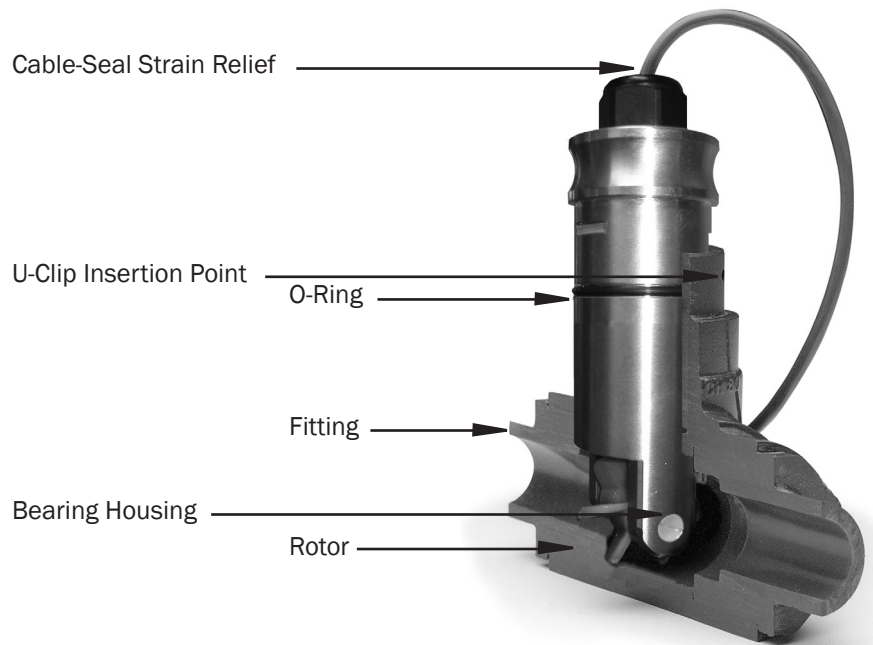

Specifications*

Pipe Sizes		EX11x/15x: 3" to 10"	EX21x/25x: 10" to 48" (up to 72" optional)
Materials	Shaft/Fitting	316 SS or Brass	
	Electrodes	Hastelloy	
	Electrode Cap	PVDF	
	Housing	Cast powder-coated aluminum	
	Valve Assembly (15x/25x only)	Bronze (stainless optional) with bronze ball valve	
	O-Ring (15x/25x only)	EPDM	
Power	Full Power	12-25 Vdc, 250 mA	
	Low Power	12-25 Vdc, 40 mA average with 250 mA peaks	
Flow Range		0.28 to 20 ft/sec (0.08 - 6.09 m/sec)	
Fitting Size Required		EX11x/21x	EX15x/25x
		1-1/2" FNPT	2" FNPT
Temperature	Ambient	0° to 160° F (-17° to 72° C)	
	Fluid	32° to 200° F (0° to 93° C)	
Pressure		200 psi (14 bar)	
Minimum Conductivity		20 microSiemens/cm	
Calibration Accuracy		+/- 1% of full scale	
Output		Square wave pulse, opto isolated, 550 Hz@20ft/sec 6mA max, 30 Vdc forward flow standard; reverse flow optional	
Empty Pipe Detection		Software, defaults to zero flow	
Regulatory		CE	

*Specifications subject to change. Please consult our website for the most current data (www.seametrics.com).

Fitting Installation

TX800-Series meters require special fittings. The meter fitting must first be installed in the pipeline. Straight pipe of at least ten times the diameter upstream of the meter and five diameters downstream is strongly recommended in order to achieve proper accuracy. These are minimum values. As the diagrams on the the next page will show, you may need more straight run under specific adverse circumstances.

If you can't provide enough run to smooth out the turbulence caused by valves, fittings, and changes in direction, some decrease in accuracy may result. This does not mean that the flow meter's reading is meaningless, however. In some applications (for instance, where the flow meter is part of a control system, operating a valve or controlling chemical addition), a repeatable reading may be more important than a highly accurate one.

TX800-Series PVC meter tees are supplied with some upstream straight pipe. The length provided may be less than ten diameters upstream and five diameters downstream. It is not advisable to connect directly to the end of these fittings with a flow-disturbing device such as a valve or elbow. If possible, straight pipe should be added to the upstream end of these fittings.

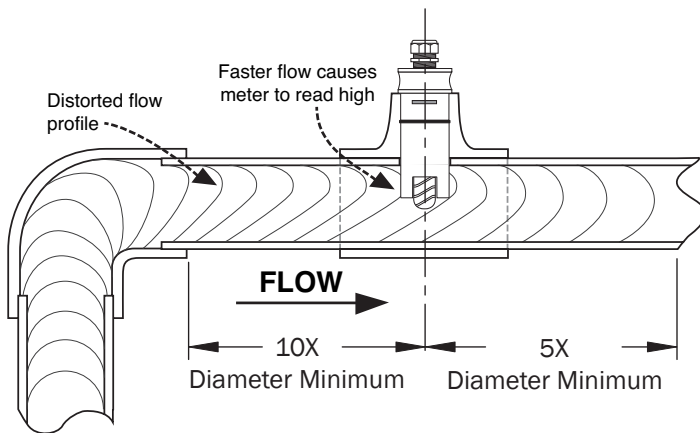

Distorted Flows

A PVC fitting is usually installed by solvent welding. The stainless steel and brass meter fittings have female pipe threads, requiring the appropriate male threaded fittings. Saddle fittings (size 3" and above) require a hole to be cut in the pipe. The recommended hole size is 1-3/4".

Meter Installation

After the meter fitting is installed in the pipeline, the meter can be installed in the fitting. After noting the direction of the flow arrow, press the meter into the fitting as far as it will go. Retain the meter in place by inserting the U-clip. The pin can be installed from either side. It may be necessary to rotate the probe back and forth slightly to start the pin into the slots on the probe. Slide the pin in as far as it will go.

Horizontal (3 o'clock or 9 o'clock position) is the preferred installation orientation, since it improves low-flow performance and avoids problems with trapped air and sediment. (See Orienting the Meter diagram below.) Bottom (6 o'clock), top (12 o'clock), and vertical pipe installations are all acceptable if required by the piping layout.

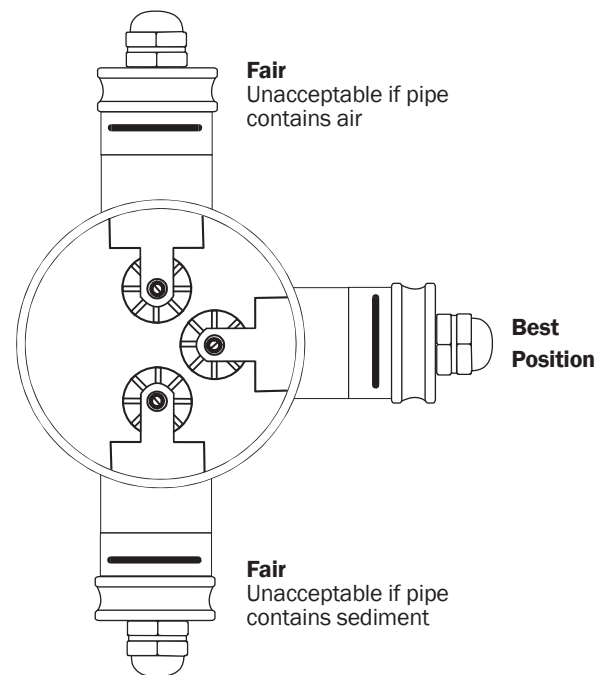

Orienting the Meter



Caution: Never remove the u-clip retainer when the pipe is under pressure. Always remove pressure from the pipe before you attempt to remove the meter. Removal under pressure may result in damage or serious injury.

Straight Pipe Recommendations (X = diameter)

Reduced Pipe

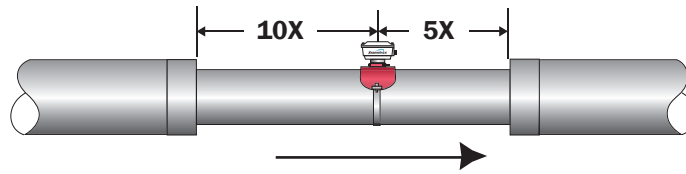

Two Elbows In Plane

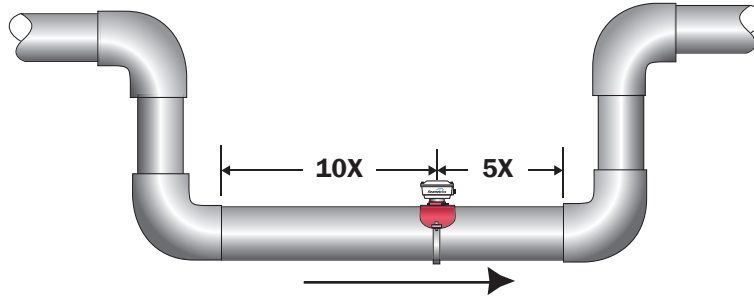

Two Elbows, Out Of Plane

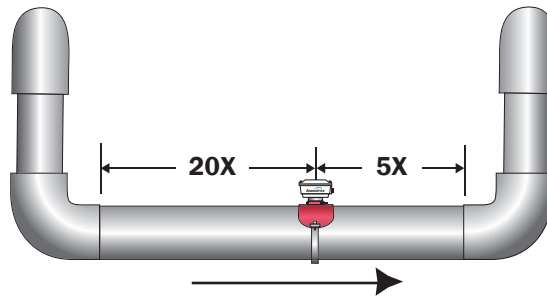

Expanded Pipe

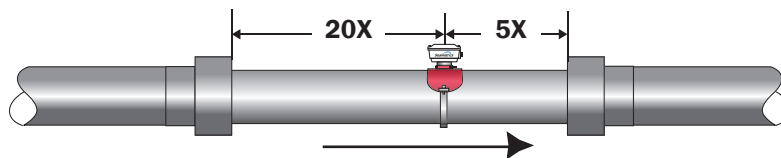

Spiral Flow

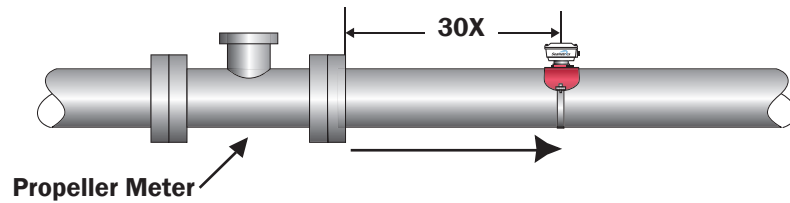

Propeller Meter

Swirling Flow

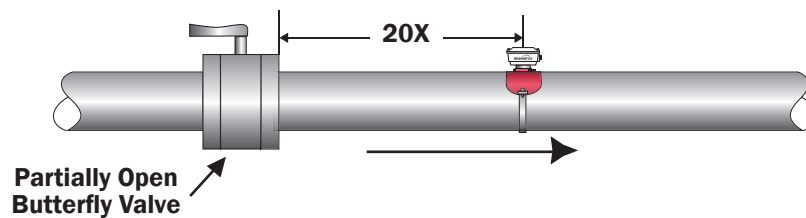

Partially Open Butterfly Valve

Full Pipe Recommendations

Possible Problem

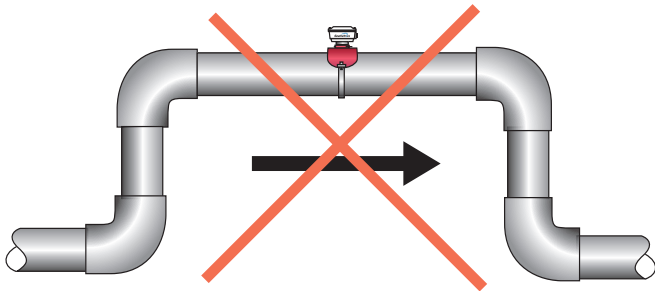

Allows air pockets to form at sensor

Better Installation

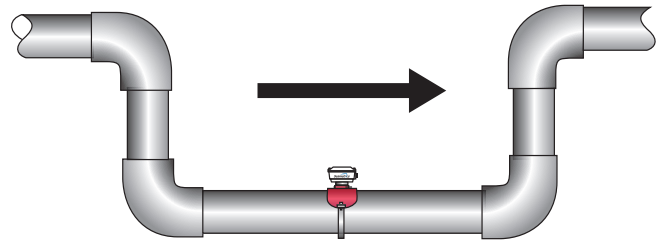

Ensures full pipe

Possible Problem

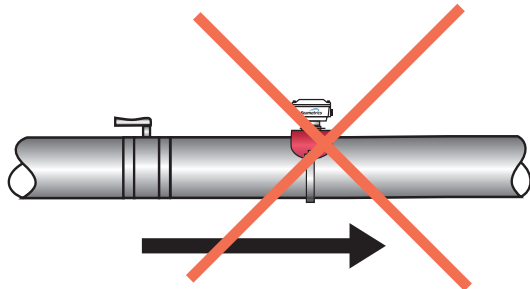

Post-valve cavitation can create air pocket

Better Installation

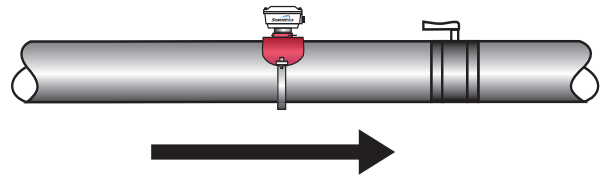

Keeps pipe full at sensor

Possible Problem

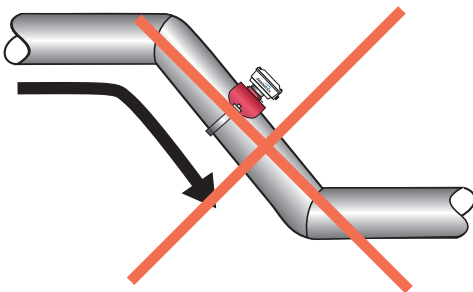

Air can be trapped

Better Installation

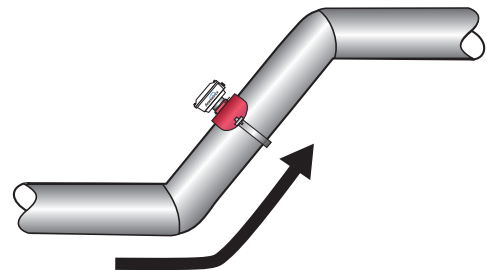

Allows air to bleed off



Caution: These flow sensors are not recommended for installation downstream of a boiler feedwater pump where installation fault may expose the flow sensor to boiler pressure and temperature. Maximum recommended temperature is 130 °F (Plastic), 200 °F (Metal).

FT430

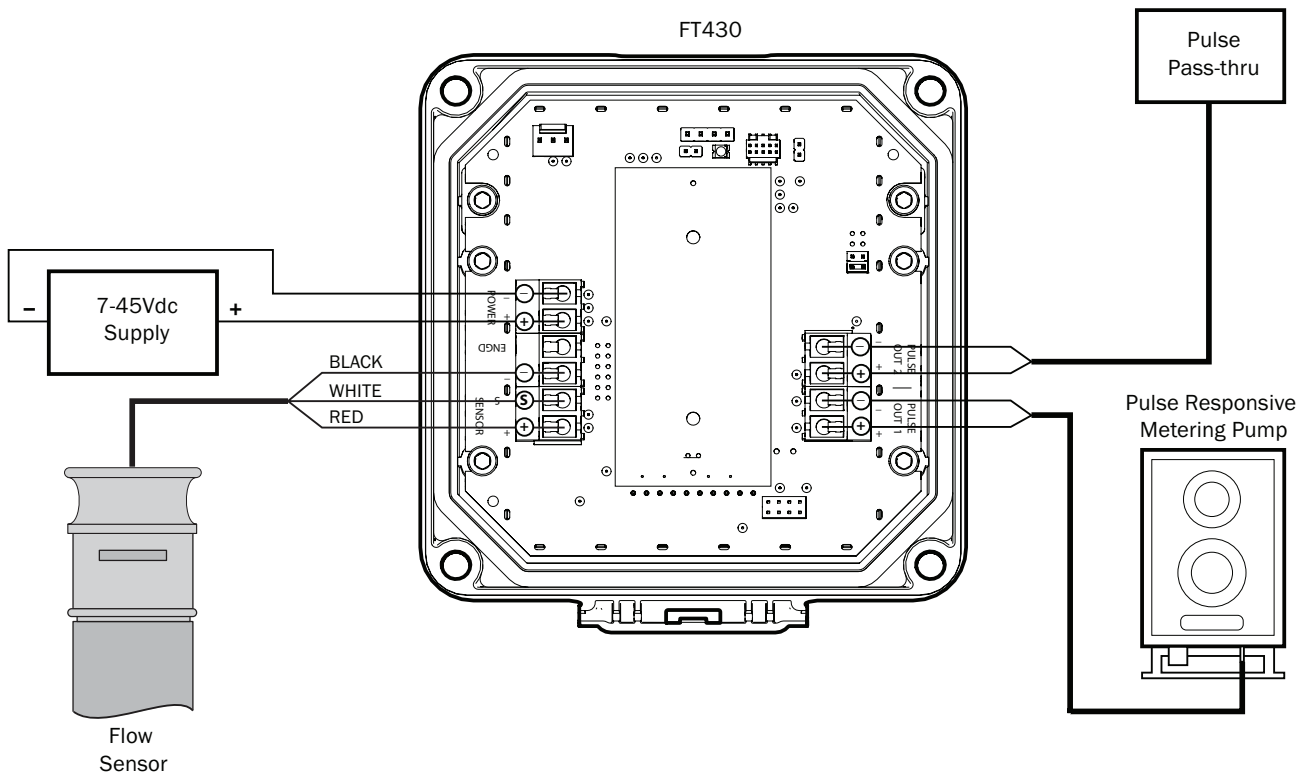

FT440

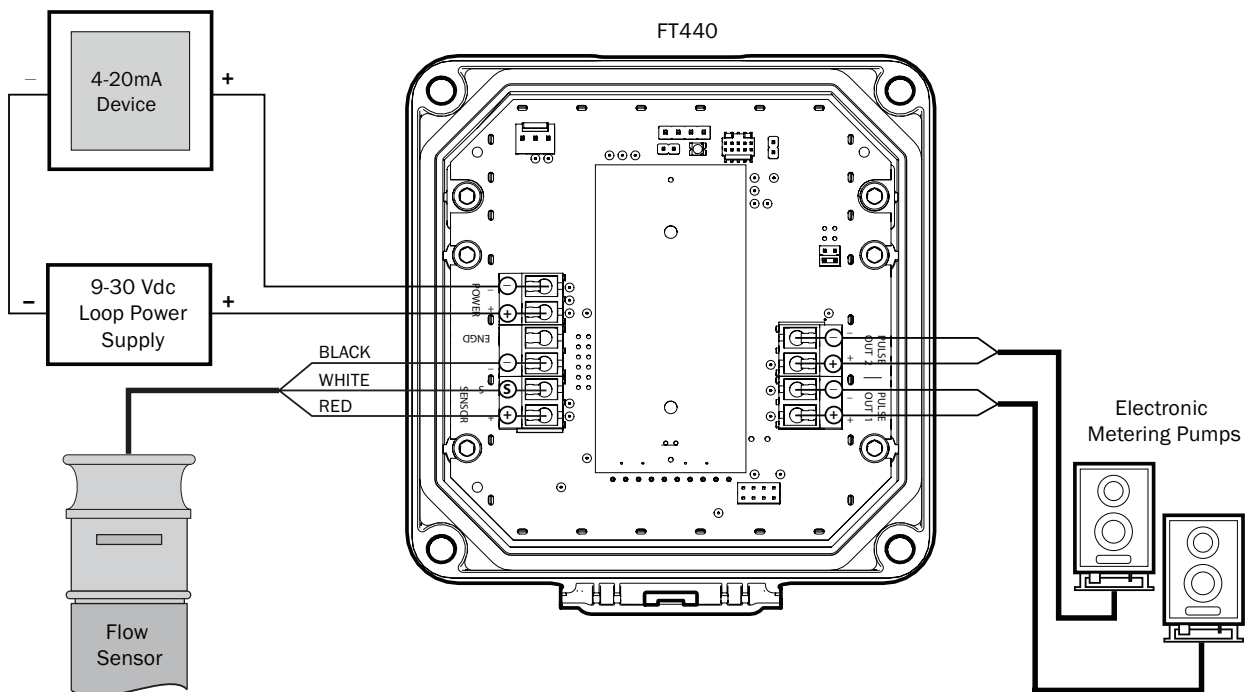

FT450

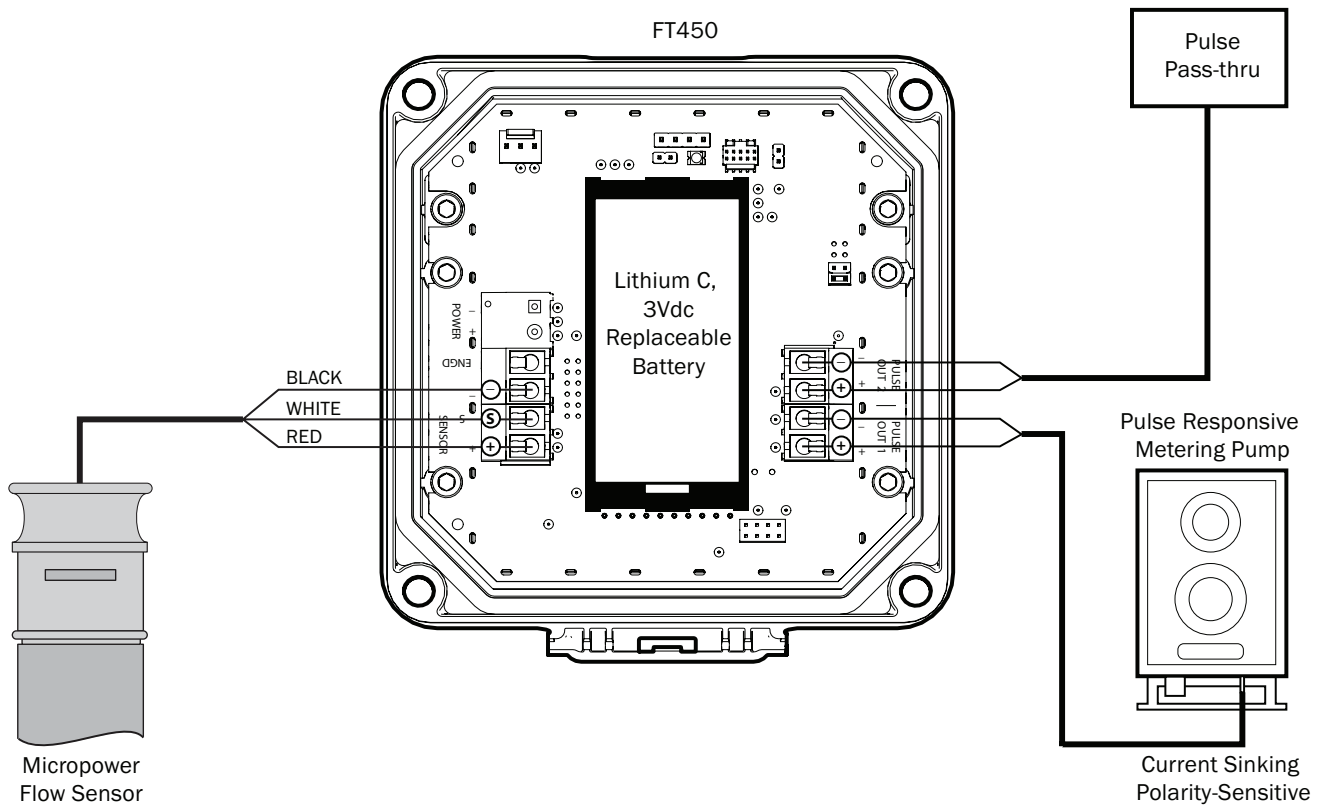

Connecting to PLC's and other non-Seametric Controls

Input Designed for Current Sinking (NPN) Devices

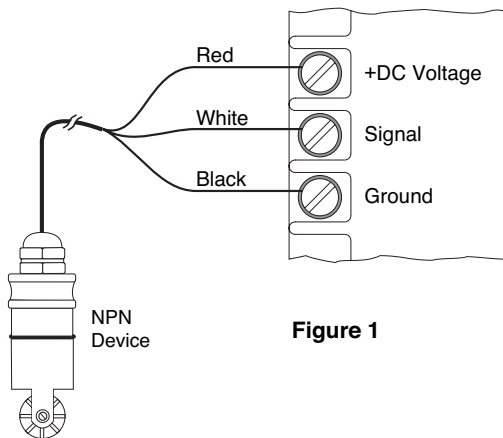

Input Designed for Current Sourcing (PNP) Devices

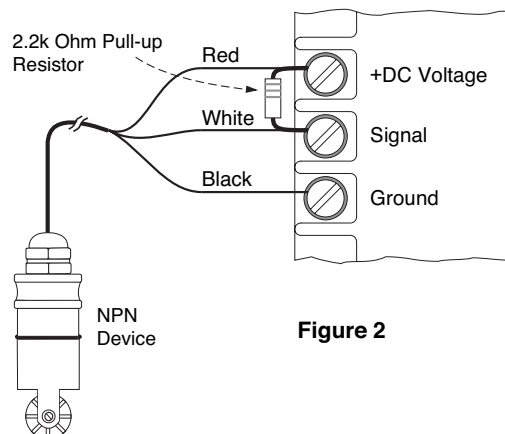

Modularity

Any of the TX800-Series flow sensors can have electronic modules mounted directly to them, either at the time of order or by adding an adaptor kit in the field (part number 102632). Alternatively, the flow sensor and indicator or transmitter can be installed remote from each other. The FT420 is an indicating transmitter (rate, total, 4-20 mA output), and the A055 is a blind 4-20 mA transmitter. For data logging, add the DL76. The FT520, which provides batching and other functions, is suitable for remote installation.

Output

The output is a current-sinking pulse (square wave) compatible with many controls in addition to the Seametrics indicators and transmitters. The most common of these are water treatment controllers and programmable logic controllers (PLC's). For these units, it is sometimes necessary to provide a pull-up resistor if the controller does not provide for a current-sinking output. (See the section on "Connecting to PLC's and other controllers" before connecting to a non-Seametrics control.)

Fittings

Since the TX800-Series sensors are not adjustable, they must be purchased with fittings appropriate to the application. The TX81x is sized for fittings of 1 1/2" to 3". The TX82x is for fittings of 4" and 8". Each fitting insures that the flow sensor is installed at the correct point. Every flow sensor and every tee fitting is wet calibrated. Saddle fittings are normally not wet calibrated, because they are field-installed on a pipe. In PVC however it is possible to order a saddle pre-installed on a standard length of pipe, in which case the entire assembly is wet-calibrated. For all other saddles, the K-factor (pulses per gallon) is established through testing with various standard schedules of pipe and provided with the saddle.

Minimum Flow

As with any other flow sensor, there is a rate below which the TX800-Series sensor cannot read. Check the flow rate table below for the minimum flow rate detectable by the sensor for a given pipe size.

Calibration ("K-factor")

The K-factor represents the actual number of pulses per gallon the meter produces during a flow test. This number can be entered into your electronic control to make it read properly. If the TX800-Series meter is ordered with a **tee fitting**, it is factory-calibrated in the fitting and the K-factor is indicated on the side of the fitting. For saddle and weldolet K-factors, see the **K-factor calculator** located at the bottom of the **www.seametrics.com** home page.

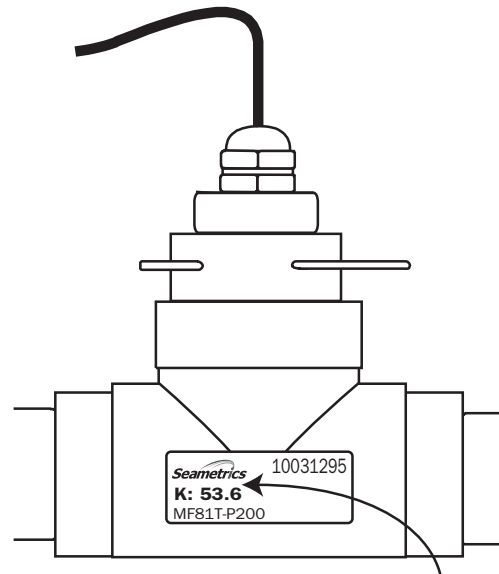

Find Your K-Factor Here

Flow Rate (Gallons per Minute)

	1½"	2"	3"	4"	6"	8"
Min	2.8	5	11.5	19.8	45	78
Max	190	314	691	1190	2700	4680

Flow Rate (Liters per Minute)

	1½"	2"	3"	4"	6"	8"
Min	10.60	18.93	43.53	74.95	170.34	295.26
Max	719.23	1189	2616	4505	10221	17716



Caution: Never remove the u-clip retainer when the pipe is under pressure. Always remove pressure from the pipe before attempting to remove the meter. Removal under pressure may result in damage or serious injury.

Rotor Replacement

It is unusual for a rotor to require replacement due to damage sustained in normal service. More commonly, the meter is dropped while it is out of the pipe. Another reason for rotor replacement is shaft wear after long service. Rotors are easily field-replaced.

To install a rotor, follow these steps:

1. Unscrew the threaded bearing housings to expose the shaft ends. If bearings are being replaced, back them completely out.
2. Remove the rotor. Put the new rotor in its place.
3. Thread in one bearing housing part way, then the other. Take care to start the end of the shaft into the bearing hole before tightening further.
4. Screw in bearing housings until they bottom

Note: Do not use excessive force.

5. Check for free spin. Blowing lightly on the rotor should result in it spinning rapidly and coasting to a smooth stop.

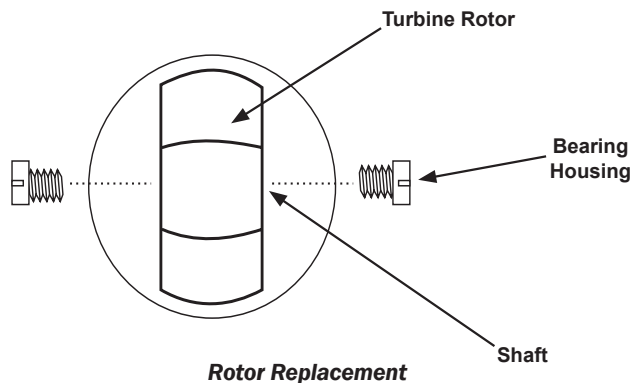

Signal Troubleshooting

The flow sensor has only one moving part, the rotor. If this is turning properly and there is no signal, the magnetic sensor is not operating properly. To check the signal, apply 12 Vdc regulated* power to the red (+) and black (-) leads. Set a multimeter to voltage reading. Put the positive multimeter lead on the red wire and the negative lead on the white wire. Slowly turn the rotor. Voltage reading should swing between +12 Volts and 0 Volts as the rotor turns. If it does not, the solid-state magnetic sensor is not working properly. Checking for continuity is not a useful test of these sensors.

***NOTE:** An unregulated power supply can exceed max voltage of micro powered sensor (gray cable) and damage sensor.

Sensor Replacement

It is very unusual for a sensor to require replacement in normal use. The primary cause of sensor failure is overvoltage (inadvertent connection of line voltage, for example) or incorrect polarity on hookup. The sensor is replaced by removing the strain relief, then threading out the sensor retainer plug. Remove the entire sensor capsule by pulling on the cable. The new sensor capsule can then be installed, orientation is not critical. Replace the retainer plug, and then replace and tighten the strain relief.

TX800 Series Parts List

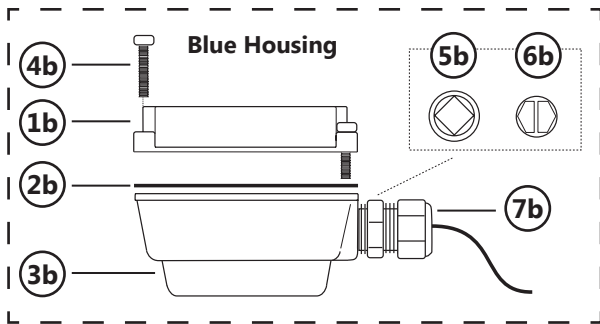
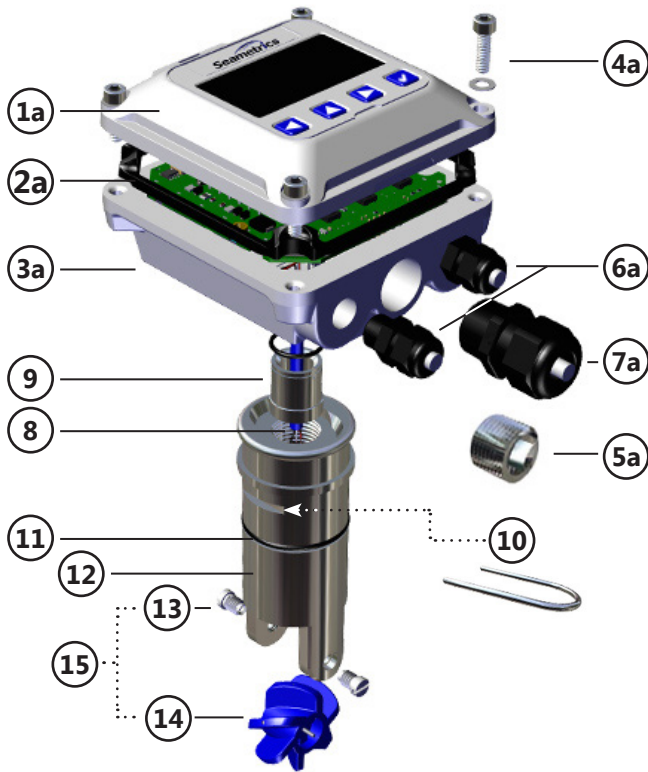

TX800 Series Parts		White Housing 1a thru 7a	Blue Housing 1b thru 7b
1	Upper housing/ electronics	Contact service representative for your specific model	Contact service representative for your specific model
2	Housing Gasket/Seal	102025	100411
3	Lower housing	Not field replaceable	Not field replaceable
4	Housing screw/washer kit (4 each)	100414	100414
5	Plug, steel (battery units)	100360	100360
6	Strain relief kit, small (includes 2)	100364	100364
7	Strain relief kit, large (includes 1) (externally powered units)	101850	101850
8	Sensor pickup	100508 (Micropower, green cable, FT450) 100419 (Standard, blue cable, FT430/440)	
9	Sensor retaining screw	100298	
10	U-clip, retainer	100154	
11	O-ring	100264 (EPDM) 100219 (Viton®)	
12	Body	See distributor	
13	Bearings (includes 2)	103315	
14	Rotor assembly	101862 (Kynar®/tungsten carbide)	
15	Rotor repair kit (#13 & #14 above)	101912 (Kynar®/tungsten carbide)	

Problem	Probable Cause	Try...
No signal after installation	<p>Insufficient flow</p> <p>Bad connections to control electronics</p> <p>Incompatible control</p> <p>Damaged or missing rotor</p> <p>Failed magnetic sensor</p>	<p>Reduce pipe size if possible, use different type of sensor</p> <p>Reconnect if necessary</p> <p>Use different power supply Add pull-up resistor (see page 9)</p> <p>Obtain new rotor and replace (see page 11)</p> <p>Replace magnetic sensor</p>
Inaccurate metering	<p>Not enough straight pipe between meter and severe flow disturbance</p> <p>Wrong K-Factor entered</p> <p>Magnetic sensor failing to pick up each blade</p>	<p>Move meter away from flow</p> <p>Check K-Factor (see page 10), enter correct K-Factor in your control</p> <p>Replace magnetic sensor and rotor</p>

