

FILL-RITE®

The Most Trusted Name in Pumps and Meters

IN THE THICK OF IT. FILL-RITE TN METERS.



RUGGED ACCURACY FOR DEPENDABLE INVENTORY CONTROL.

Fill-Rite TN Meters—15 models in all—provide the perfect solution when you need high pressure to transfer high-viscosity liquids quickly and safely. Incorporating positive-displacement nutating-disc technology, our TN Meters provide a high degree of accuracy in non-custody transfer applications such as inventory control of refined petroleum products and non-corrosive chemicals.

Fill-Rite TN Meters measure flows up to 60 gallons per minute, a viscosity range from 1 to 50,000 cSt, and they can handle temperatures from -15° F to +180° F.

High-pressure versions are available in two model sizes (TN740 and TN760 series) for use in automotive fluid distribution systems, lube trucks, and similar service.

Fill-Rite TN Meters are rugged and versatile, and just like our other Fill-Rite products, made

with the finest materials to ensure reliability and longevity. Fill-Rite—the best value—made right here in the USA.

Examples of Fill-Rite TN Meters

Contact your Fill-Rite customer service representative for a full list of models, or go to www.fillrite.com

Model TN740—1"

1,000 psi (69 bar) for heavy fuel oils, hydraulic oils, and lubricating oils.

Model TN760—1½"

400 psi (28 bar) for heavy fuel oils, hydraulic oils, and lubricating oils.

Model TN860—1½"

150 psi (10 bar) for ALS, biodiesel, diesel, fuel oil No. 2, and kerosene. May also be used to measure non-potable water.

FLOW & PRESSURE CAPABILITIES

Item number	at 1 cST		at 5,000 cST		Pressure (psi)	Pressure (bar)	Size	Threads	Calibration	Seals	Applications	Viscosity
	Flow (GPM)	Flow (LPM)	Flow (GPM)	Flow (LPM)								
TN740AN1CAA1TAI	10	38	4	15.2	1,000	69	1"	NPT	1/10 Gallon	Fluorocarbon	High Viscosity Lubricating Oils	125 + cSt
TN740AN1CAA1LAI	10	38	4	15.2	1,000	69	1"	NPT	Liter	Fluorocarbon	High Viscosity Lubricating Oils	125 + cSt
TN740AN1CBA1LAI	10	38	4	15.2	1,000	69	1"	BSPT	Liter	Fluorocarbon	High Viscosity Lubricating Oils	125 + cSt
TN760AN1CAB1GAF	15	57	6	22.8	400	28	1.5"	NPT	Gallon	Fluorocarbon	High Viscosity Lubricating Oils	125 + cSt
TN760AN1CAB1LAF	15	57	6	22.8	400	28	1.5"	NPT	Liter	Fluorocarbon	High Viscosity Lubricating Oils	125 + cSt
TN760AN1CBB1LAF	15	57	6	22.8	400	28	1.5"	BSPT	Liter	Fluorocarbon	High Viscosity Lubricating Oils	125 + cSt
TN860AN1CAB2GAC	60	228	N/A	N/A	150	10	1.5"	NPT	Gallon	Fluorocarbon	Non-Potable Water	1 – 2 cSt
TN860AN1CAB2LAC	60	228	N/A	N/A	150	10	1.5"	NPT	Liter	Fluorocarbon	Non-Potable Water	1 – 2 cSt
TN860AN1CBB2LAC	60	228	N/A	N/A	150	10	1.5"	BSPT	Liter	Fluorocarbon	Non-Potable Water	1 – 2 cSt
TN860AN1CAB1GAC	55	209	N/A	N/A	150	10	1.5"	NPT	Gallon	Fluorocarbon	Diesel, Biodiesel, Fuel Oil #2, Kerosine, Jet Fuel	3 – 22 cSt
TN860AN1CAB1LAC	55	209	N/A	N/A	150	10	1.5"	NPT	Liter	Fluorocarbon	Diesel, Biodiesel, Fuel Oil #2, Kerosine, Jet Fuel	3 – 22 cSt
TN860AN1CBB1LAC	55	209	N/A	N/A	150	10	1.5"	BSPT	Liter	Fluorocarbon	Diesel, Biodiesel, Fuel Oil #2, Kerosine, Jet Fuel	3 – 22 cSt
TN860AN1CAB2GBC	60	228	N/A	N/A	150	10	1.5"	NPT	Gallon	PTFE	Airline Lavatory Service, Solvents	1 – 2 cSt
TN860AN1CAB2LBC	60	228	N/A	N/A	150	10	1.5"	NPT	Liter	PTFE	Airline Lavatory Service, Solvents	1 – 2 cSt
TN860AN1CBB2LBC	60	228	N/A	N/A	150	10	1.5"	BSPT	Liter	PTFE	Airline Lavatory Service, Solvents	1 – 2 cSt

STANDARD FEATURES

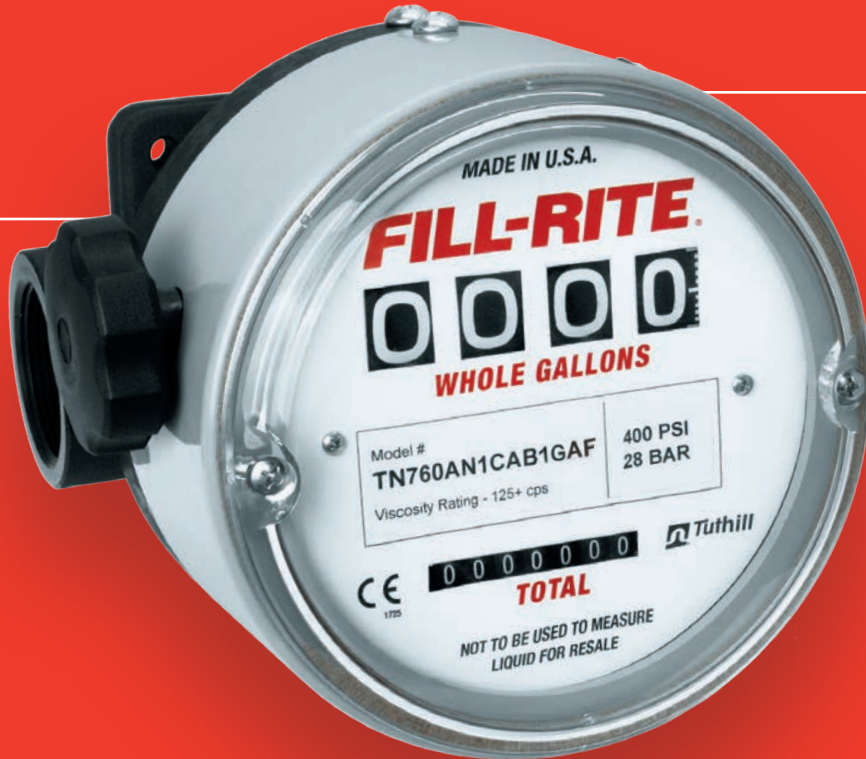

- .5 to 60 gpm (230 lpm) — based on viscosity and temperature for your needs
- PTFE or fluorocarbon seals
- Durable anodized aluminum case with polyphenylene sulfide resin (Ryton) chamber
- Dependable nutating-disc technology
- $\pm 2\%$ accuracy over a 10:1 turndown
- $\pm 0.25\%$ repeatability
- Four-wheel display with 11/16" digits
- Totalizer display to 999,999 units
- Displays options in 1/10 gallon or whole gallon or liter
- Available with NPT or BSP ports
- Ambient temperature:
-15° F to +180° F (-26° C to +80° C)

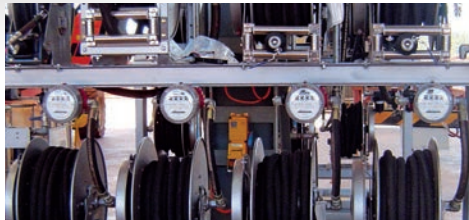

TN METER MEASUREMENTS

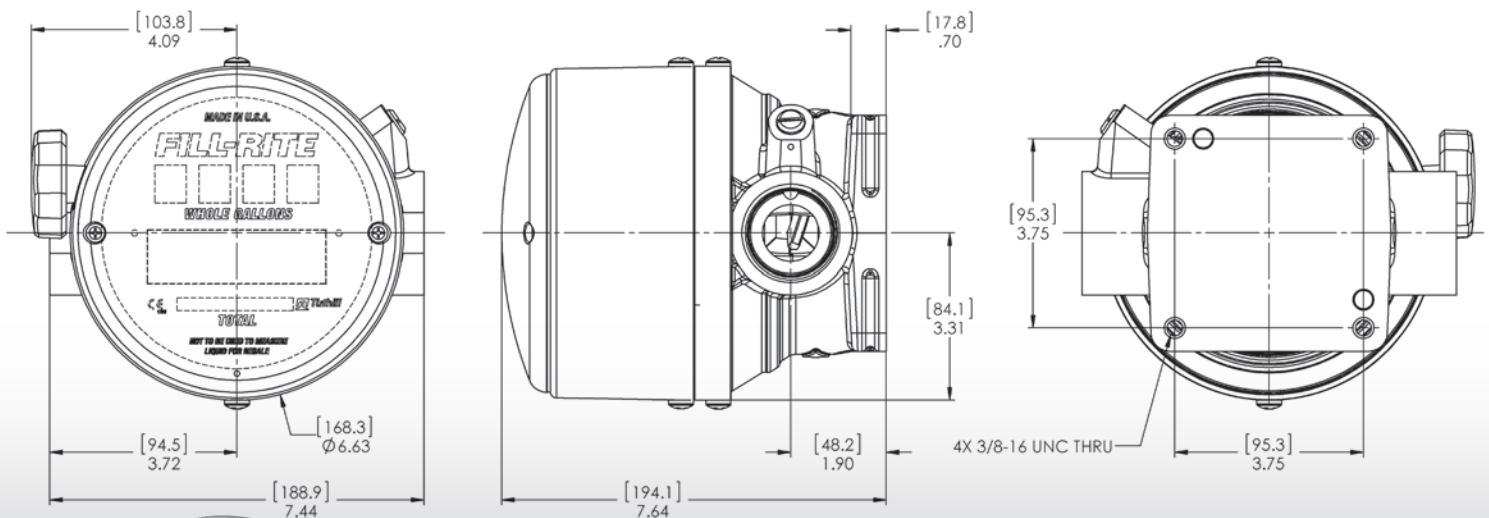



VISCOSITY CAPABILITY

- TN860AN1C_B1_AC, calibrated for water (1-2 cSt = 32-35 SSU), with fluorocarbon seals.
- TN860AN1C_B1_BC, calibrated for alcohols, solvents, and ALS (1-2 cSt = 32-35 SSU), with PTFE/perfluoroelastomer seals.
- TN860AN1C_B2_AC, calibrated for low-viscosity refined fuels (3-22 cSt = 35-100 SSU), with fluorocarbon seals.
- TN760AN1C_B1_AF, calibrated for high-viscosity lube and hydraulic oils (125+ cSt = 600+ SSU), with fluorocarbon seals.
- TN740AN1C_A1_AI, calibrated for high-viscosity lube and hydraulic oils (125+ cSt = 600+ SSU), with fluorocarbon seals.

Flow meter error when used outside of intended calibration range.

		TN860 OPERATING RANGE				ACTUAL LIQUID VISCOSITY						TN740 AND TN760 OPERATING RANGE					
		SSU	50	100	150	200	250	300	350	400	450	500	600	700	800	900	1,000+
		cSt	7	22	32	42	52	63	74	85	95	105	125	150	170	195	220+
TN740	GAL.	-20.5%	-16.9%	-14.5%	-8.4%	-7.2%	-4.8%	-3.6%	-2.4%	-2.4%	-1.2%	-1.2%	-1.2%	-1.2%	0.0%	0.0%	0.0%
	LITER	-20.4%	-16.2%	-14.6%	-8.6%	-6.7%	-4.8%	-3.5%	-2.9%	-2.2%	-1.6%	-1.3%	-1.0%	-0.6%	-0.3%	-0.3%	0.0%
TN760	GAL.	-20.5%	-16.9%	-14.5%	-8.4%	-7.2%	-4.8%	-3.6%	-2.4%	-2.4%	-1.2%	-1.2%	-1.2%	-1.2%	0.0%	0.0%	0.0%
	LITER	-20.4%	-16.2%	-14.6%	-8.6%	-6.7%	-4.8%	-3.5%	-2.9%	-2.2%	-1.6%	-1.3%	-1.0%	-0.6%	-0.3%	-0.3%	0.0%
TN860	GAL.	-3.1%	0.0%	2.1%	7.2%	8.2%	10.3%	11.3%	12.4%	12.4%	13.4%	13.4%	13.4%	13.4%	14.4%	14.4%	14.4%
	LITER	-3.6%	0.0%	1.4%	6.6%	8.2%	9.9%	11.0%	11.5%	12.1%	12.6%	12.9%	13.2%	13.4%	13.7%	13.7%	14.0%
TN860	GAL.	0.0%	3.0%	5.0%	10.0%	11.0%	13.0%	14.0%	15.0%	15.0%	16.0%	16.0%	16.0%	16.0%	17.0%	17.0%	17.0%
	LITER	0.0%	3.4%	4.8%	9.8%	11.4%	13.0%	14.0%	14.6%	15.1%	15.6%	15.9%	16.1%	16.4%	16.7%	16.7%	16.9%

Bypass calibrator can correct for most of the error within this range.



Made in

 USA

WWW.FILLRITE.COM

 **Tuthill**

8825 Aviation Drive | Fort Wayne, Indiana 46809
 P (260) 747-7524 F (260) 747-3159