

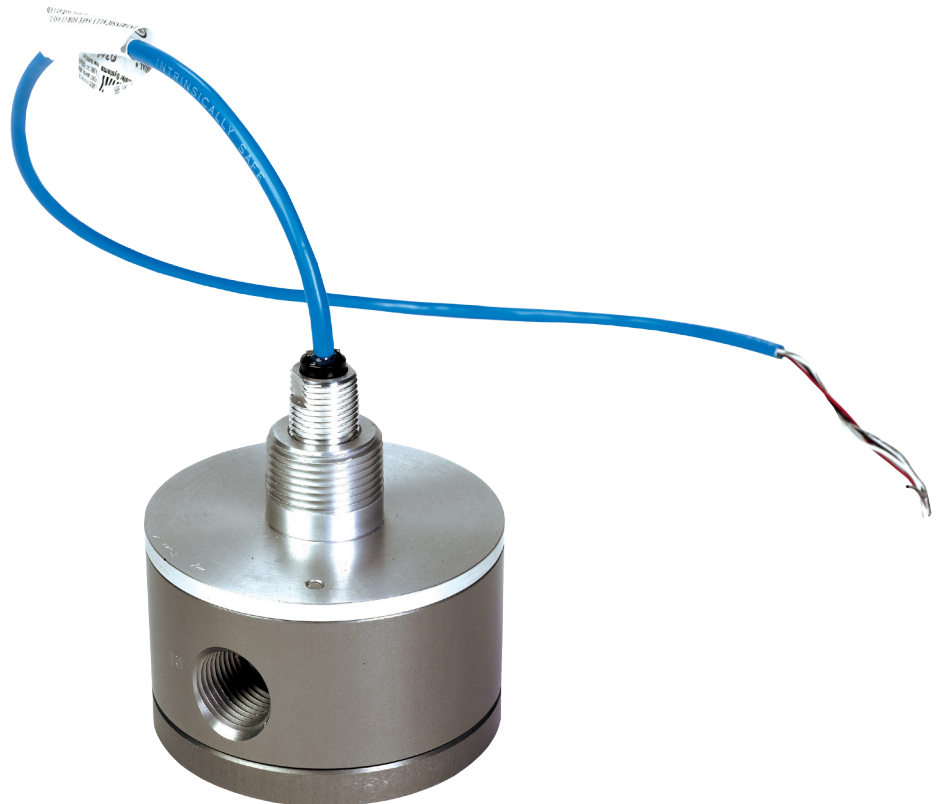

PRECISION METER

Installation, Operation, and Parts Manual

TM Series
Electronic





P (800) 634-2695 • (260) 747-7524

F (800) 866-4861

8825 Aviation Drive
Fort Wayne, Indiana 46809

Our manufacturing facility is
ISO 9001:2008 and Atex Certified



Manufacturing Facility located in Fort Wayne, IN

About Tuthill Precision Meters.....	1.3
Principle of Operation.....	1.3
Fluid Compatibility.....	1.3
Meter Specifications and Model Capacity.....	1.4
Safety Instructions.....	1.5
Installation and System Recommendations.....	1.5
Start-Up Procedure.....	1.6
Flow Meter Calibration and Re-calibration.....	1.6
Trouble Shooting the Flow Meter.....	1.7
Trouble Shooting and Replacing the Sensor: Hall Effect	1.8
Reed Switch.....	1.9
Quadrature.....	1.10
Wiring Diagrams:	
CC56 & CC56/PIA-300	1.11
PIA-300 and Fuel Sentry Systems	1.12
PC58/PCDT58 and PC58/PCDT58 with 4.20mA.....	1.13
ELNC & ELNC/Backlight and Pulse	1.14
EL2057/ELNC	1.15
SCL/EMR ³ Register	1.10
Control Drawing for Pulsers	1.16
Parts List:	
Model TM02D	2.1
Models TM03A and TM03D	2.2
Models TM04 A and TM04D	2.3
Models TM06A and TM06D	2.4
Specifications for PIA-300 (optional Signal Conditioner)	3.1
Application Check List for Future Applications	3.3

Tuthill Corporation's humble beginnings date back to 1892, when James B. Tuthill purchased a clay quarry and a kiln and began supplying Chicago common bricks to local construction firms. In the early 1920's, his efforts to improve lifting clay from the quarry turned up a new transportation idea—a steam-powered truck engine.

The design eventually proved unworkable, but Tuthill recognized the value of the engine's small, internal gear pump, which injected fuel oil directly into the truck boiler. The pump design was refined and was marketed to companies that produced oil-fired boilers for use in residential and industrial heating, where it enjoyed great success and formed the basis on which the Tuthill Pump Company was formed.

Over 120 years and five generations later, Tuthill Corporation is a global presence in vacuum pumps, blowers, plastics, and fuel and chemical transfer systems. We take great pride in our "Made in USA" moniker, making quality and durability top priorities. Tuthill Precision Meters carry that legacy and competency in fluid transfer products to new levels. Our patented "Wave Form" gears provide extreme accuracy through strict control of fluid slippage in the metering chamber, and our electronics work with virtually any metering or management system.

Your choice of a Tuthill Precision Meter is an investment in professional equipment that will pay dividends for years to come. We appreciate your business, and look forward to serving you in the future!

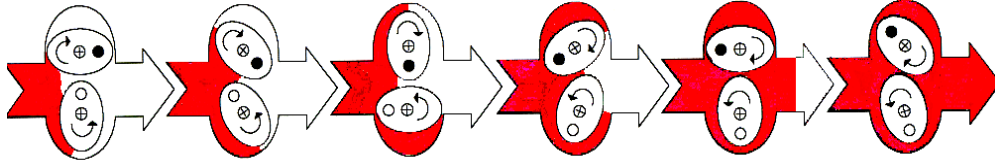

- Only 2 moving parts.
- Patented 'Waveform' oval gears = sustained accuracy with a minimum of maintenance.
- No metal-to-metal contact in measuring chamber or in bearings.
- The lowest differential pressure values amongst rotary PD meters.

=> Lower Cost of Ownership!

About Tuthill Precision Meters

We thank you for purchasing a Tuthill product for liquid measurement service. Formerly known as Fluid Power Products, it is now a trade name of Tuthill Precision Meters. FPP was established in 1980. Since its inception, the company has been dedicated to manufacturing cost-effective, high performance flow metering devices for petroleum, industrial, commercial and municipal service.

Our facilities include computerized order entry and inventory control, so that you are assured of accurate and prompt deliveries. Furthermore, our production personnel ensure that each order, regardless of size, receives individual attention.

Constant attention to new product development and production design, our high standards of manufacture and final testing are the reasons why Tuthill Precision Meters meet your most demanding requirements. With the 'Waveform' oval gear (2003 patent) meter accuracy is better than ever before.

Our meters are used in batching, blending, process control and to dispense fluids in liquid handling facilities throughout the World. Service includes gasohol blends, bio-diesel and special formulation racing fuels.

Principle of Operation

Positive Displacement meters have a measuring chamber, where inlet & outlet are separated by rotors, a rotating element or sliding vanes. As the liquid passes through the flow meter, it causes the rotors/element/vanes to turn, which forms the basis for volumetric measurement.

The **Oval Gear** metering principle is based on two elliptical (oval) gears, which turn on center on two horizontal shafts inside a measuring chamber formed by two overlapping cylinders. The oval gears have meshing teeth along their entire circumference, ensuring that the gears will maintain correct position in relation to each other at all times, without the use of timing gears.

The volume being transferred from the inlet to the outlet side (= volume measured), forms between the oval gear and the side of the measuring chamber, alternately in the upper and the lower half of the measuring chamber. In a full 360° rotation of the gears, four such known volumes are released to the downstream side of the flow meter.

The flow meter is 100% gland-less with static O-ring seals

only. Internal magnets are detected by a sensor (pulser) mounted in flow meter case. The pulser generates an electrical on/off signal, which can be used to drive a signal conditioner or an electronic register.

With precision machining and close internal tolerances, the slippage is minimal for superior linearity (accuracy) over a broad turn-down ratio. Oval gear meters are largely unaffected by changes in liquid viscosity. In TM Series meters we expect a shift of no more than 2-4% due to variations in liquid viscosity between 1 and 100 cSt. As the viscosity increases further, there is no noticeable change.

To ensure optimum linearity (accuracy), TM Series meters should be field calibrated correct for individual meter variations, liquid viscosity and local system/operational factors.

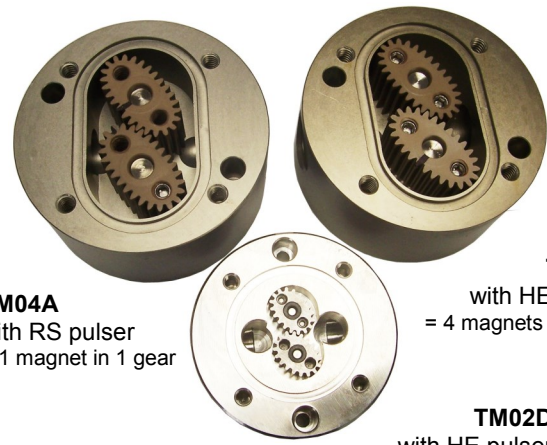

TM04A
with RS pulser
= 1 magnet in 1 gear

TM04A
with HE pulser
= 4 magnets in gears

TM02D
with HE pulser
= 2 magnets in 1 gear

Fluid Compatibility

Tuthill flow meters are available in anodized aluminum and stainless steel, with a variety of rotor types and seals, to ensure compatibility with a broad range of liquids. If in doubt about compatibility with a specific fluid, please refer to **Tuthill Precision Meter Technical Manual**. If that publication does not provide a clear answer, please consult with your authorized Tuthill Meter distributor, or Customer Care at the factory.

While most refined petroleum products can be handled with the same flow meter, some require different rotors and/or seals. *Do not change service liquid, without consulting with your authorized FPP Meter distributor.*



TM Series, Specifications & Capacity

Materials:

TM●●A Case & cover : Anodized aluminum
 Posts (shafts) : 316SS
 Seal : Viton™ std., Teflon™ optional

TM●●C Case & cover* : 303SS
 Posts (shafts) : 316SS
 Seal : Teflon™ standard

TM●●D Case & cover* : 316SS
 Posts (shafts) : 316SS
 Seal : Teflon™ standard

Rotors (oval gears) : **TM02** SS/Teflon bearings
TM03 PPS standard, SS/Teflon bearings opt.
TM04 PPS standard
TM06 PPS standard

* Pulser retainer (exterior non-wetted fitting) is anodized aluminum.

Pressure Rating:

TM Series meters are manufactured with 2 different pressure ratings (though not in all sizes/materials). Pressure rating is identified in position 11 in the Part Number:

Pos. 11 in P/No.	K	L	F <i>obsolete 2009</i>
	1500 PSI 103 BAR	2500 PSI 173 BAR	400 PSI 28 BAR
MODEL			
TM02D	✓		
TM03A	✓		
TM03D	✓		
TM04A	✓		
TM04C		✓	
TM04D	✓		
TM06A	✓		
TM06C	✓	✓	
TM06D	✓		

Pressure rating applies to -40°F/+100°F (-40°C/+38°C) temperature range. *At higher operating temperatures the pressure rating is reduced by factors shown below:*

Temperature Rating:

	-40°F/+100°F	150°F	200°F	225°F	250°F	275°F	300°F
	-40°C/+100°C	66°C	93°C	107°C	121°C	135°C	150°C
A.A.	1.00	0.89	0.79	0.75	0.72	0.62	0.43
S.S.	1.00	0.91	0.83	0.79	0.74	0.70	0.67

TM Series meters are rated for use on liquids with temperature in -40°F/+300°F (-40°C/+150°C) range. This temperature rating applies to the flow meter only.

Electronic signal conditioner, totalizer or register attached to the flow meter will have a different rating, which may differ at both the low and high end of the range (refer to manual for electronic components). When that is the case, the electronic component must be installed remote from the flow meter.

Flow Meter Nominal Capacity:

TM02D	0.3 GPM	1.1 lpm
TM03	3.0 GPM	11 lpm
TM04	10 GPM	38 lpm
TM06	20 GPM	76 lpm

On liquids with 1 cSt viscosity.

Actual capacity depends upon liquid lubricity, viscosity and operating temperature. Normal turn-down is 10:1 from nominal (maximum) value shown. Optimum performance is between 50% and 85% of nominal capacity.

When the viscosity exceeds 200 cSt, maximum flow rate is restricted, but the flow meter will have satisfactory linearity (accuracy) down to 2-3% of nominal capacity.

To determine model maximum capacity on higher viscosity liquids, find the **flow meter coefficient** for maximum liquid viscosity in table below, and multiply nominal capacity with this factor.

Flow Meter Coefficient				
Liquid Viscosity	Rotor Code		Liquid Viscosity	
	A	E & K		
1 cSt	1.000	1.000	32 SSU	
10	1.000	1.000	60	
50	1.000	1.000	240	
100	1.000	1.000	475	
200	1.000	1.000	925	
300	0.855	0.855	1,425	
400	0.770	0.770	1,875	
500	0.710	0.710	2,350	
600	0.660	0.660	2,825	
700	0.625	0.625	3,300	
800	0.595	0.595	3,775	
900	0.560	0.560	4,250	
1,000	0.540	0.540	4,725	
2,000	0.350	0.350	9,450	
3,000	0.275	0.275	14,150	
4,000	0.240	0.240	18,875	
5,000	0.190	0.190	23,600	
6,000	0.160	0.160	28,325	
7,000	0.135	0.135	33,050	
8,000	0.115	0.115	37,750	
9,000	0.100	0.100	42,475	
10,000		0.085	47,200	
20,000		0.072	94,400	
30,000		0.061	141,600	
40,000		0.052	188,800	
50,000		0.044	236,000	
60,000		0.037	283,200	
70,000		0.031	330,400	
80,000		0.026	377,600	
90,000		0.022	424,800	
100,000		0.019	472,000	

SAFETY INSTRUCTIONS

Make sure that all necessary safety precautions have been taken, including proper clothing, personal safety equipment and fire safety equipment if required.

Before Start-Up of the Flow Meter, **make certain** that:

1. The meter is properly mounted, secured and piped.
2. All connections are tight.
3. All bleed and drain valves are closed.
4. Do NOT smoke near meter, or use meter near an open flame, when metering flammable liquids. Fire or Explosion could result.
5. This meter is not intended for use on liquids, which require 3A Sanitary equipment for human consumption. It may be used on edible liquids, which do not spoil easily, such as vegetable oils, liquid sweeteners & similar.

Install the Flow Meter and Accessories in compliance with all applicable Local, State & Federal Construction, Electrical and Safety Codes.

Installation

- Positive Displacement meters are designed to operate full of liquid. The meter should be installed in a manner, so that it **remains full of liquid at all times**.

The flow meter is not designed to operate on air, but the design and materials of construction allow for operation on vapor *for short periods of time* without damage to the oval gears or flow meter internals.

- **Hydraulic shock** can be harmful to flow meter and other system components. Consideration to eliminate hydraulic shock should be given in selection of pump and design of the piping system.
- The flow meter can operate with liquid going Left-to-Right, Right-to-Left or Vertical Up, but it must be installed with **rotor shafts in horizontal position** (= with vertical end covers). Failure to observe this will impact negatively on flow meter accuracy.



- Protective caps installed in flow meter flanges prior to shipment should remain in place until you are ready to install in the piping system.
- It is recommended that a **Strainer** be installed upstream of each flow meter, to prevent damage from foreign matter, such as welding slag, pipe scale or parts breaking off other equipment.
- Allow adequate space for removal of strainer basket cover, so strainer basket can be cleaned.

OPERATING TEMPERATURE

TM Series meters are rated for operation from **-40°F/+300°F (-40°C/+150°C)**. However:

- They are **not suitable for cryogenic service**.
- When temperature exceeds **+120°F (+50°C)**, 'K' rotors must be used, and pressure rating is reduced. Refer to FPP Technical Manual for details.

OPERATING PRESSURE

TM Series meters Maximum **non-shock** Operating Pressure is (see position 11 in the P/No.):

Code F 400 PSI (= 10.3 BAR) at 100°F

Code K 1500 PSI (= 103 BAR) (+38°C).

Code L 2500 PSI (= 175 BAR)

The flow meter should never be operated in excess of this pressure. Care should be taken to eliminate thermal and hydraulic shock conditions, so that system pressure never exceeds the flow meter's Maximum Working Pressure rating.

- Flush the system to remove all debris, scale and welding slag **prior to flow meter installation**. If this is not possible, temporarily remove rotors (oval gears), and reinstall after the system has been flushed.
- Apply pipe compound to male threads. **Do NOT use Teflon tape**.
- Avoid pipe stress when installing the flow meter.
- When installing the flow meter, consider future maintenance of both flow meter and accessories. The meter can be serviced in place, provided block (isolation) valves are included, and adequate space allowed.
- In critical installations a **by-pass line is recommended**, so flow can continue while flow meter is being serviced.
- **Thermal relief valves are recommended**, and should be installed whenever it is possible to block (isolate) the flow meter between two valves. The pressure rise in a closed system, from just a few degrees increase in temperature, can be many times normal working pressure.
- **Connections for calibration** should be provided during installation. An easy means for diverting flow into a calibration vessel (or through a Master Meter) should be considered.

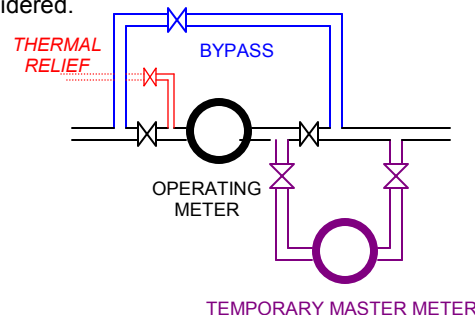

Start-Up & Operation

Very slowly fill the system with liquid, to avoid operating the flow meter on air or vapor. This can be accomplished in the following manner:

1. Throttle the meter inlet valve, and allow the system to fill slowly by gravity.
2. Crack open the outlet valve. Start the pump, and then slowly crack open the inlet valve, filling the meter slowly before fully opening the inlet and outlet valves.

In normal operations:

- Avoid sudden changes in temperature.
- Avoid sudden changes in flow rate.
- Gradually increase or decrease the flow rate.

Flow Meter Calibration

It is recommended that written records be maintained on all flow meters. These records should include:

- Supplier and Service Department phone number.
- Date of installation.
- Details of maintenance performed.
- Flow meter initial K Factor (number of pulses per unit of volume).
- Date & result of each re-calibration, with changes in flow meter K Factor.

TM Series flow meters are given a functional 'Pass or Fail' test prior to shipment, but written records of this test are not maintained. The nominal K Factor shown on flow meter cover is an average value, which should be used as a starting point when field calibrating on actual liquid of operation.

Nominal K Factor on 1 cP liquid

These values are subject to individual flow meter variation, as well as expected fluctuation due to liquid viscosity (see above).

	HE pulser		RS pulser	
TM02	7700 PPG	2035 ppl	3750 PPG	1017 ppl
TM03	2800 PPG	740 ppl	700 PPG	185 ppl
TM04	805 PPG	213 ppl	201 PPG	53 ppl
TM06	405 PPG	107 ppl	101 PPG	27 ppl

Accuracy curves of individual flow meters vary some. Also, the accuracy curve of all flow meters will shift due to variations in liquid viscosity; perhaps as much as 3-4% from 1 cSt to 100 cSt. The accuracy curve will not shift significantly at higher viscosities, even if the actual operating liquid has viscosities up to 500,000 cSt.

Since we cannot test on actual fluid of operation, it is the responsibility of the buyer to field calibrate in place of service on actual operating liquid.

Frequency

TM Series meters are not intended for use in Custody Transfer service, so Weights&Measures regulations should not apply. If local authorities issue regulations for non-W&M flow meters, such regulations must be observed.

If user is ISO9000 certified, user ISO standards will indicate frequency of re-calibration for instrumentation. Those rules should be observed. If no regulations or standards apply, our recommendations are:

- A. Calibrate immediately after installation.
- B. Re-calibrate after 15-30 days.
- C. Re-calibrate after 180 days and again after 360 days.

After the run-in calibration (B) and follow-up calibrations (C), it is possible to evaluate degree of change under normal operating conditions. Based on values found, and total volume being metered under normal operating conditions, decide whether a 6, 12 or possibly 24 month schedule should be adopted.

Procedures & Methods

Flow meters used in systems where the flow rate can fluctuate, should be tested at minimum, intermediate & maximum flow rates. In non-W&M service, a flow meter always operating at a steady flow rate, can be tested at that flow only.

All tests should be repeated 3 times to confirm repeatability. All tests should be of at least 60 second duration, to minimize effect of flow meter error during start-up & shut-down.

- After calibrating a known volume (X) into an accurate prover, or through a master meter, compare with register reading (Y) and calculate correction:

$$\frac{X - Y}{X} \times 100 = \% \text{ correction}$$

- When re-calibration has established that a correction is required, change flow meter K Factor:
 - When prover/master meter reading is **less than flow meter register reading**, add percentage calculated to the original K Factor..
 - When prover/master meter reading is **more than flow meter register reading**, subtract percentage calculated from the original K Factor.
- Circulate product through the flow meter for a few minutes. Then perform at least 3 more tests, to confirm flow meter accuracy & repeatability.
 - If the flow meter does not repeat, it will likely require a new set of rotors (oval gears).
Before ordering new gears, inspect the measuring chamber for scratches or wear. If the measuring chamber is scratched or scored beyond what can be smoothed with emery paper, the flow meter should be replaced.
- Finally, enter date and % correction on the permanent flow meter record.

Prior to opening or disassembly of any flow meter, all internal pressure must be relieved and all liquid must be drained. This must be done in accordance with applicable company and local codes & ordinances.

Make sure that all necessary safety precautions have been taken, including proper clothing, personal safety equipment and fire safety equipment if required.

No Flow

- Blocked strainer basket. Clean the basket.
- Faulty or non-functioning pump. Repair pump.
- Valve stuck in closed position. Check and repair valves.
- Flow meter 'frozen' due to build-up of chemical salts (or frozen water) inside the measuring chamber. Clean the flow meter (see page 1.8), and inspect for damage.
- Meter jammed on a particle that has passed through a damaged strainer basket. Remove particle and replace rotors if necessary, replace strainer basket.

Reduced Flow Rate

- Strainer basket partially blocked. Clean the basket.
- Pump not functioning correctly. Repair pump.
- Valve stuck in partially closed position. Check valves and repair.
- Meter rotors (oval gears) partially 'salted' with chemical deposits, slowing the movement. Clean the meter (see page).

Product Flows, but the register does not record

- Check power supply to the register.
- Check the connection between the pulser and the electronic register.
- Check pulser output (see page 1.8). Replace if needed.
- If product is flowing, and the flow meter is generating a pulse signal, the problem is in the electronic register. Please refer to the manual for the electronic register.

Product Flows, register does not record correctly

If **error factor is constant**, the flow meter is fine. The likely cause is either:

- Incorrect K Factor in the electronic register. Re-calibrate the meter and correct the K Factor.
- A constant problem with air getting into the system. Review system design and control valves.

If the **error is random**, the likely cause is either:

- Poor cable connections (insulation not trimmed, or stray strands getting close to incorrect contacts). This can be signal conditioner (if included) or where pulse signal is connected to the register. Inspect and correct connections as necessary.
- Valve leaking, allowing a portion of the system to drain. Check & repair valves.
- An intermittent problem with air in the system, combined with inadequate air elimination. Review system design and control valves.
- Interference from other electrical equipment nearby, possibly combined with sub-standard cables.

Breaking Teeth on Rotors (Oval Gears)

This is a sign of hydraulic shock conditions in the system. Common sources:

- Starting or stopping flow too rapidly. Replace damaged components and **correct operational practices**.
- Pump by-pass not adjusted properly. Re-adjust as necessary.

Leakage from Cover

The seals (and possibly end covers) have been damaged due to excessive pressure. There are two possible sources:

- Starting or stopping flow too rapidly. Replace damaged components and **correct operational practices**.
- The flow meter is in a system, where it can be isolated between two valves. Add a Thermal Relief Valve to bleed off excess pressure when the temperature rises.

Installation, Maintenance & Service must be performed by personnel:

A. Qualified to work on this type of equipment.

B. Familiar with all applicable local codes and ordinances covering the type of service, where the flow meter is used (gasoline, LPG, etc.).

Avoid pipe strain and stress when making flow meter repairs. The weight of the pipe and the flow meter must be supported independently. This allows the flow meter to be serviced without affecting the alignment of piping.

Avoid prying or exerting heavy pressure on precision parts, as this can affect the performance of the flow meter. Assure that all machined parts are free of burrs and nicks. Stone all machined surfaces if necessary to remove burrs.

Always coat bolt threads with an anti-seize or an appropriate lubricant. This prevents thread damage, and assures that proper torque values are applied during re-assembly. If threads are damaged, repair using inserts.

**Relieve All Internal Pressure Prior to Opening
Drain Liquid prior to Working on Flow Meter**

**Rinse with Neutral Liquid
prior to Seasonal Storage**

**Triple Rinse with Neutral Liquid
prior to Shipment for any reason.**

Intrinsically Safe rated sensors for

Cl. 1, Div. 1, Grp. D and Zone 0 applications

CD1002, UL 9HA6, DEMKO 04 ATEX0334817 EEx ia IIA T4

The standard sensor (pulser) is a Hall Effect device, which may have one or two output signals. To retain above ratings, it must be powered from a secure circuit through an approved barrier. A PIA-300 signal conditioner may be required, when connected to non-FPP electronics

Specifications:

- Operating speed : 0-100 kHz.
- Operating temperature : -40°F/+300°F (-40°C to +150°C)
- Supply voltage : 4-28 VDC
- Supply current : 13.5 mA max.
- Output type : SINK (add PIA-300 for source)
- Output voltage @ 20 mA: 0.40 V max
- Output sink current : 20 mA max
- Leakage current : 10 µA max
- Magnetics type : Bipolar, operated with alternating north & south magnetic poles.
- Internal pull-up resistor : 10KΩ
- Transmission distance : Max. 100' (30 m) without PIA-300

Pull-up Resistor (R1 & R2)

The sensor has one internal 10KΩ pull-up resistor for each output signal. If used directly with non-Tuthill electronics, verify whether this is adequate for solid communications.

Cable

24 AWG, foil shield & drain wire, blue PVC jacket, RoHS. 75VDC. Capacitance: 185 nF/km. Inductance: 0.65 mH/km. Standard with 18" (45 cm) leads. 120" (305 cm) or 480" (1220 cm) leads optional.

Color Code:

- Red Positive, 4-28VDC
- Black Negative (signal common)
- White Signal output A
- Green Signal output B (optional)

CAUTION
If the sensor is connected incorrectly, it will be damaged beyond repair.

3 conductor: Standard Hall Effect sensor

4 conductor: Dual signal Hall Effect sensor (Quadrature)

2 conductor: Optional Reed Switch sensor (see page 1.9).

A PIA-300 amplifier is required for cable lengths exceeding 100' (30 m).

Easy Identification of replacement sensors

 Black anodized housing is for **TM04 & TM06** models.

 Metallic finish is for use in **TM02 & TM03** models

Installation

Do NOT remove the sensor (pulser) from the flow meter, unless trouble shooting has indicated a problem in the sensor. To remove the sensor, loosen the lock nut on the sensor retainer (sensor well in model TM06). The sensor can now be pulled out.

To install a new sensor, look at the top of the replacement sensor. An internal PC board is visible through the epoxy (usually protrudes slightly from the epoxy). This PC board must be aligned **parallel** with a line drawn between flow meter inlet and outlet.

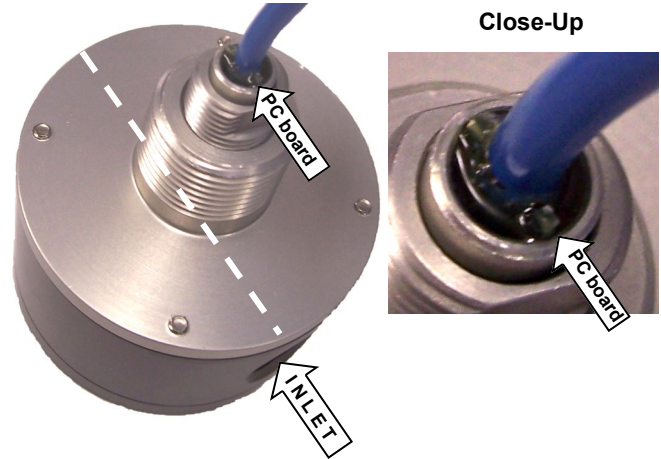

Trouble Shooting the Sensor

There are **three components** to be examined to determine why there is no pulse count coming from the flow meter:

1. Flow meter with magnets in the oval gears.

- Verify that liquid is flowing.
- Verify that sensor (pulser) cable is intact.

2. The sensor (pulser)

- Remove the sensor from the flow meter. Expose the black & white leads (in dual signal sensors, also the green lead). This can be done at a convenient junction, or at the register.
- Use an volt meter to measure the voltage between the white & black leads. It should be nearly equal to the power supply voltage provided on the red lead.
- Pass a magnet across the tip of the sensor. The voltage must switch to nearly zero (less than 0.2 V). If the magnet does not actuate the sensor, the sensor has failed.
- For two channel sensors, repeat this test across black & green leads.

3. The counter (or receiving instrument)

- If liquid is flowing, and the sensor reacts to a magnet, the problem is in the counter/receiving instrument (or possibly in a signal conditioner installed between the sensor & counter/receiving instrument. Please refer to the manual for the this device.

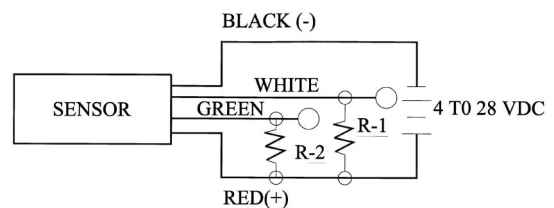

See Control Drawing on page 1.10

Reed Switch

This sensor is strictly for use with battery powered stand-alone registers, where no external power source is available. If external power is available, Hall Effect pulser should be used - even when the register is battery powered.

In so called 'pulse meter' service, either Hall Effect or Quadrature Hall Effect pulser must be used - depending upon the requirements of the receiving instrument.

The Reed Switch sensor (pulser) consists of a set of contacts, hermetically sealed in a glass tube, protecting the contacts from dirt and corrosion of the the outside world. Contacts are actuated by an external magnetic field, provided by permanent magnets inside the rotors.

This is a mechanical device with a finite life. To extend pulser life, flow meters with Reed Switch pulser are only available in 'low resolution' version.

When the pulser starts to wear out, it rarely fails instantly. Instead it starts to miss pulses. We recommend that the flow meter be recalibrated on a regular basis. Once pulser failure is detected, establish a schedule for pulser replacement as a matter of normal maintenance.

Contact Rating:

- Volts DC max. : 30 VDC
- Amps DC max. : 0.01 A
- Watts DC max. : 0.25 W
- Initial resistance : 1.0 Ω
- Operating Temp range : -40°F/+300°F (-40°C/+150°C)
- D-Must operate : 0.125" (3.2 mm)
- D-Must release : 0.400" (10.2 mm)
- Cable specifications:
24 AWG, foil shield & drain wire, blue PVC jacket, RoHS.
75VDC. Capacitance: 185 nF/km. Inductance: 0.65 mH/km.
Standard with 18" (45 cm) leads. 120" (305 cm) optional.

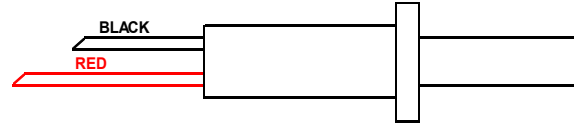

When powered through an approved barrier, Reed Switch sensors are Intrinsically Safe.

Trouble Shooting the Sensor

CAUTION: Do NOT use an Ohm-meter to test the reed switch sensor (pulser).

Remove the sensor from the flow meter, and expose the red & black leads. This can be done at a convenient junction, or at the register.

- Measure the voltage between the red & black leads. It should be equal to the voltage provided by the register.
- Pass a magnet across the tip of the sensor, the voltage should switch to zero (less than 0.2 V).

If the magnet cannot activate switching of the sensor, then the sensor has failed and must be replaced. There are no alignment requirements for the Reed Switch sensor.

When a TM Series flow meter is to be used with an electronic register requiring dual channel signal (Quadrature signal), the SCL signal conditioner is used. This produces a simulated **Quadrature** signal for the register, which will record volume correctly, but it does not permit detection of reverse flow.

The SCL is voltage specific. The standard version can be field selected for 5VDC regulated, or 6-12VDC non-regulated. An optional version is available for 24VDC service.

The SCL can be mounted:

- In a separate enclosure inside the case of the primary register (such as the EMR³ electronic register).
- In a NEMA 4X enclosure, either mounted on the flow meter, or installed remote.
- In a NEMA 7/4X enclosure, either mounted on the flow meter, or installed remote.

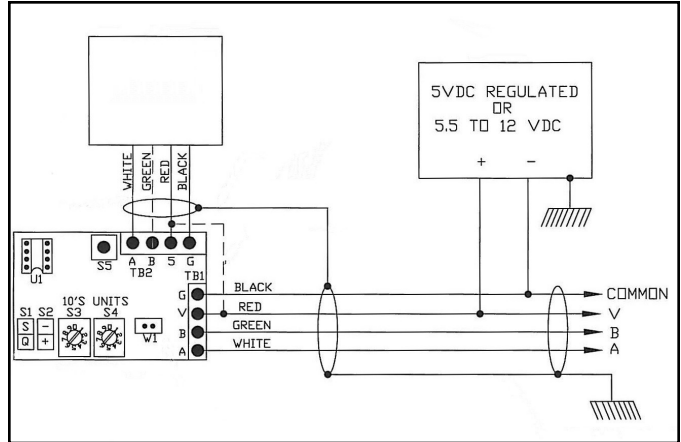

SCL wired to EMR3 register

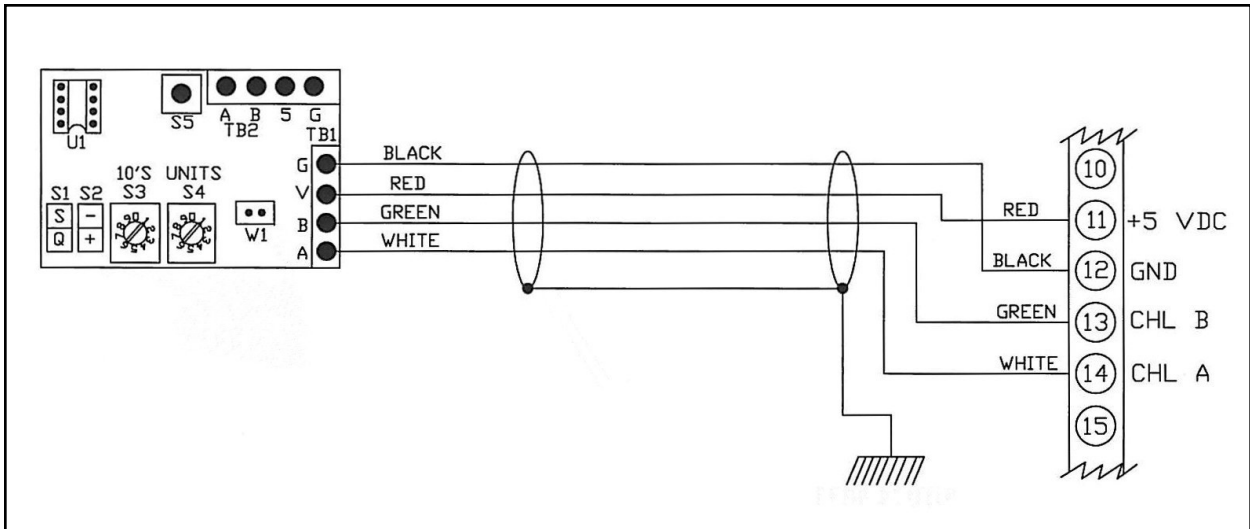

HE pulser (DC powered) to CC56 register (battery powered)

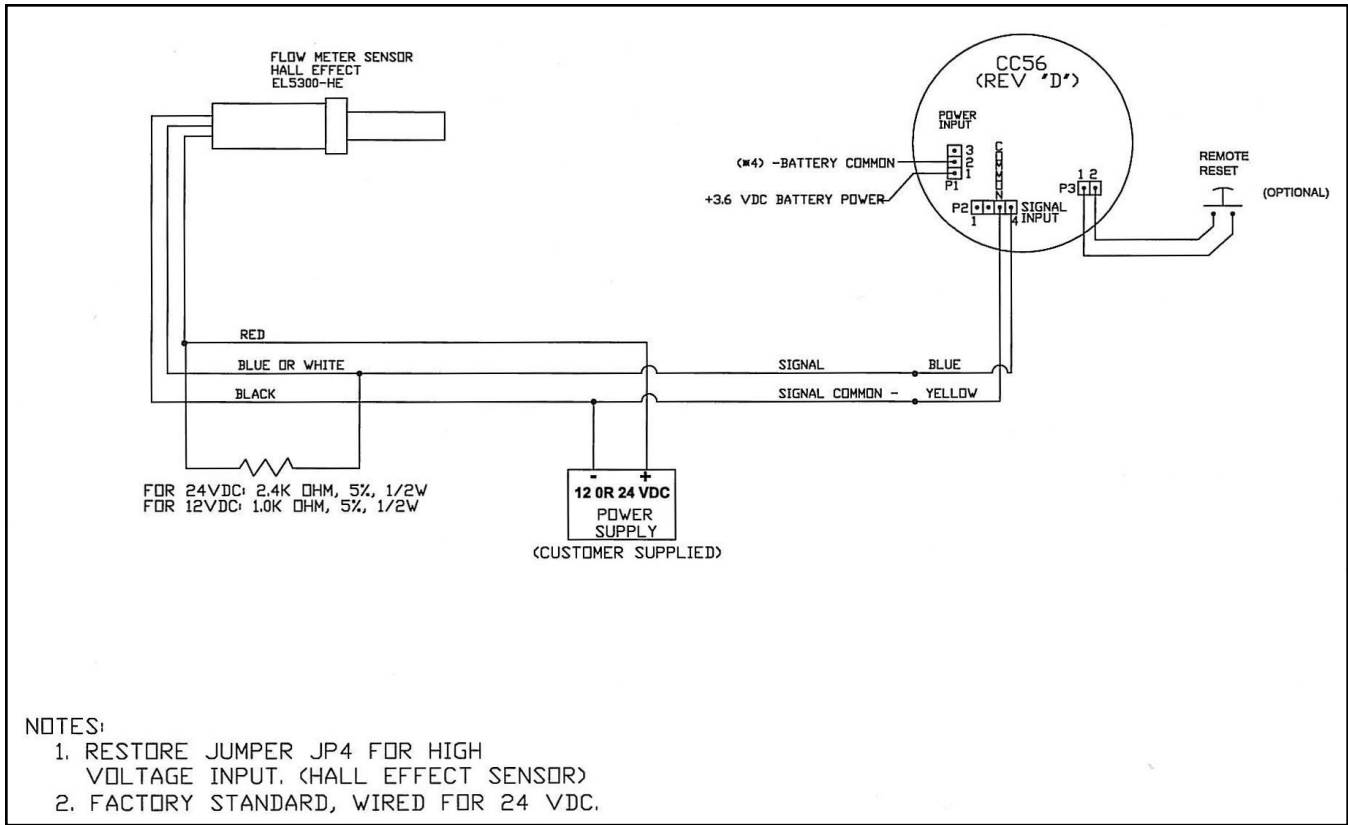

HE pulser (DC powered) to PIA-300 with Channel A to CC56 register, Channel B = pulse output to ??

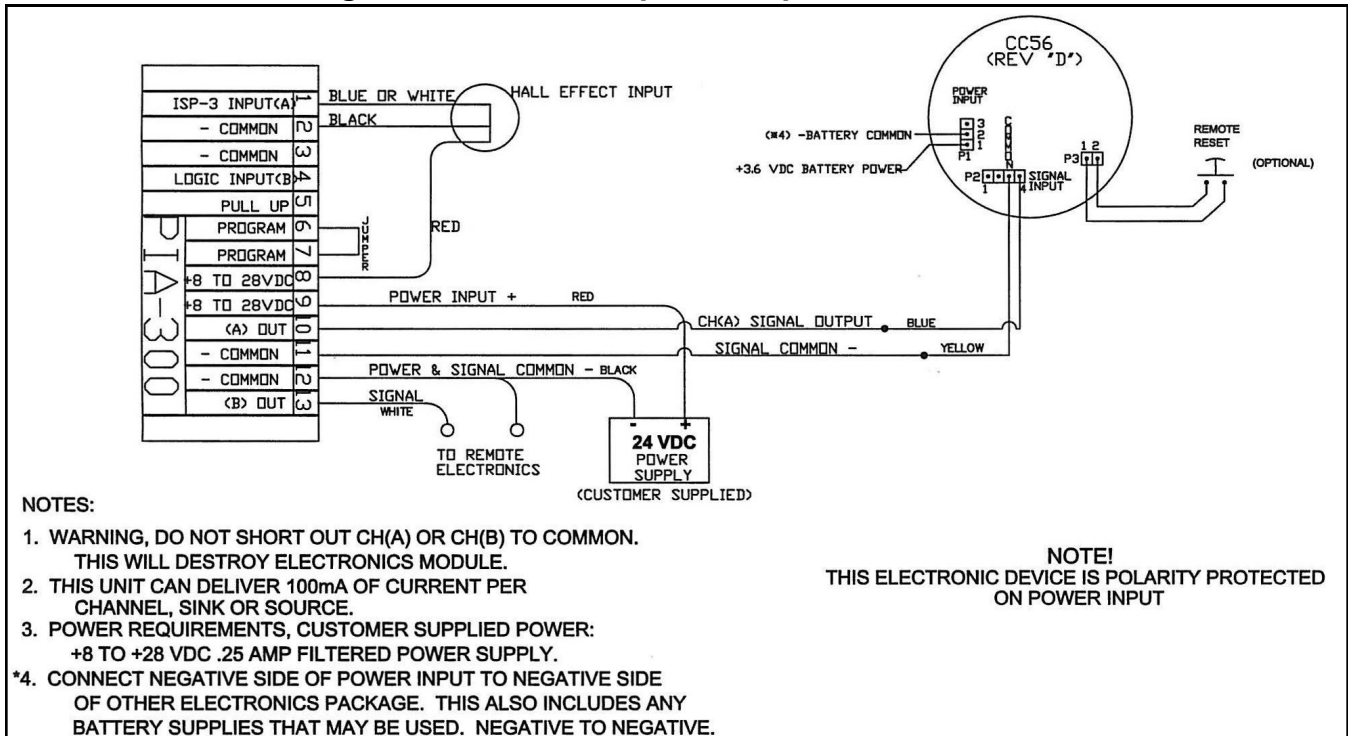

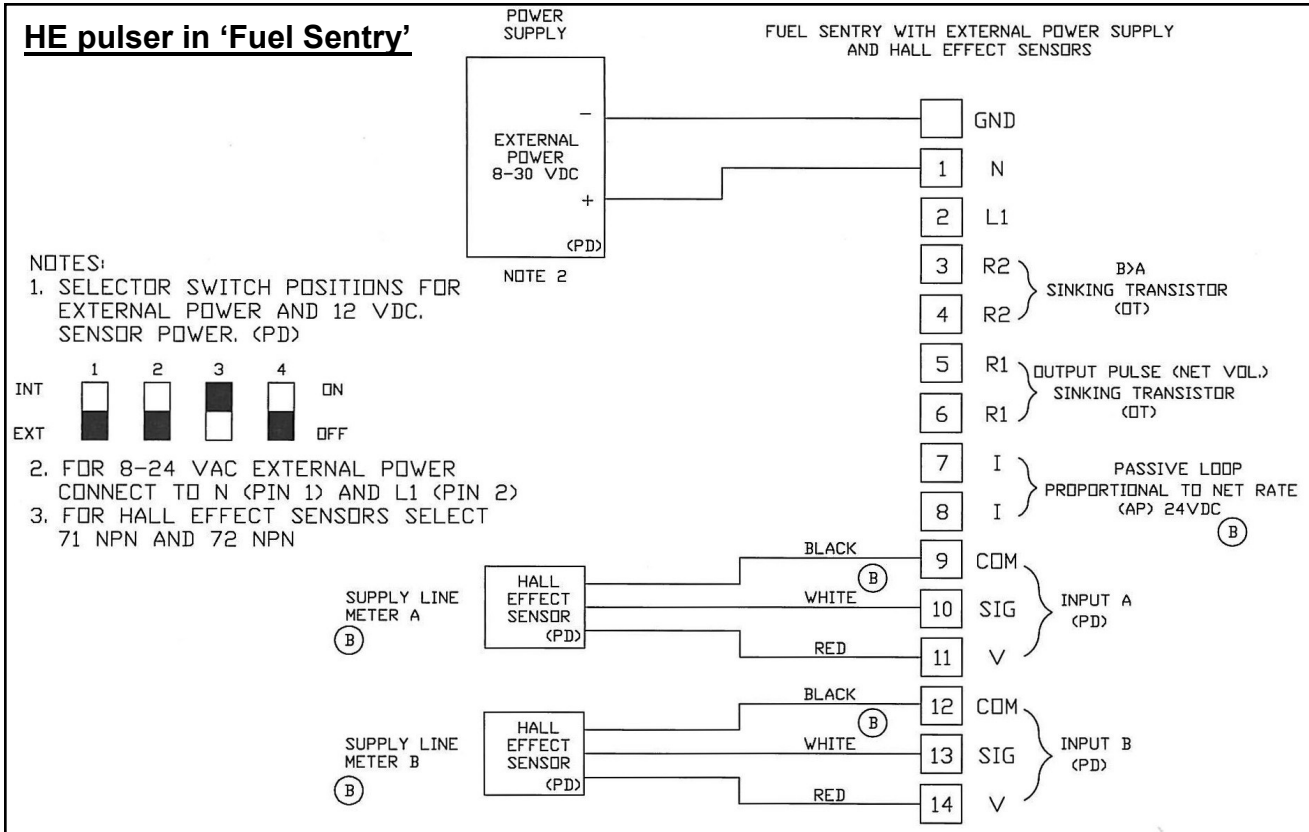
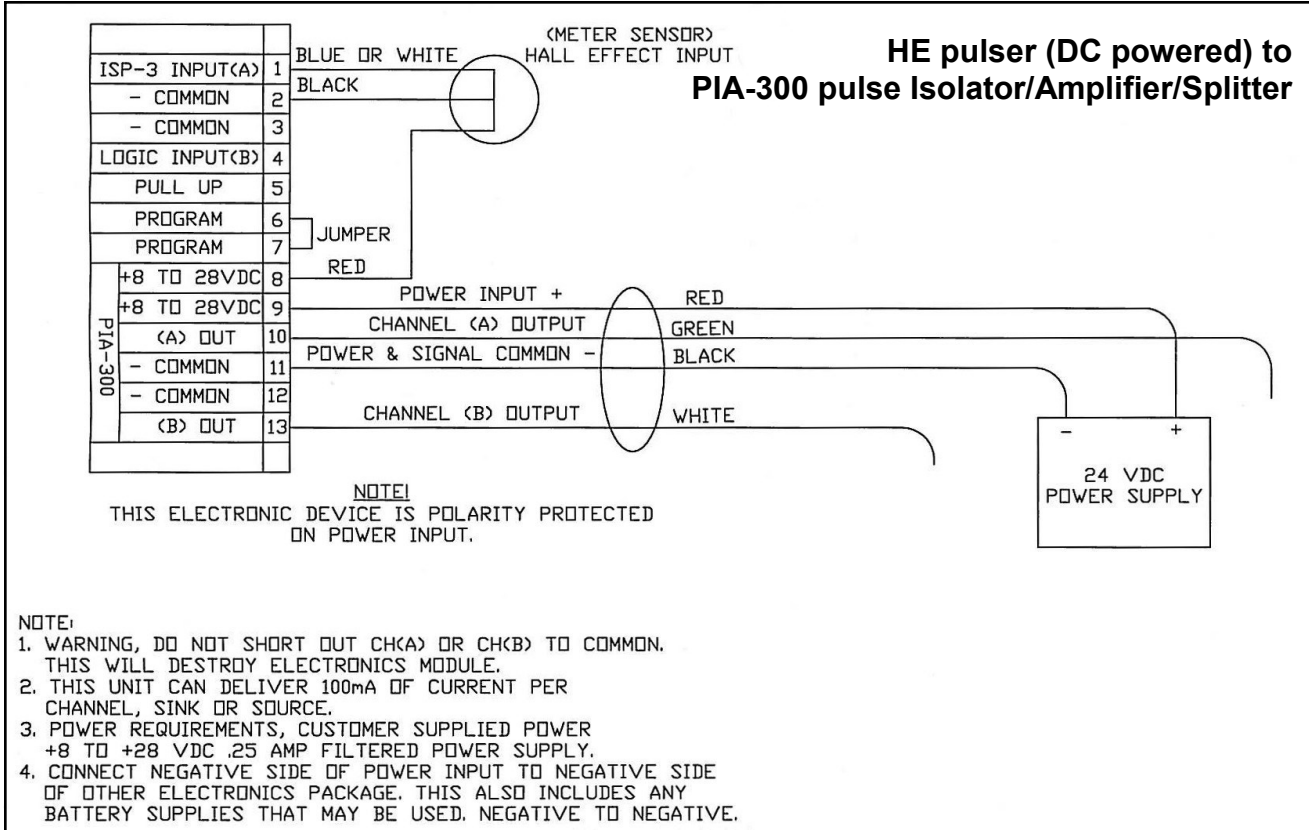

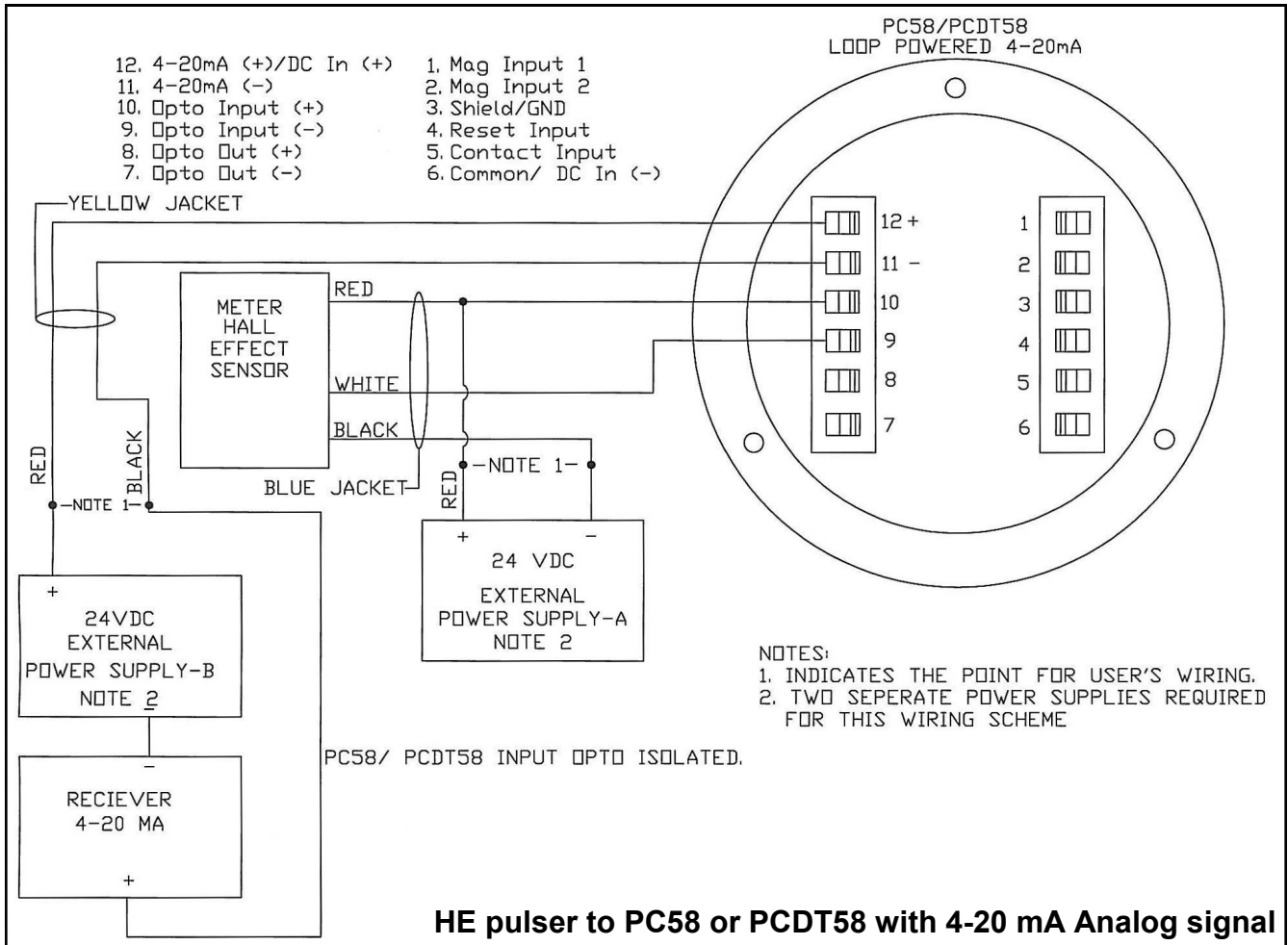
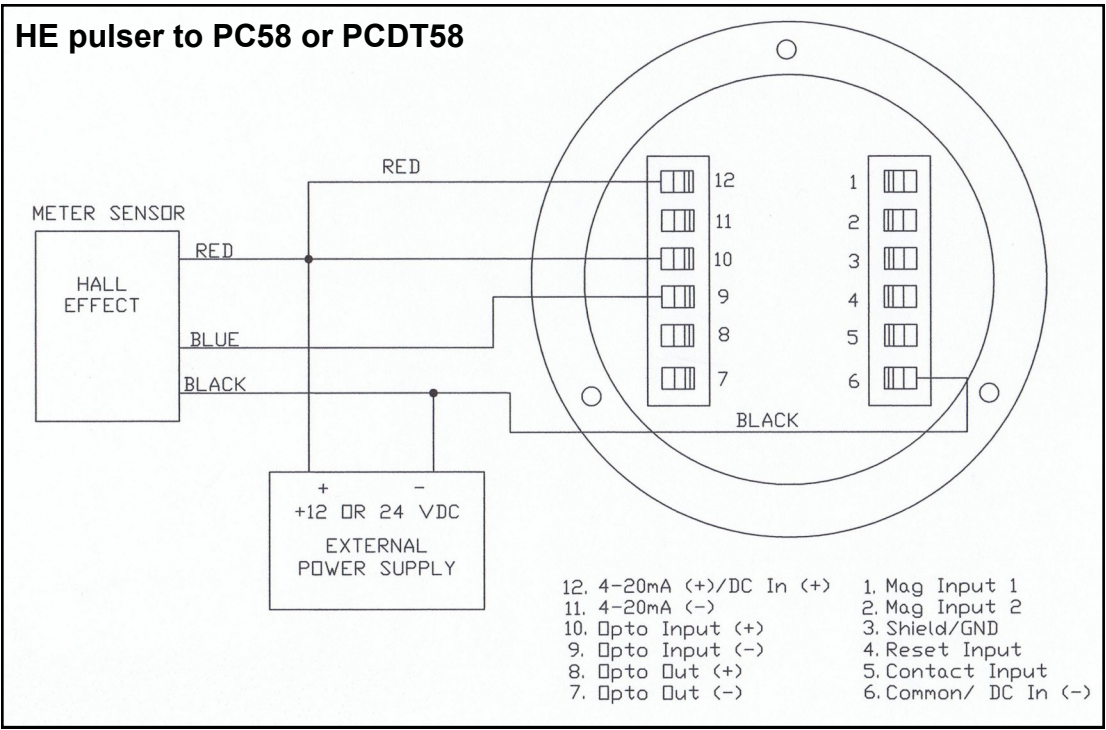

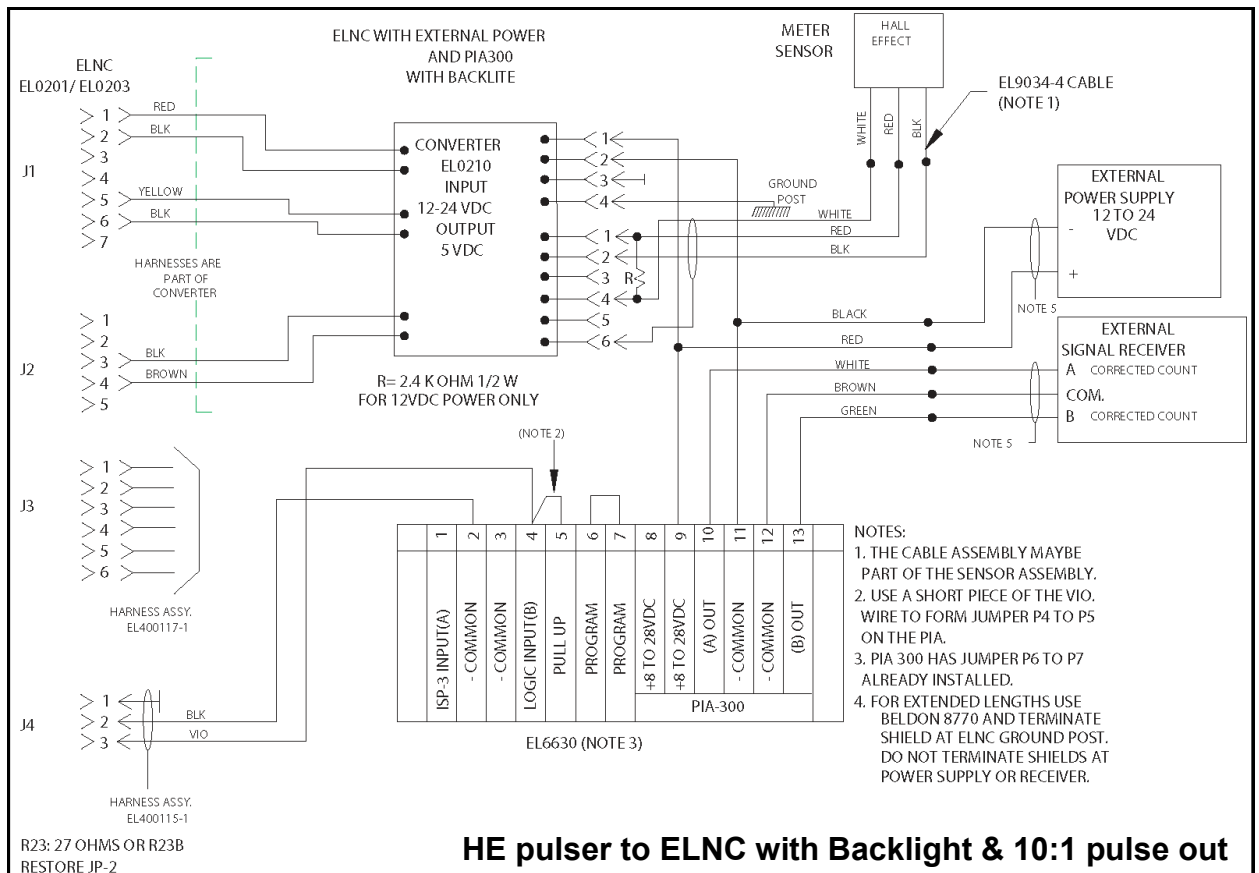
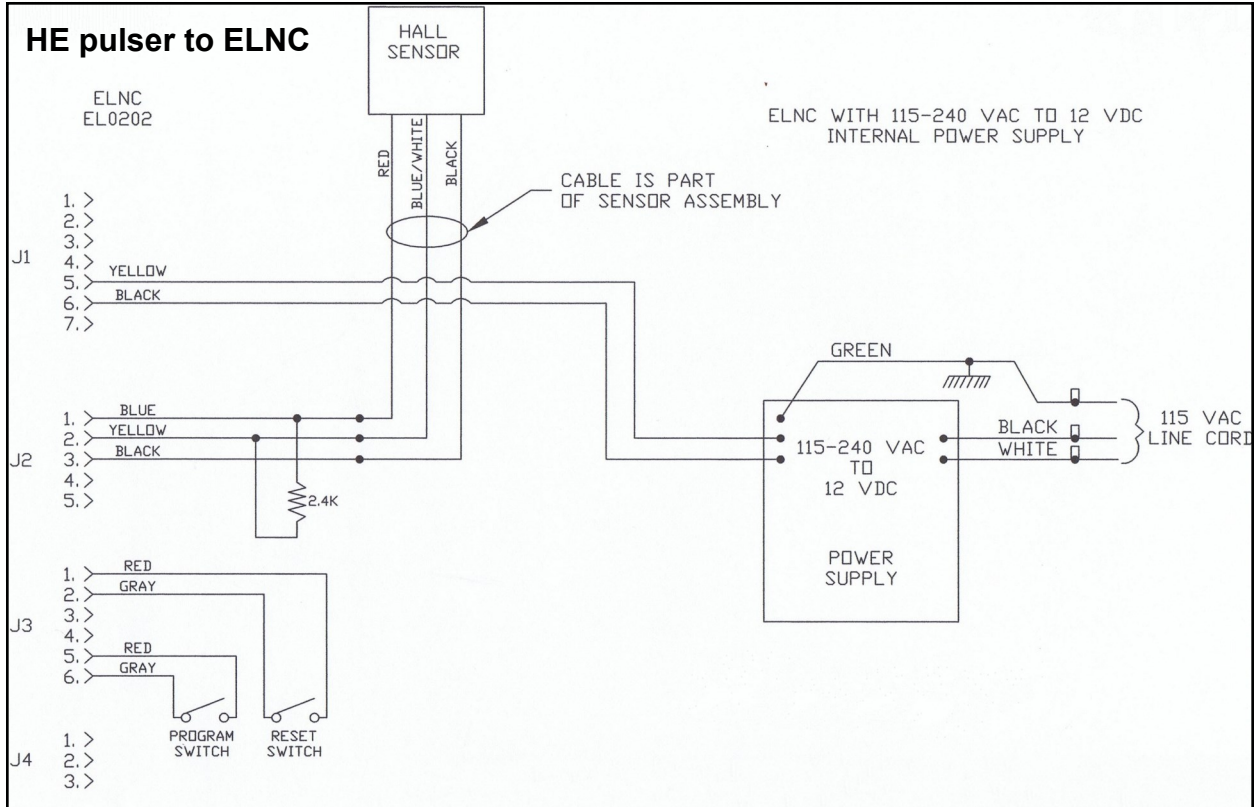

HE pulser to ELNC with Backlight & 10:1 pulse out

HE pulser with EL2057 & ELNC for use in Hazardous Zone

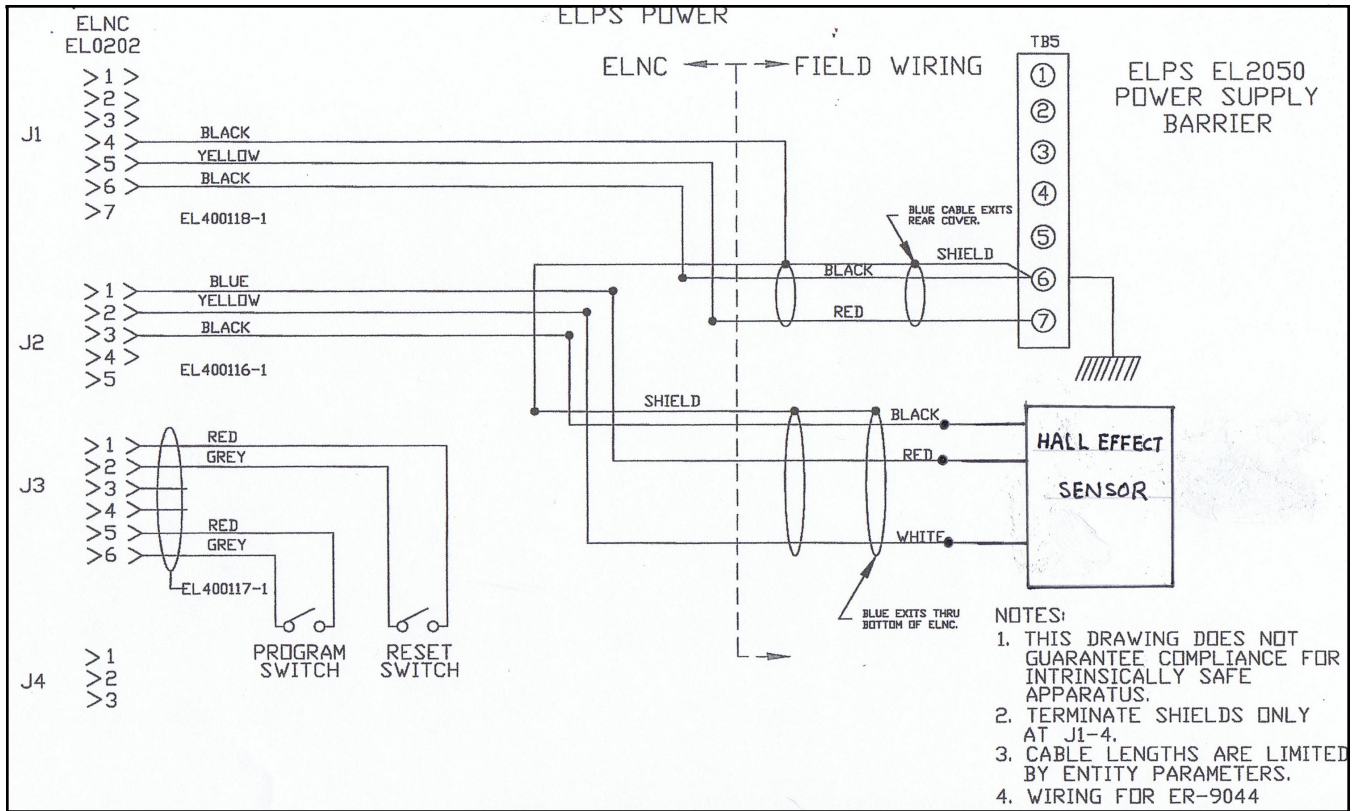

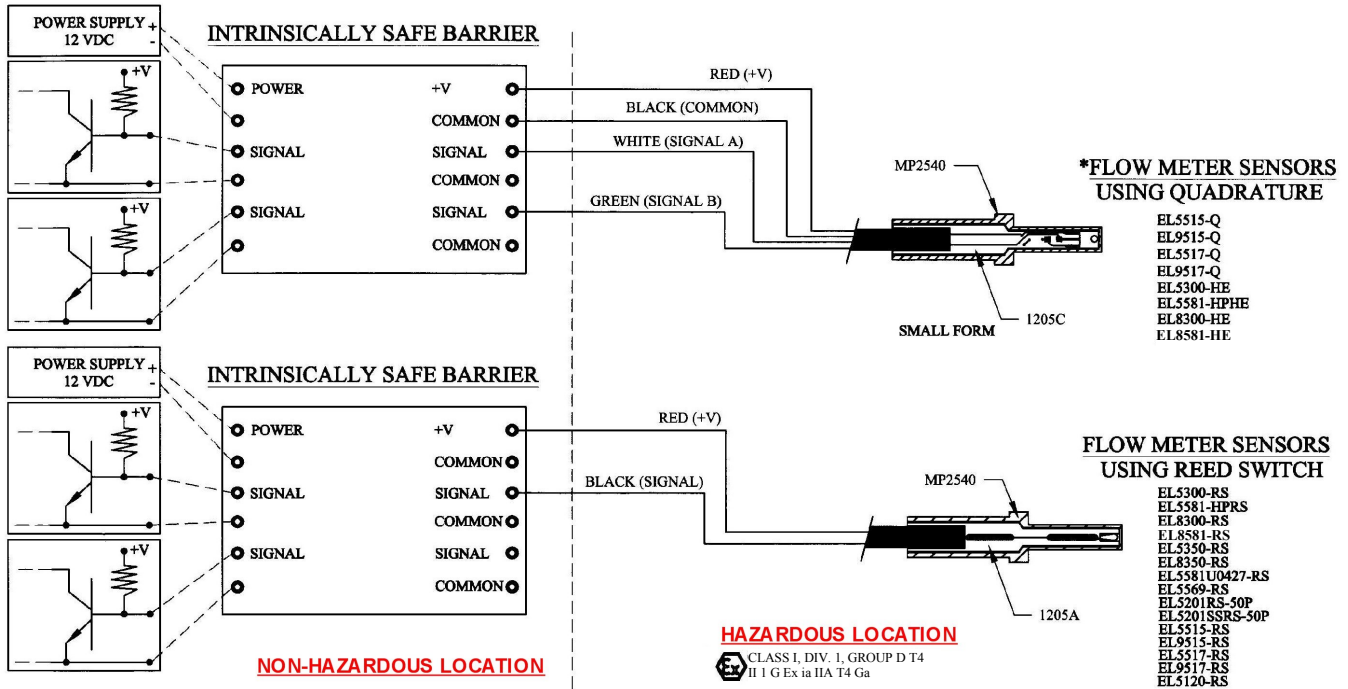

THE FLOW METER SENSORS ARE CONFIGURED IN THREE ELECTRONIC TYPES AND THREE MECHANICAL TYPES.

ELECTRONIC TYPES

1. SINGLE ELEMENT HALL EFFECT SENSOR WITH THREE WIRE CONNECTIONS.
2. DUAL ELEMENT HALL EFFECT SENSOR WITH FOUR WIRE CONNECTIONS.
3. SINGLE ELEMENT REED SWITCH SENSOR WITH TWO WIRE CONNECTIONS.

MECHANICAL TYPES

1. SMALL FORM WHICH DOES NOT ENTER INTO THE WETTED ENVIRONMENT OF THE FLOW METER.
2. LARGE FORM WHICH ENTERS THE WETTED ENVIRONMENT OF THE FLOW METER.
3. EL5120 WHICH HAS A SPECIAL HOUSING FORM.

NOTES:

1. WHERE MULTIPLE CIRCUITS EXTEND FROM THE SAME PIECE OF INTRINSICALLY SAFE EQUIPMENT, THEY MUST BE INSTALLED IN SEPARATE CABLES OR IN ONE CABLE HAVING SUITABLE INSULATION. REFER TO INSTRUMENT SOCIETY OF AMERICA RECOMMENDED PRACTICE ISA RP12.6 FOR INSTALLING INTRINSICALLY SAFE EQUIPMENT.
2. BARRIERS MAY BE IN A DIVISION 2 OR ZONE 2 LOCATION IF SO APPROVED.
3. BARRIER OUTPUT CURRENT MUST BE LIMITED BY A RESISTOR SUCH THAT THE OUTPUT VOLTAGE-CURRENT PLOT IS A STRAIGHT LINE DRAWN BETWEEN OPEN-CIRCUIT VOLTAGE AND SHORT-CIRCUIT CURRENT.
4. SELECTED BARRIERS MUST BE THIRD PARTY APPROVED AS PROVIDING INTRINSICALLY SAFE CIRCUITS FOR THE APPLICATION, AND HAVE Voc OR Vt NOT EXCEEDING Vmax OR Uo NOT EXCEEDING Ui, AND Isc OR It NOT EXCEEDING Imax OR Io NOT EXCEEDING Ii, AND THE Po OF THE BARRIER MUST BE LESS THAN OR EQUAL TO THE Pmax OR Pi OF THE INTRINSICALLY SAFE EQUIPMENT, AS SHOWN IN TABLE 1.
5. CAPACITANCE AND INDUCTANCE OF THE FIELD WIRING FROM THE INTRINSICALLY SAFE EQUIPMENT TO THE BARRIER SHOULD BE CALCULATED AND SHOULD BE INCLUDED IN THE SYSTEM CALCULATIONS AS SHOWN IN TABLE 1. CABLE CAPACITANCE (Cc) PLUS INTRINSICALLY SAFE EQUIPMENT CAPACITANCE (Ci) MUST BE LESS THAN THE MARKED CAPACITANCE (Ca OR Co) SHOWN ON ANY BARRIER USED. THE SAME APPLIES FOR INDUCTANCE (Lc, Li AND La OR Lo RESPECTIVELY). WHERE THE CABLE CAPACITANCE AND INDUCTANCE PER FOOT ARE NOT KNOWN, THE FOLLOWING VALUES SHALL BE
Cc = 60 pF/ft. > [200pF/m], Lc = 0.2uH/ft [1uH/m]

IF Po OF THE BARRIER IS NOT KNOWN, IT MAY BE CALCULATED USING THE FORMULA $P_o = (V_{oc} * I_{sc})/4 = (U_o * I_o)/4$.

7. BARRIERS MUST BE INSTALLED IN ACCORDANCE WITH BARRIER MANUFACTURER'S CONTROL DRAWING AND ARTICLE 504 OF THE NATIONAL ELECTRICAL CODE, ANS/NFPA 70, FOR INSTALLATION IN THE UNITED STATES, OR SECTION 18 OF THE CANADIAN ELECTRICAL CODE FOR INSTALLATIONS IN CANADA.
8. WHEN REQUIRED BY THE MANUFACTURER'S CONTROL DRAWING, THE BARRIER MUST BE CONNECTED TO A SUITABLE GROUND ELECTRODE PER THE NATIONAL ELECTRICAL CODE, ANS/NFPA 70, OR THE CANADIAN ELECTRICAL CODE, OR OTHER LOCAL INSTALLATION CODES AS APPLICABLE. THE RESISTANCE OF THE GROUND PATH MUST BE LESS THAN 1 OHM..
9. CONTROL EQUIPMENT MUST NOT USE OR GENERATE MORE THAN 250 V RMS OR DC WITH RESPECT TO EARTH.

Vmax, Ui	Imax, Ii	Pi	Ci	Li
30V	500ma	1.3W	0	0

INTRINSICALLY SAFE FOR CLASS I, DIV. 1, GROUP D TEMPERATURE CODE T4

CE1725 II 1 G
DEMKO 04 ATEX 0334817X
-20°C < Ta < +40°C

TABLE 1:

I.S. EQUIPMENT	BARRIER
Ui, V MAX	Voc (OR Vt), Uo
Ii, I MAX	Isc (OR It), Io
Pi, P MAX	Po
Ci + Cc	Ca, Co
Li + Lc	La, Lo

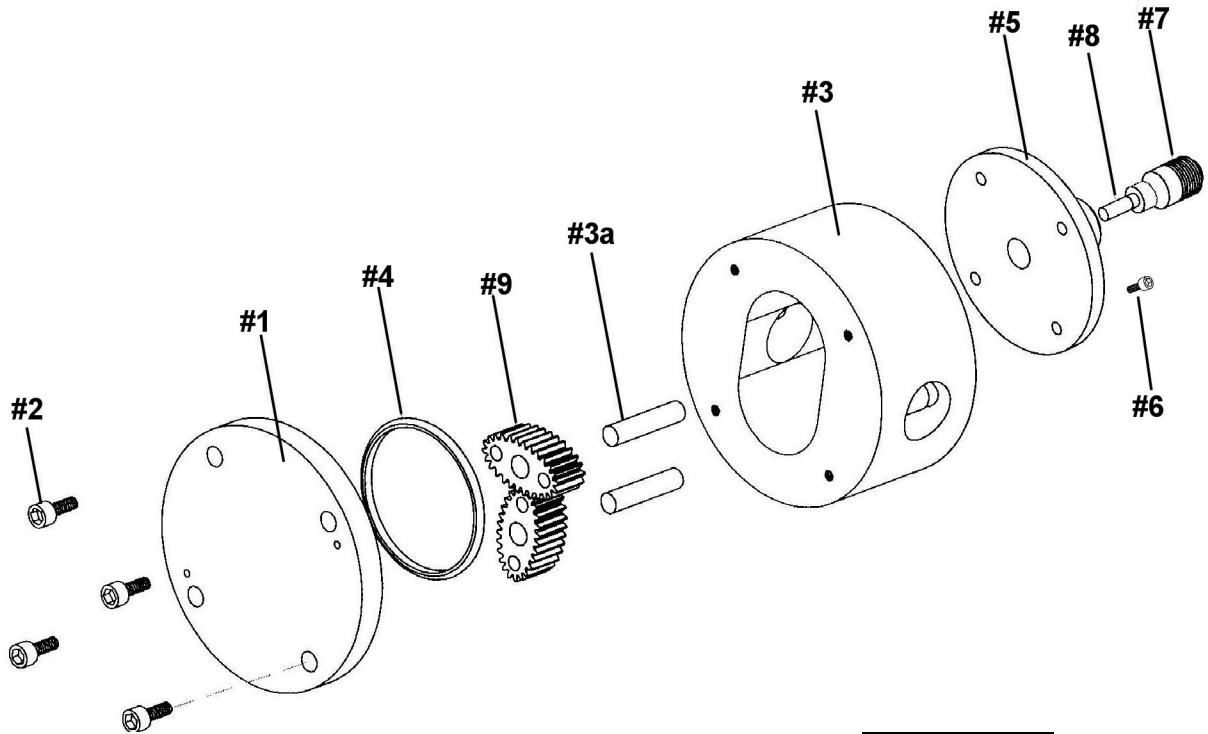

2009: 400 PSI (28 BAR) version being phased out

		TM02D	
		Stainless Steel	
		400 PSI	1500 PSI
REF	Description	28 BAR	103 BAR
1.	Meter cover plate	CP86502	CP8625
2.	Screw , cover plate (10-32 X 3/8" SHCS 303SS) Screw , cover plate (10-32 X 5/8" ALSTHCS)	FS9651	FS1660
3.	Meter body w ith posts, 1/4" NPT ports Meter body w ith posts, 1/4" BSP ports		MB99011 MB99021
4.	O-ring, cover plate, Teflon		SL2029
5.	Pulser retainer ('Top Hat')		MP2084
6.	Screw , pulser retainer (8-32 x 1" SHCS SS)		FS9540
7.	Lock nut		MP2541

Standard pulser/gear set:

8.	Standard Hall Effect sensor (pulser). <i>When used with non-Tuthill electronics, a PIA-300 signal conditioner is often required.</i>	1	EL5300-HE
9.	Gear set: SS/Teflon bearings, 2 magnets Nominal K Factor: 7700 PPG (2035 ppl)	1	GSTM02-2

Optional pulser/gear set:

8.	Optional reed sw itch sensor (pulser), <i>For use with Tuthill battery powered electronic register.</i>	1	EL5300-RS
9.	Gear set: SS/Teflon bearings, 1 magnet Nominal K Factor: 3850 PPG (1018 ppl)	1	GSTM02-1

K Factor (pulse resolution) is nominal . Individual flow meters vary, and are subject to up to 3-4% shift on liquids w ith viscosity > 100 cSt.

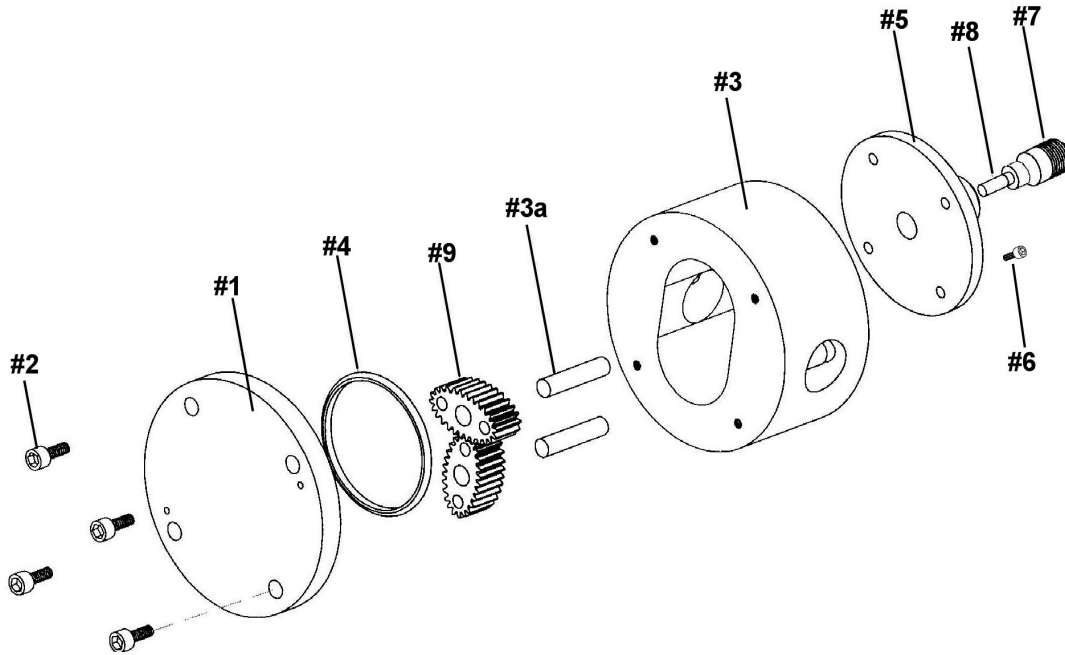

2009: 400 PSI (28 BAR) version being phased out

REF	Description	QTY	TM03A		TM03D		
			Anod. Aluminum	Stainless Steel	400 PSI	1500 PSI	400 PSI
			28 BAR	103 BAR	28 BAR	103 BAR	
1.	Meter cover plate	1	CP2800	CP2850	CP9800	CP9650	
2.	Screw , cover plate (10-32 X 3/8" SHCS 303SS) Screw , cover plate (10-32 X 5/8" ALSTSHCS)	6	FS9651	FS1660	FS9651	FS1660	
3.	Meter body w ith posts, 3/8" NPT ports Meter body w ith posts, 3/8" BSP ports	1	MB2800-21 MB2801-21		MB980021 MB980121		
4.	O-ring, cover plate, Viton O-ring, cover plate, Teflon	1	SL1033 (std.) SL2033 (opt.)		na SL2033		
5.	Pulser retainer ('Top Hat')	1	MP2085		MP2085		
6.	Screw , pulser retainer (6-32 x 1.1/2" SNCS SS)	4	FS9450		FS9450		
7.	Lock nut	1	MS2541		MS2541		
8.	Hall Effect sensor (pulser). <i>When used with non-Tuthill electronics, a PIA-300 signal conditioner is often required.</i>	1	EL5300-HE				
9.	PPS, Low viscosity/temperature Gear Set	1	GS530R2600 (std. 2009+) GS530R1300 (std. pre-2009) GS530RMV2600 (optional) GS530RMV1300 (optional) SS gears w ith Teflon bearing Nom. 2800 PPG (740 ppl) Nom. 1400 PPG (370 ppl) GSTM03CT-4 (optional) Low viscosity/any temperature Nom. 2800 PPG (740 ppl) Nom. 1400 PPG (370 ppl) GSTM03CT-2 (optional)				
8.	Reed Sw itch sensor (pulser), <i>For use with Tuthill battery powered electronic register.</i>	1	EL5300-RS (optional)				
9.	PPS, Low viscosity/temperature Gear Set	1	GS530R650 (optional) GS530RMV650 (optional) GSTM03CT-1 (optional)				

K Factor (pulse resolution) is nominal . Individual flow meters vary, and are subject to up to 3-4% shift on liquids w ith viscosity > 100 cSt.

TM04A, TM04C & TM04D Parts List

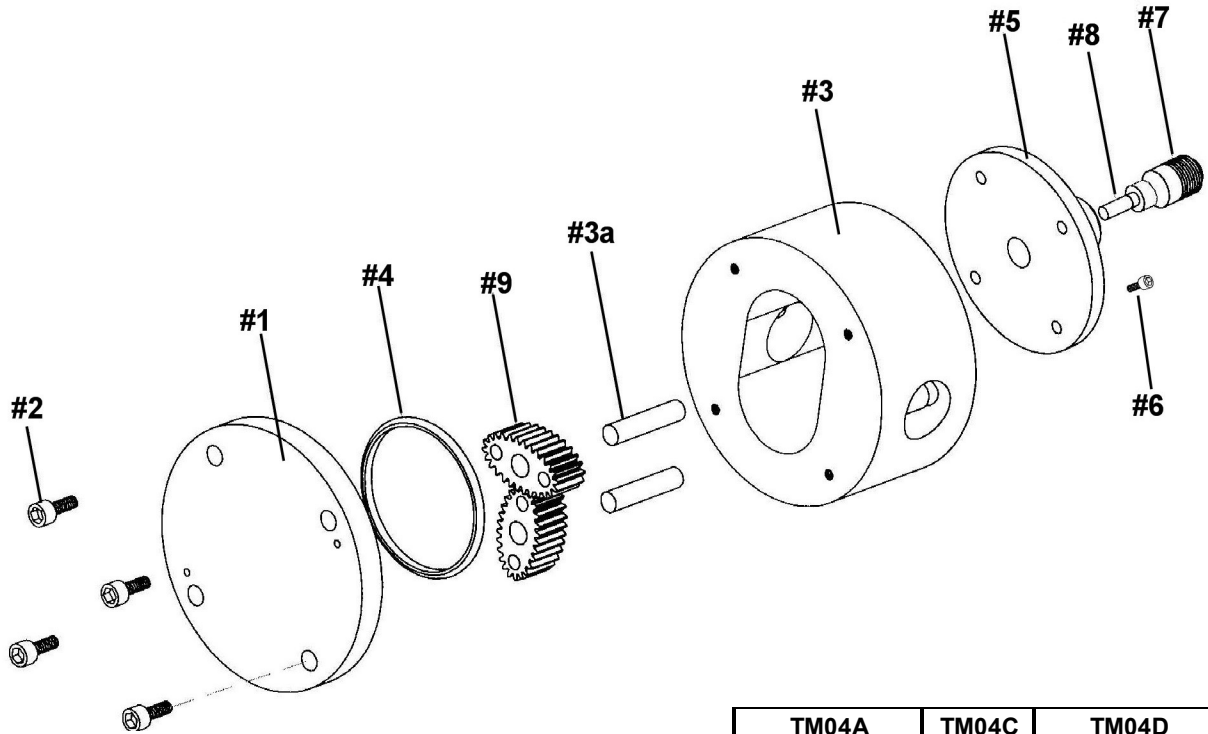

2009: 400 PSI (28 BAR) version being phased out

REF	Description	QTY	TM04A		TM04C	TM04D	
			Anod. Aluminum		303 SS	316 Stls. Steel	
			400 PSI 28 BAR	1500 PSI 103 BAR	2500 PSI 173 BAR	400 PSI 28 BAR	1500 PSI 103 BAR
1.	Meter cover plate	1	CP2501	CP2506C	CP8575	CP9500	CP9501
2.	Screw , cover plate (1/4-20 x 1/2 SHCS, SS)	4	FS9812			FS9812	
	Screw , cover plate (1/4-20 x 5/8 SHCS)			FS1802			FS1802
					FS1901		
3.	Meter body w ith posts, 1/2" NPT ports	1	MB25011		MB8575-1	MB95011	
	Meter body w ith posts, 1/2" BSP ports		MB25021			MB95021	
4.	O-ring, cover plate, Viton	1	SL1138 (std.)			na	
	O-ring, cover plate, Teflon		SL2138 (opt.)		SL2138	SL2138	
5.	Pulser retainer ("Top Hat")	1	MP2086		MP8550	MP2086	
6.	Screw , pulser retainer (8-32 x 1" SHCS SS)	4	FS9812		FS1901	FS9812	
7.	Lock nut	1	MS2541		MP2541	MS2541	
8.	Hall Effect sensor (pulser). <i>When used with non-Tuthill electronics, a PIA-300 signal conditioner is often required.</i>	1			EL5581-HPHE		
9.	PPS, Low Viscosity/Temperature	Nom. 805 PPG (213 ppl)				GS540R380 (std. 2009+)	
Gear		Nom. 403 PPG (106 ppl)				GS540R760 (std. pre-2009)	
Set	PPS, High Temperature (or high viscosity)	Nom. 805 PPG (213 ppl)				GS540RMV380 (optional)	
		Nom. 403 PPG (106 ppl)				GS540RMV760 (optional)	
8.	Reed Sw itch sensor (pulser), <i>For use with Tuthill battery powered electronic register.</i>	1				EL5581-HPRS (optional)	
9.	PPS, Low Viscosity/Temperature					GS540R190 (optional)	
	PPS, High Temperature (or high viscosity)					GS540RMV190 (optional)	

K Factor (pulse resolution) is nominal. Individual flow meters vary, and are subject to up to 3-4% shift on liquids w ith viscosity > 100 cSt.

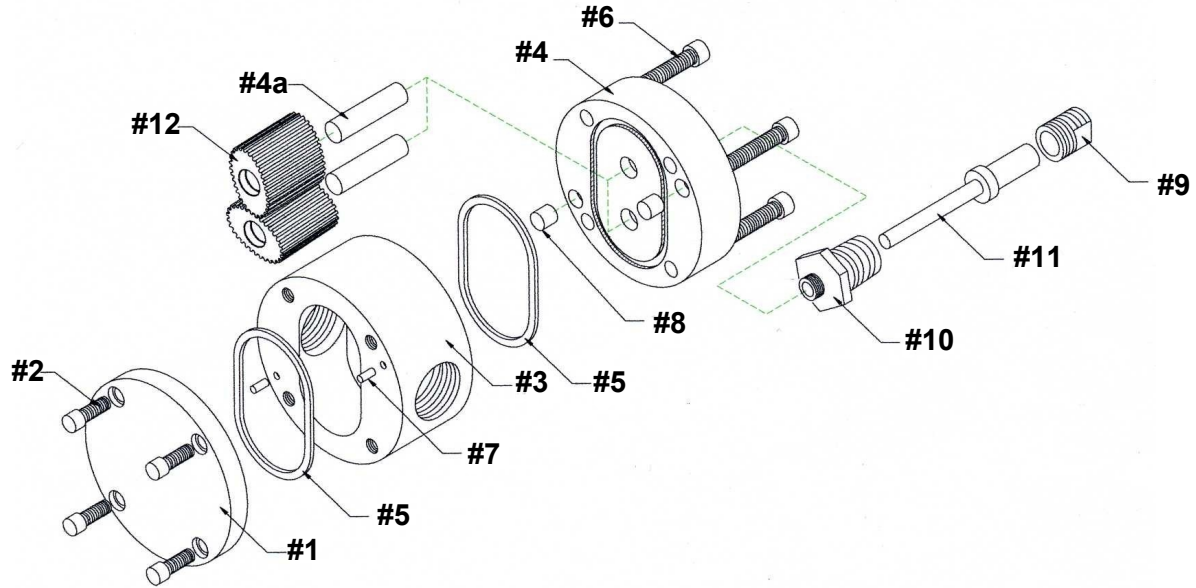

2009: 400 PSI (28 BAR) version being phased out

2010: 303SS/1500 PSI version being phased out

303SS/2500 PSI special production, availability subject to min. qty.

REF	Description	QTY	TM06A		TM06C		TM06D			
			Anod. Aluminum		303 Stls. Steel		316 Stls. Steel			
			400 PSI 28 BAR	1500 PSI 103 BAR	1500 PSI 103 BAR	2500 PSI 173 BAR	400 PSI 28 BAR	1500 PSI 103 BAR		
1.	Meter cover plate	1	CP2502	CP2508	CP9415	CP8404HP	CP9404	CP9415		
2.	Screw , cover plate (1/4-20 x 1/2 SHCS)	4	FS9812				FS9812			
	Screw , cover plate (1/4-20 x 5/8 SHCS)	4		FS1802	FS1802			FS1802		
3.	Meter body, 3/4" NPT ports	1	MB2600		MB8400	MB8400HP		MB9401		
	Meter body, 3/4" BSP ports		MB2601		MB8401	MB8401HP		MB9402		
4.	Post plate assy (must be replaced as a set), consists of Post plate (NSS) & 2 Posts (NSS)	1	CP26011		CP84081			CP96011		
5.	O-ring, cover & post plate, Viton	2	SL1138 (std.)		na	na		na		
	O-ring, cover & post plate, Teflon		SL2138 (opt.)		SL2138	SL2138		SL2138		
6.	Screw , post plate (1/4-20 x 1.00 SHCS)	4	FS2800		FS9832			FS9832		
		8				FS1901				
7.	Dow el pin, cover plate/meter body	2	MS2001							
8.	Dow el pin, post plate/meter body	2	MS902118-8							
9.	Lock nut	1	MP2541							
10.	Sensor well	1	MP8550							
11.	Hall Effect sensor (pulser). <i>When used with non-Tuthill electronics, a PIA-300 signal conditioner is often required.</i>	1	EL5581-HPHE							
12.	Low Viscosity/Temperature	Nom. 405 PPG (107 ppl)	1	GS550RC380 (std. 2009+)						
	Gear	Nom. 203 PPG (53.5 ppl)		GS550RC190 (std. pre-2009)						
	Set	High Temperature (or high viscosity)		Nom. 405 PPG (107 ppl)	GS550RC380-MV (optional)					
		Nom. 203 PPG (53.5 ppl)		GS550RC190-MV (optional)						
11.	Reed Sw itch sensor (pulser), <i>For use with Tuthill battery powered electronic register.</i>		1	EL5581-HPRS (optional)						
12.	Low Viscosity/Temperature	Nom. 101 PPG (27 ppl)	1	GS550RC095 (optional)						
	High Temperature (or high viscosity)			GS550RC095-MV (optional)						

K Factor (pulse resolution) is nominal. Individual flow meters vary, and are subject to up to 3-4% shift on liquids with viscosity > 100 cSt.



PIA-300 Pulse Isolator, Amplifier & Splitter (optional component)

The purpose of the PIA-300 is to provide:

- Protection and properly interface the signal from the Hall Effect sensor (pulser) to customer supplied electronics (totalizer, register, PLC, etc.).
- Supply SOURCE signal in place of standard sink.
- Amplification of output signal, so it can be transmitted over greater distances.
- Two identical output signals, which can be sent to two different destinations.

This component can be supplied either unmounted (as an encapsulated circuit pack), or installed in a variety of optional enclosures. In some cases it can be mounted internally in the remote receiving instrument.

- 1 ISP-3 INPUT (A)
- 2 COMMON
- 3 COMMON
- 4 LOGIC INPUT (B)
- 5 PULL UP
- 6 PROGRAM
- 7 PROGRAM
- 8 +8 TO 28VDC
- 9 +8 TO 28VDC
- 10 (A) OUT
- 11 COMMON
- 12 COMMON
- 13 (B) OUT



P/No. EL6630 Specifications

- **Input Signal Device** : Hall Effect sensor (pulser)
- **Max. input frequency** : 0 to 5,000 Hz
- **Power Supply Range** : Filtered DC power required, 8-28 VDC maximum
Customer supplied, 250 mA
- **Idle Current Draw** : 0.10 Amps @ 28 VDC
- **Max. Current Draw, Both Channels** : 200 mA
- **Output Signal** : 100 mA per channel into a 0.1 μ f load, sink or source
750' (230 m) 18-20 AWG wire
- **Connections** : 2.4 mm screwdriver terminals (wire sizes 14-20 AWG)
- **Temperature** : -40°F/+158°F (-40°C/+70°C)
- **Dimensions** : 2.10" x 0.98" x 0.38"
52.5 x 24.9 x 9.5 mm
- **Enclosure options** : Local NEMA 3R
Local or remote NEMA 4X
Local or remote NEMA 7/4X

The PIA-300 is often used in conjunction with **PC58** or **PCDT58** to provide a pulse signal. In those systems, the PIA-300 can be wired in one of two positions:

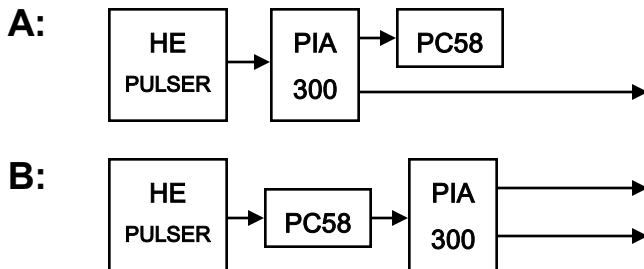

A = High frequency, non-scaled pulse signal to the remote instrument (raw meter signal).

B = Low frequency (max. 8 Hz), scaled pulse signal from the register/totalizer to the remote instrument.

Name _____ Phone _____ Date _____
 Company _____ E-mail _____

To ensure correct selection of flow meter and possible accessories, please provide the following details:

Liquid(s) to be metered:

FLOW RATE:	NORMAL	MIN:	MAX:	GPM	GPH	LPM	LPH	M ³ /H	
TEMPERATURE:		MIN:	MAX:	°F	°C				
PRESSURE:	NORMAL	MIN:	MAX:	PSI	BAR	kg ² /cm	kPa	Pa	Mpa
VISCOSITY:	@ NORM Temp:	@ MIN Temp:		SSU	cSt	mm ² /s	cP	mPa•S	
TYPE of PUMP:									

Circle units used

Type of operation:

Please describe the system (such as: Retail tank truck, rail road fueling in depot, etc.)

When making a choice between mechanical & electronic register, consider that the electronic system has lower maintenance requirements, and it is always more accurate than the equivalent mechanical system due to less drag on the flow meter.

For a single flow meter, the mechanical register is usually the lower initial cost. For 2-3 flow meters in one system/installation, the cost is usually comparable (within 5-10%). For 4 or more flow meters in one system, the electronic solution is usually the lower initial cost.

Custody Transfer service Non-custody transfer, **specify accuracy required**: +/- _____ %

Area classification: Non-Hazardous Hazardous. Distance to nearest non-hazardous location: _____

Accessories:

- Strainer
- Strainer/Air Eliminator
- High Capacity Strainer/Air Eliminator
- Backpressure Valve
- Air Check Valve
- Preset Valve, mechanical
- 2-stage electronic preset valve
- 1-stage system security valve

Registration, Functions & Communications:

- Register Local Remote Local & Remote
- Preset/Batching with pump control
- Printer Local Remote Local & Remote
- Rate of Flow display per MIN HOUR DAY
- Temperature/Volume comp.
- Currency function
- Remote operation
- Pulse signal Resolution/unit: _____ Distance: _____
- Analog signal 4-20 mA 0-20 mA other: _____
- Transaction data to PC Serial Port Wireless
- without register, **specify**: Model: _____
- Voltage: _____

Flanges:

- Threaded companion flanges
- Welding companion flanges
- 150# RF ANSI flange adaptors

In multi-meter systems with EMR³ register, specify distances:

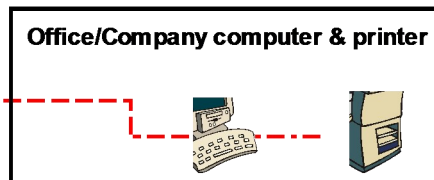
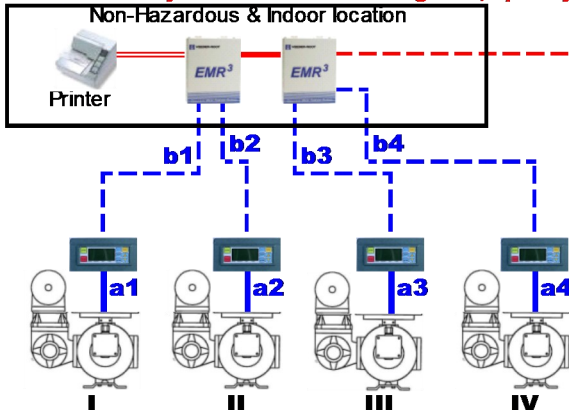

a1 :	b1 :	c1 :	D :
a2 :	b2 :	c2 :	
a3 :	b3 :	c3 :	
a4 :	b4 :	c4 :	
a5 :	b5 :	c5 :	
a6 :	b6 :	c6 :	
a7 :	b7 :	c7 :	
a8 :	b8 :	c8 :	

= 0 if register is installed on flow meter

When BOTH local & remote register, C = the distance from interconnect box to remote register

etc.

NOTES



Tuthill Corporation
8825 Aviation Drive | Fort Wayne, Indiana 46809
P (800) 634-2695 | (260) 747-7524
F (800) 866-4861
www.tuthill.com
www.fillrite.com
www.sotera.com

Tuthill UK LTD.
Birkdale Close Manners Industrial Estate
Ilkeston, Derbyshire
DE7 8YA
UK
P +44 0 115 932 5226
F +44 0 115 932 4816