



The Standard of Measurement

# TCS 3000

## ELECTRONIC REGISTER



# Installation Manual

# Table of Contents

Table of Contents	2	1-Stage Security Valve Installation	20
Receipt & Inspection	3	2-Stage Preset Valve Installation	21
Notice	3	Temperature Probe Installation	22
Introduction	4	Temperature Probe Installation Kits	23
System Specifications	4	Daisy Chain Communication	24
Dimensions	5	Printer Installation	25
682 Piston Meter Installation	6	Printer Installation Kits	26
700 Rotary Meter Installation	7	Printer Installation Kits (Continued)	27
Remote Meter Installation	8	Printer Installation Kits (Continued)	28
Remote Meter Mounting Dimensions	9	Power Off Time Relay installation	29
Grounding Strap Installation	10	Radio Modem Installation	30
Power On Time Relay Installation	11	Sierra Cellular Modem Installation	31
Direct Mount Pulsar Installation	12	Maestro Cellular Modem Installation	32
Test Pulsar Installation	13	Remote Display Installation	33
Pump Control Installation	14	1-Channel Communication Board Installation	34
Pump Speed Control Installation	14	1-Channel Differential Pressure (DP) Installation	35
Additive Injection Pump Installation	15	1-Channel Tank Level Monitor Installation	36
Electronic Air Eliminator — Float	16	8-Channel Tank Level & DP Installation	37
Electronic Air Eliminator — Vibronic	17	Typical Wiring Diagram	38
LPG 1-Stage Security Valve Installation	18	Software Version Upgrade Instructions	39
LPG 2-Stage Preset Valve Installation	19	Replacement Front Cover Computer Instructions	40
		Parts Schematic	41
		Warranty	42

## Warning Symbols



### CAUTION

Follow the warning instructions within the following information to avoid equipment failure, personal injury or death.



### TURN POWER OFF

Before performing any maintenance, be sure to turn system power off to avoid any potential electric spark



### FLAMMABLE

Flammable liquids and their vapors may cause a fire or explosion if ignited.



### EYE PROTECTION

Pressurized systems may cause hazardous leaks and spray that may be dangerous for your eyes. Always wear eye protection around pressurized systems and its hazardous liquids.



### INJURY

Wear gloves for protection from hazardous liquids that may cause irritation or burns.



### READ

Read and understand all related manuals thoroughly. The Engineering and OIM manuals will provide the knowledge for all systems, maintenance and operation procedures. If you have any questions, please consult the factory.

**WARNING** EXPLOSION HAZARD – DO NOT DISCONNECT EQUIPMENT WHILE THE CIRCUIT IS LIVE OR UNLESS THE AREA IS KNOWN TO BE FREE OF IGNITABLE CONCENTRATIONS

**WARNING** EXPLOSION HAZARD – SUBSTITUTION OF ANY COMPONENT MAY IMPAIR SUITABILITY FOR UL/cUL CLASS 1, DIVISION 2, GROUPS C AND D HAZARDOUS LOCATIONS.

## Receipt & Inspection

Upon receipt of register shipment, be sure to inspect the packaging and the register assembly for any damage before signing the receipt of the shipment. Notify the delivery company about possible damage and refuse receipt of the shipment.

Registers are individually boxed and are protected with static resistant packing material. Each package is identified with the register assembly part number, description and serial number. Verify the register model is the correct model, size, and configuration as ordered. Contact your distributor if there is any discrepancy or question.

Register assemblies should be handled with appropriate methods for the size and weight involved. Appropriate clothing and shoes need to be utilized. Transport the register package to the installation site with appropriate transportation methods, careful not to damage the register.

Be careful of any loose or protruding staples from the packaging, as they can be very sharp and may potentially cause injury.

If foam has been used to protect register, carefully remove top foam layer before attempting to remove register assembly from box. Foam packaging maybe formed around the register assembly making it difficult to remove. Do not lift the register assembly by wires or anything other than the metal body of the register. Do not insert objects or cables into the register unless stated. Removing register assembly from packaging without adhering to these warnings may cause serious injury to you and/or the register.

Appropriate precautions should be taken regarding any personal, environmental and material compatibility with the end use system.

## Notice

Total Control Systems (TCS) shall not be liable for technical or editorial errors in this manual or omissions from this manual. TCS makes no warranties, express or implied, including the implied warranties of merchantability and fitness for a particular purpose with respect to this manual and, in no event, shall TCS be liable for special or consequential damages including, but not limited to, loss of production, loss of profits, etc.

The contents of this publication are presented for informational purposes only, and while every effort has been made to ensure their accuracy, they are not to be construed as warranties or guarantees, expressed or implied, regarding the products or services described herein or their use or applicability. We reserve the right to modify or improve the designs or specifications of such products at any time.

TCS does not assume responsibility for the selection, use or maintenance of any product. Responsibility for proper selection, use and maintenance of any TCS product remains solely with the purchaser and end-user.

***All rights reserved. No part of this work may be reproduced or copied in any form or by any means – graphic, electronic or mechanical – without first receiving the written permission of Total Control Systems, Fort Wayne, Indiana USA.***

## Introduction

The TCS 3000 register is a fully integrated custody transfer flow computer that will control all vehicle delivery operations. The Open Software Architecture provides the option of a simple “Pump & Print” delivery or a custom measurement solution. The TCS 3000 features a 4.5”x 3.5” full color VGA display screen, multiple delivery screens and a backlit alpha-numeric keypad for the user interface. Available in flexible mounting configurations of 75 or 90 degree displays for meter mounting, and a remote mounting.

As an flow computer with open software architecture, there will always be a need to add features to the register as the industry applications evolve. Therefore please be reminded to contact the factory for periodic updates.

The TCS 3000 electronic register is a fully integrated flow computer that will control all delivery operations. The modular design and open software architecture provide you with a tailored system that is expandable for future needs. The TCS 3000 features a large easy view VGA screen, alpha-numeric keypad and open printer interface for simple “Pump and Print” deliveries. Software features offer complete flexibility of delivery screen information with preset, price/tax, customizable ticket format and password protection.

Optional GPS, Bluetooth, Wi-Fi and Cellular capability enables the TCS 3000 to improve your product security and ease access to your delivery data to reduce your operation costs. Many additional features are available (multiple product delivery, additive injection, density/temperature correction, multiple valve & pump control, etc.) to enhance your measurement solution.

This manual will help guide you with the setup confirmation and calibration of the register. Additional information will be provided for wiring instruction and auxiliary devices to integrate into the register.

## System Specifications

### ELECTRICAL

Power	12 — 24 VDC INPUT
Current	1.4 Amps
Solid State Relays	12/24 Vdc; Passive Solid State

### INTERNAL PULSER

Pulse Ratio	100:1 PPR; Quadrature
Power	5 Vdc
Hertz	0 — 5000 Hz

### EXTERNAL PULSE INPUT

Type	Single or Dual Channel (Quadrature)
Power	5 Vdc

### ENCLOSURE

Aluminum die cast with epoxy powder coat	
Ratings	UL/cUL Class 1, Division 2, Group C + D Hazardous Locations IP 66 / NEMA 4
Temperature Range	- 40 F to 158 F (-40 C to 70 C)
Connection Ports:	Ten (10) 1/2” NPT UL/cUL threaded connection ports Optional ten (10) M20 ATEX threaded connection ports
Calibration Seal	Optical switch, password and mechanical seal

The USB0 and USB1 ports are for maintenance only. To access these connectors, power to the unit must be disconnected and the area known to be free of ignitable gas or equivalent.

## COMMUNICATION

Four (4) RS 485 output, 2-wire half duplex, custom protocol; 9600 baud, 8 bit, no parity, 1 stop bit

One (1) RS 232 output, 9600 baud; 8 bit, no parity, 1 stop bit

## DIMENSIONS — INCHES (MILLIMETERS)

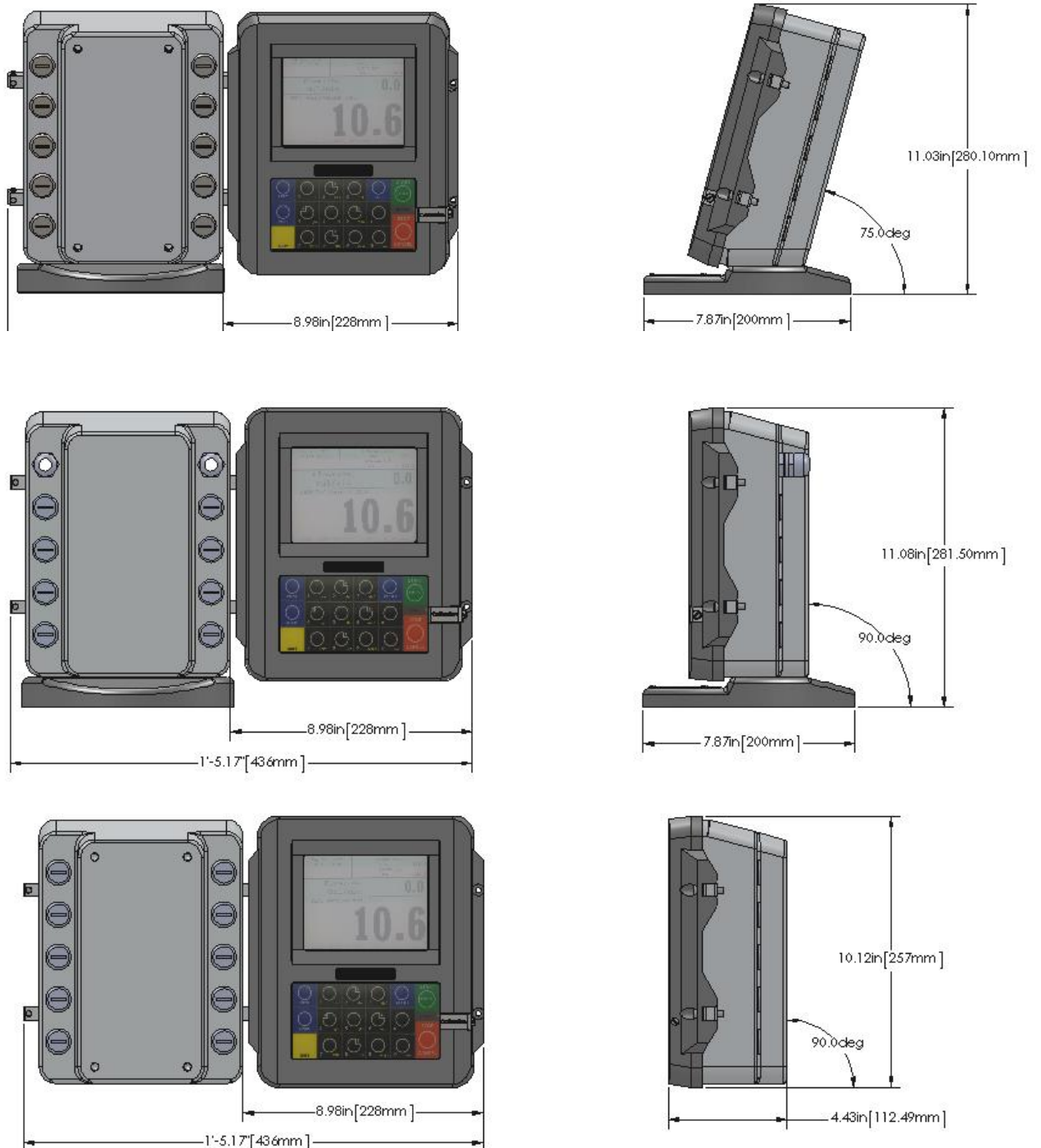

## Installation Procedure — TCS 682 Series Meter

Before beginning the installation of the TCS 3000 register, unpack the entire contents of the packaging in a safe location where you will not misplace any of the parts. Lay out the parts as they would be installed. This will ensure that you have all the correct parts for the installation. Verifying all the necessary parts were included in the shipment in advance will reduce downtime and avoid any wasted preparation work.

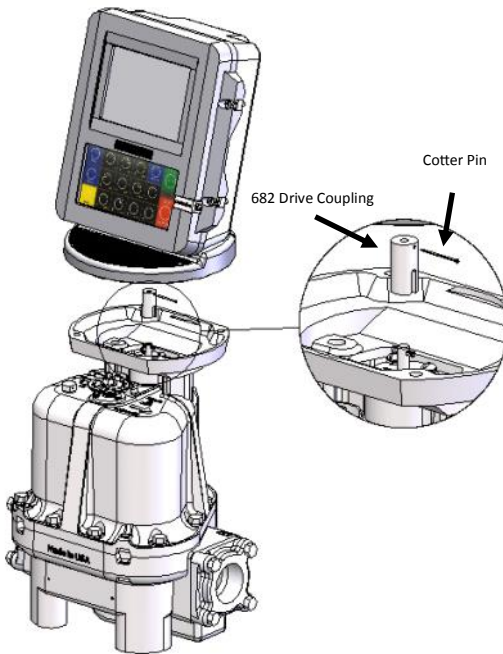

Item	Qty	TCS 300871 Metric	TCS 300971 NPT
Phillips Pan	6	TCS300137	TCS300137
Spring Washer	6	TCS300138	TCS300138
Terminal Cover	1	TCS300164	TCS300164
7.5 AMP Fuse	1	TCS300192	TCS300192
Fuse Holder	1	TCS300193	TCS300193
Cable Gland	4	TCS300249	TCS300133
USB Fem/Mini Male Cable	1	TCS300705	TCS300705
Resistor 1K OHM	2	TCS300753	TCS300753
1/4—28 X 3/4 Zinc Bolt	2	TCS68004	TCS68004
1/4—28 X 3/4 Drilled Bolt	2	TCS68004D	TCS68004D
Drive Coupling, 682	1	TCS600420	TCS600420
3/64 X 1 Cotter Pin	1	TCS790091	TCS790091

### Installation Procedure:

1. Remove and put aside the four mounting bolts and any mounting adaptor. Remove the existing mechanical register or electronic register, if applicable. Use a box or container to set old equipment and parts in.
2. Using the shaft specific to your installation, slide the Drive Shaft Coupling on the Pulser Shaft and align the holes. Once the holes are aligned insert the Cotter Pin and bend the pin ends back around the Drive Coupling.
3. Slide the Drive Coupling onto the Meter Drive Shaft.
4. Rotate the TCS 3000 register until the display is facing in the desired direction and check to see that the meter holes align with the holes at the base of the TCS 3000 register.
5. Secure the bolts.

## Installation Procedure — TCS 700 Series Meter

Before beginning the installation of the TCS 3000 register, unpack the entire contents of the packaging in a safe location where you will not misplace any of the parts. Lay out the parts as they would be installed on the truck. This will ensure that you have all the correct parts for the installation. Verifying all the necessary parts were included in the shipment in advance will reduce the truck downtime and avoid any wasted truck preparation work.



Item	Qty	TCS 300870 Metric	TCS 300970 NPT
Phillips Pan	6	TCS300137	TCS300137
Spring Washer	6	TCS300138	TCS300138
Terminal Cover	1	TCS300164	TCS300164
7.5 AMP Fuse	1	TCS300192	TCS300192
Fuse Holder	1	TCS300193	TCS300193
Cable Gland	4	TCS300244	TCS300133
O-Ring, Cable Gland	4	TCS300245	TCS300245
USB Fem/Mini Male Cable	1	TCS300705	TCS300705
Resistor 1K OHM	2	TCS300753	TCS300753
1/4—28X1 Zinc Bolt	2	TCS68013	TCS68013
1/4-28X1 Drilled Bolt	2	TCS68013D	TCS68013D
3/64 X 1 Cotter Pin	1	TCS790091	TCS790091
700 Meter Drive Coupling	1	TCS790092	TCS790092

### Installation Procedure:

1. Remove and put aside the four mounting bolts and any mounting adaptor. Remove the existing mechanical register or electronic register, if applicable. Use a box or container to set old equipment and parts in.
2. Remove adjuster dust cover plate from the front of the meter. Remove existing adjuster. Set adjuster dust cover aside in a box or container where it will not be misplaced. Screw the screws back into meter unit. Notice the type of vertical drive shaft in the meter.
3. Using the shaft specific to your installation, slide the Drive Coupling on the Pulser and align the holes. Once the holes are aligned insert the Cotter Pin and bend the pin ends back around the Drive Coupling.
4. Slide the Drive Coupling onto the Meter Drive Shaft.
5. Rotate the TCS 3000 register until the display is facing in the desired direction and check to see that the meter holes align with the holes at the base of the TCS 3000 register.
6. Secure the bolts.

## Installation Procedure — 3000 Remote Mount

Before beginning the installation of the TCS 3000 register, unpack the entire contents of the packaging in a safe location where you will not misplace any of the parts. Lay out the parts as they would be installed. This will ensure that you have all the correct parts for the installation. Verifying all the necessary parts were included in the shipment in advance will reduce downtime and avoid any wasted preparation work.

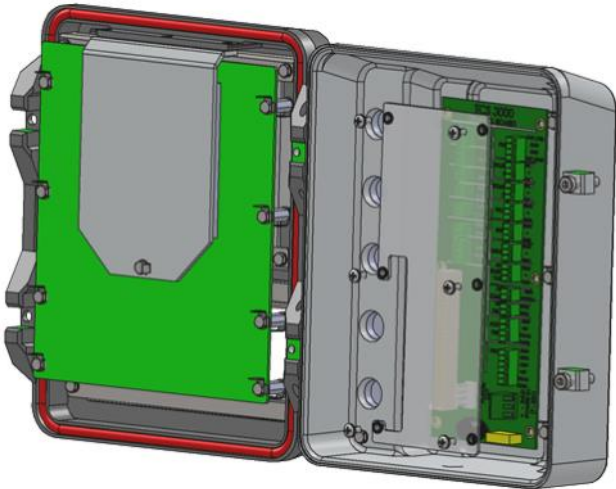

Item	Qty	TCS 300877 Metric	TCS 300977 NPT
Phillips Pan	6	TCS300137	TCS300137
Spring Washer	6	TCS300138	TCS300138
Terminal Cover	1	TCS300164	TCS300164
7.5 AMP Fuse	1	TCS300192	TCS300192
Fuse Holder	1	TCS300193	TCS300193
Cable Gland	4	TCS300249	TCS300133
O-Ring, Cable Gland	4	TCS300245	TCS300245
USB Fem/Mini Male Cable	1	TCS300705	TCS300705
Resistor 1K OHM	2	TCS300753	TCS300753

### Installation Procedure:

1. Use the Remote Mount Kit to mount the TCS3000 register in your desired location.
2. Follow the directions in the Direct Mount Pulser Manual (TCS900030) to install the Pulser on the meter.
3. Once the Pulser is wired, run the corresponding wire cable into the back of the TCS 3000 register.
4. Insert the pulser wiring through the cable gland. Wire the pulser into the correct pulser location on the terminal board. Leave a small amount of slack on the wiring. Be careful not to leave any bare exposed wiring.
5. Compress the cable gland on the TCS3000 register until it is snug on the pulser wire.



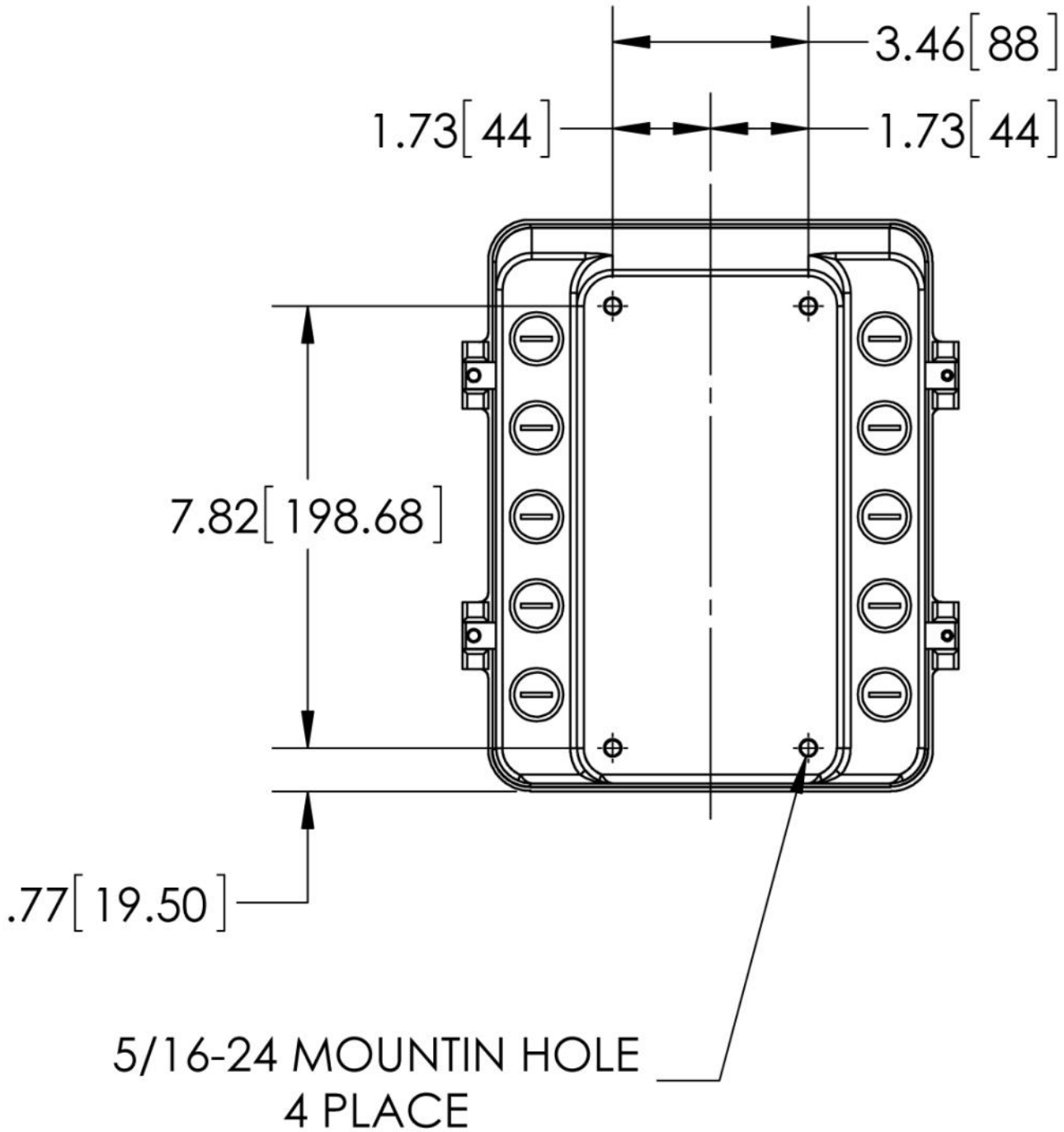

Dimensions—Inches (Millimeters)

## Installation Procedure — Grounding Strap

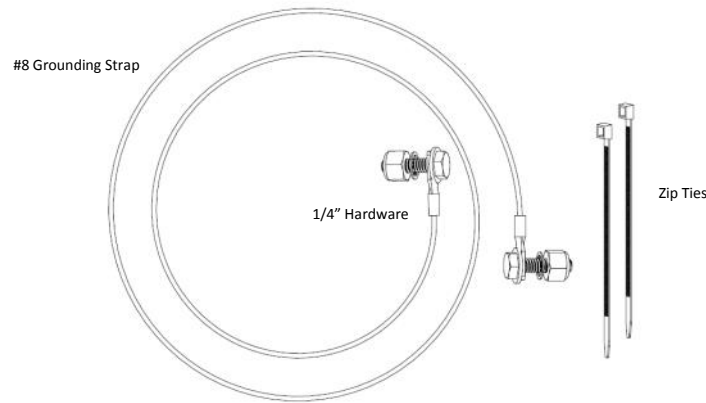

TCS 300597, Grounding Strap Kit

### Installation Procedure:

#### GROUNDING A TRUCK SEAT:

1. Identify any adjustable, shock absorbing seat in the truck cab. These seats will typically have pivot points, hinges, or other mechanical design features that make seat adjustments possible.
2. Find an existing screw or hole near the back of the seat frame, close to the cab floor. If a hole or screw does not already exist, drill a 3/8" hole in the seat frame.
3. Attach one end of the ground strap to the seat frame bracket using the lock washer, flat washer and nut provided.
4. Find an existing hole in the part of the seat frame attached to the seat cushion above any pivots and adjustments. If a hole or screw does not already exist, drill a 3/8" hole in the seat frame. Make sure that there are no interfering pivots, guides, or adjustment mechanisms that could interfere with the ground path between the seat cushion and the ground strap. *If the seat cushion has a wooden base, attach the strap lug to an existing screw from the metal bracket directly attached to the wood seat where the seat fabric is attached to the wood. There must be good contact between the seat fabric and the ground strap lug.*
5. Use the wire ties provided with the kit and tie off the strap so that it doesn't interfere with the movement of the seat and is clear of traffic areas in the cab.
6. Check the strap for a good ground connection. (see right)

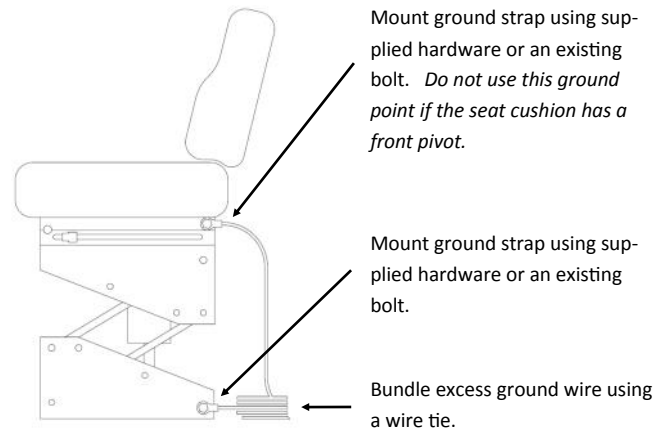

#### Checking for good ground connection along the ground strap:

1. Turn OFF all accessories, including the dome light, to prevent other currents from distorting the reading.
2. Take a multimeter and measure the resistance between the brackets the ground strap bolts are fastened to.
3. If the resistance is less than 3Ω, the system is grounded adequately. If the resistance is still greater than 3Ω, check for proper metal to metal contact on both ends of the grounding strap. Clean any paint, dirt, or oxidation that may block the grounding point. If the resistance remains above 3Ω, attach the ground strap to a different point and repeat the process until resistance is below 3Ω.



### Power On Timing Relay

When installing the TCS 3000 register on delivery tank trucks, it is recommended to use a timing relay for safe startup of the TCS 3000 registration. Install the TCS 300289 Power On Time Relay from the Accessory Ignition (ACC) to the TCS 3000 register for a selectable time (Seconds) open of power. This will allow the clean power to the TCS 3000 register during its boot up cycle and limit exposure to any significant current draw from charging glow plugs or a low power battery startup.

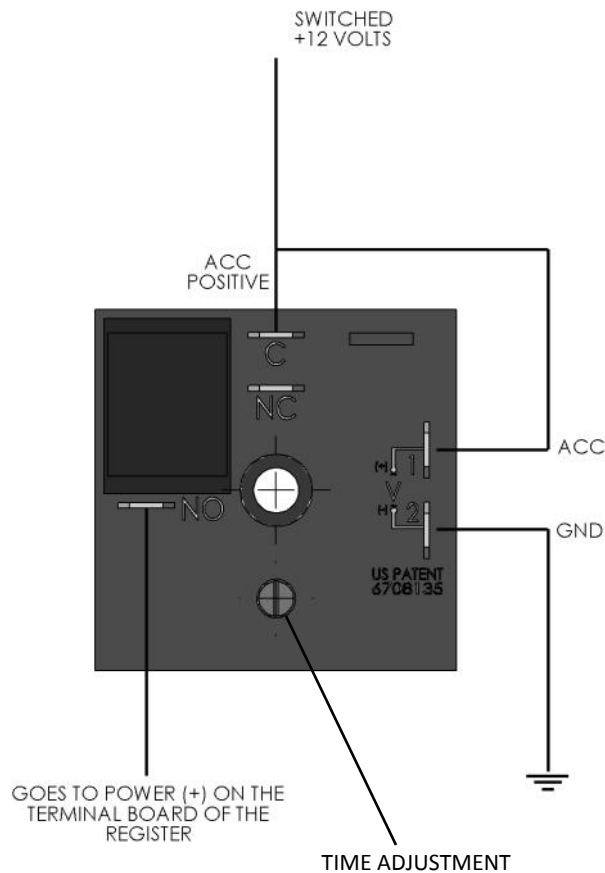

### Installation Procedure:

- 1) Wire GND to the Negative side of the Battery. NOTE: a minimum of a 18 gauge wire should be used.
- 2) Wire ACC (+) and (C) ACC Positive (on the relay), then jumper ACC Positive to the truck ACC (Ignition).
- 3) Wire N.O. to the (Positive) side of the Terminal Board in the TCS 3000 register.
- 4) Adjust the Time interval with a small Philips screw driver. Recommended minimum value is 45 seconds.

NOTE: If your wiring a Printer, it should be wired to the N.O. also. This will allow the printer to power up at the same time.

## Installation Procedure — Direct Mount Pulser

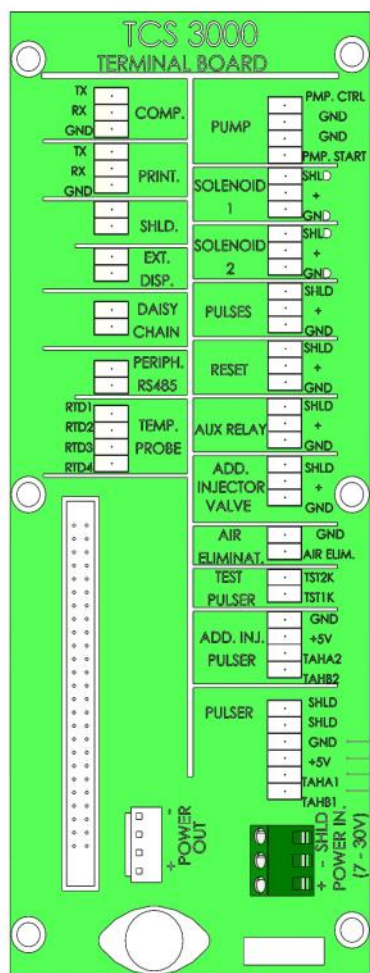
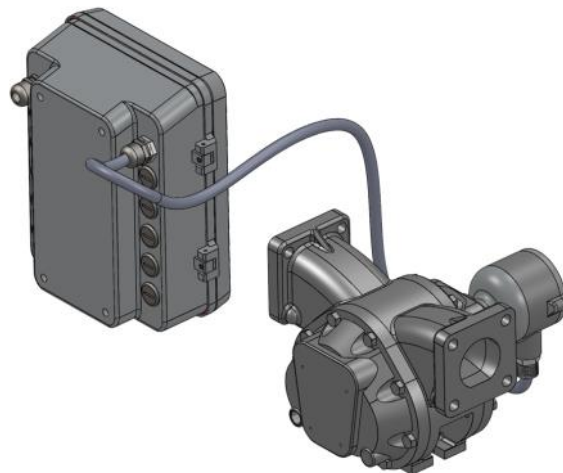
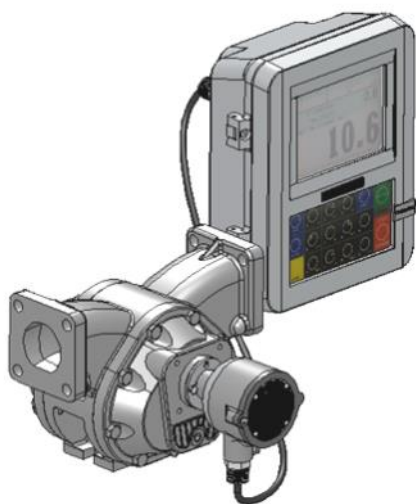

GND — GND  
 +5V — VIN  
 TAHA1 — CHA  
 TAHB1 — CHB

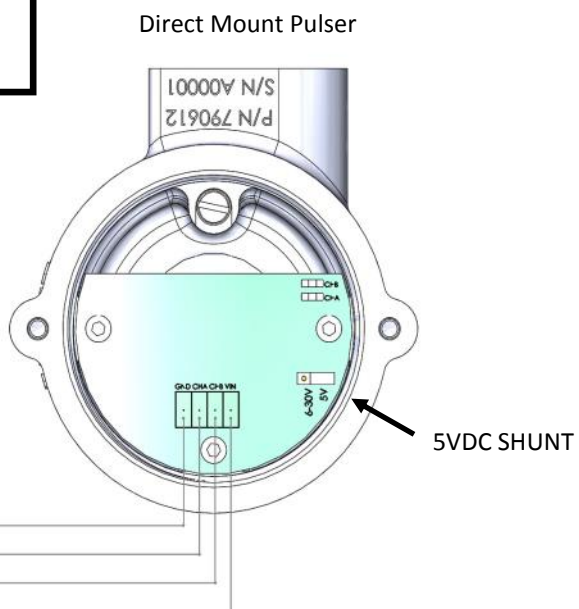

## Installation Procedure — Test Pulser



Prior to putting the liquid handling system into service, the distributor can utilize the TCS 3000 register TEST PULSER to verify that all Inputs/Outputs are working correctly. The Test Pulser will simulate an actual product delivery without having to pump product through the meter. Utilize the Test Pulser to check pump and additive injection pump outputs, air eliminator and exhaust valve operation, preset solenoid actuation, daisy chain communication for the modem and printers.

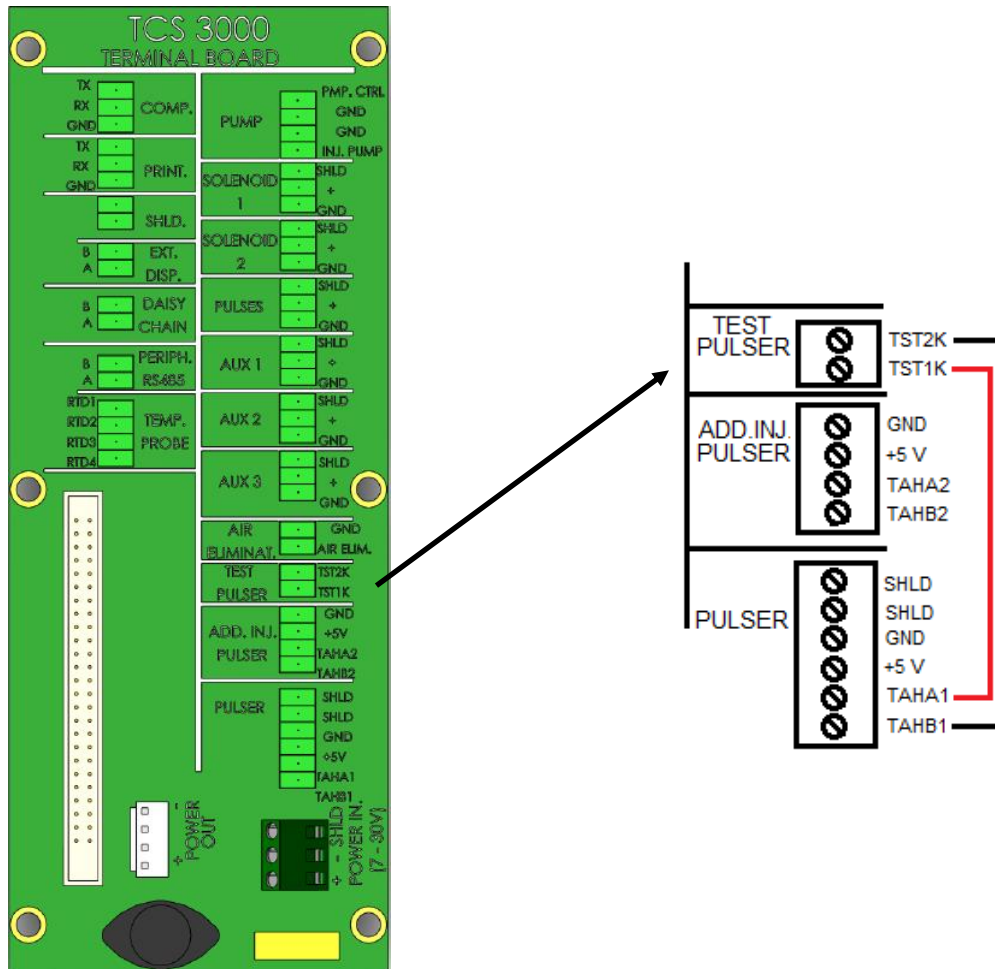

## Installation Procedure — Pump & Throttle



The Pump Control is utilized as a positive output signal for the entire delivery process. Providing security pump authorization and more accurate deliveries. Sometimes required to be used with onboard computer systems or programmable logic controllers (PLC).

### Installation Procedure:

1. Locate the Pump Control (PMP. CRL) position on the terminal board.
2. Screw the cable gland into the back of the TCS 3000 register and tighten into the housing.
3. Run the Pump Control to the onboard computer or programmable logic controller (PLC) wiring through the cable gland. Wire the air eliminator float into the correct location on the terminal board. Leave a small amount of slack on the wiring.
4. Compress the cable gland on the TCS3000 register until it is snug on the air eliminator float wiring.

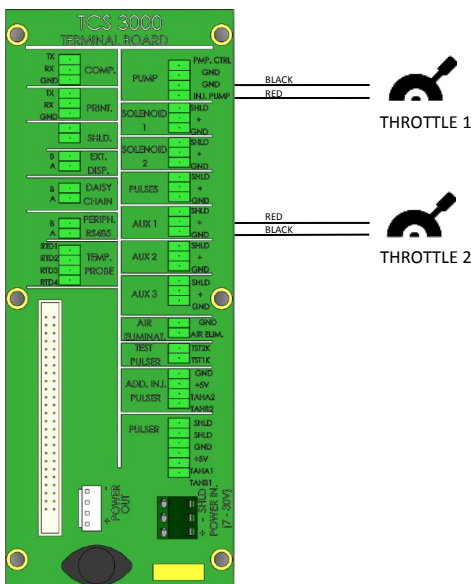
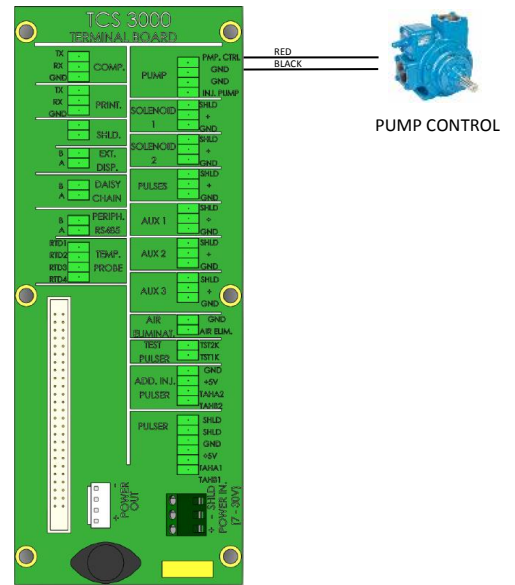

### Installation Procedure:

1. THROTTLE 1: Locate the Pump Starter (PMP START) port on terminal for Throttle 1 positive output signal based on Flow Rate. **WARNING:** Throttle 1 product selection will override the Additive Injection parameter if selected.
2. THROTTLE 2: Locate the Auxillary 1 (AUX 1) port on terminal for Throttle 2 positive output signal based on Flow Rate.
3. For both Throttle outputs, wire signal wire to (+) and ground to (GND).

## Installation Procedure — Additive Injection Pump



There are two selections for managing Additive Injection Pumps; External and Piston.

**EXTERNAL:** The External function for Additive Injection is to provide a positive output signal during the entire delivery process to manage an external additive injection pump. The source power voltage is what you will receive from the terminal named PMP. START.

**NOTE:** If using Throttle Control 1, this will deactivate the External additive injection pump.

**Additive Meter:** A single or dual channel additive flow meter can be wired into the ADD. INJ. PULSER terminal to independently measure additive volume during a flow rate. Calibrate Additive Meter within following PISTON additive selection, then switch back to External.

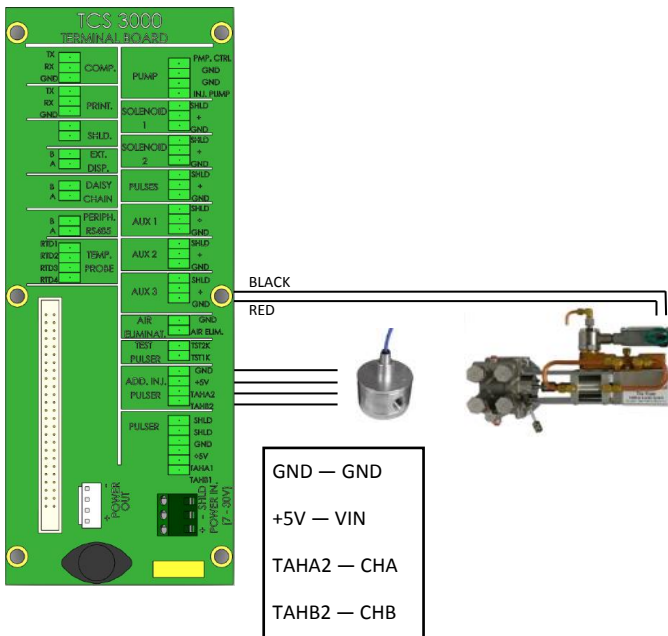
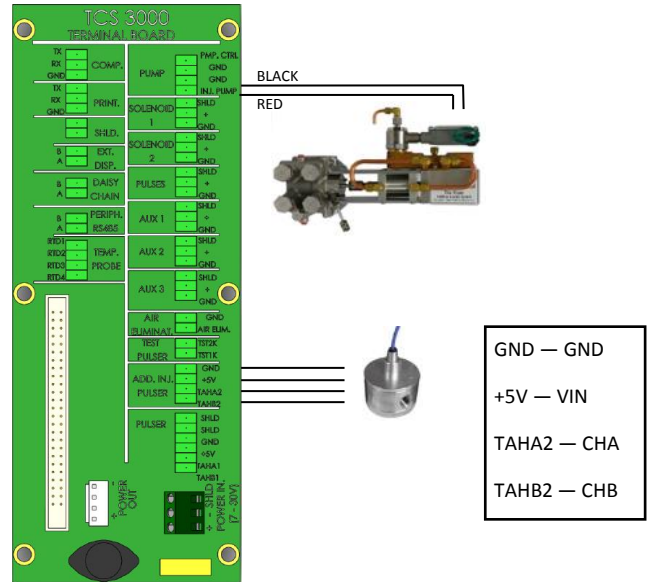

**PISTON:** The Piston function for Additive Injection is to provide calibrated positive output signals during the entire delivery process to actuate an external additive injection pump. The source power voltage is what you will receive from the terminal named ADD. INJECTOR VALVE.

**Additive Meter:** A single or dual channel additive flow meter can be wired into the ADD. INJ. PULSER terminal to independently measure additive volume during a flow rate.

**NOTE:** Additive Injection Pump and Valve terminals will not operate in Weights & Measures mode. Calibration for the PISTON additive injection pump and flow meter are required to be performed outside W&M Settings, then changed within W&M

## Installation Procedure — Float Electronic Air Eliminator



Air Eliminator Float Wiring

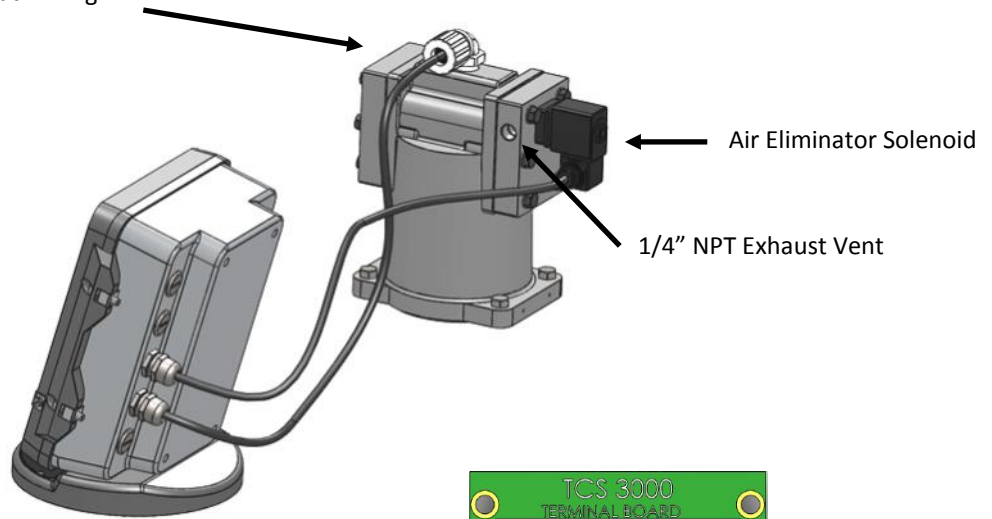

### Installation Procedure:

1. Locate the air eliminator float wiring on the metering system.
2. Install the cable gland into the back of the TCS 3000 register and tighten into the housing.
3. Run the air eliminator float wiring through the cable gland. Wire the air eliminator float into the Air Eliminator (AIR ELIMINAT.) terminal on the board. Leave a small amount of slack on the wiring.
4. Compress the cable gland on the TCS3000 register until it is snug on the air eliminator float wiring.
5. Locate the air eliminator solenoid wiring on the metering system.
6. Install the cable gland into the back of the TCS 3000 register and tighten into the housing.
7. Run the air eliminator solenoid wiring through the cable gland. Wire the air eliminator solenoid into the Auxiliary Relay 2 (AUX 2) on the terminal board. Leave a small amount of slack on the wiring.
8. Compress the cable gland on the TCS 3000 register until it is snug on the air eliminator solenoid wiring.  
NOTE: Do not run multiple cables through a single cable

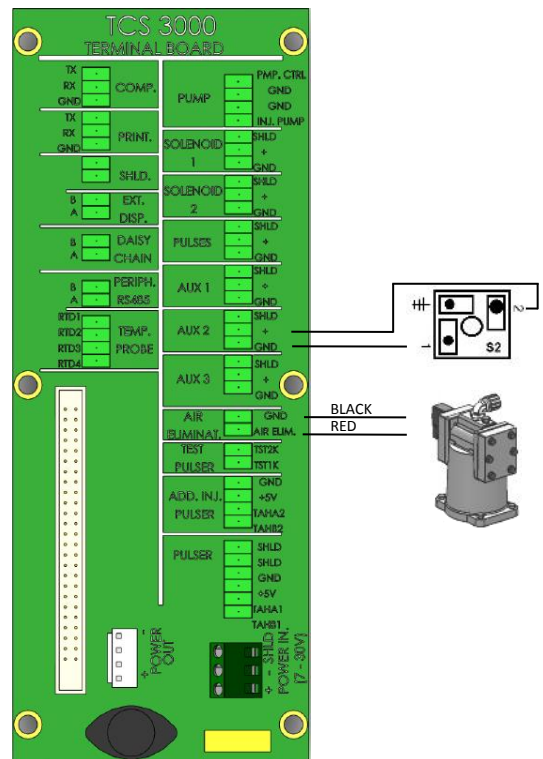



## Installation Procedure — Vibronic Electronic Air Eliminator

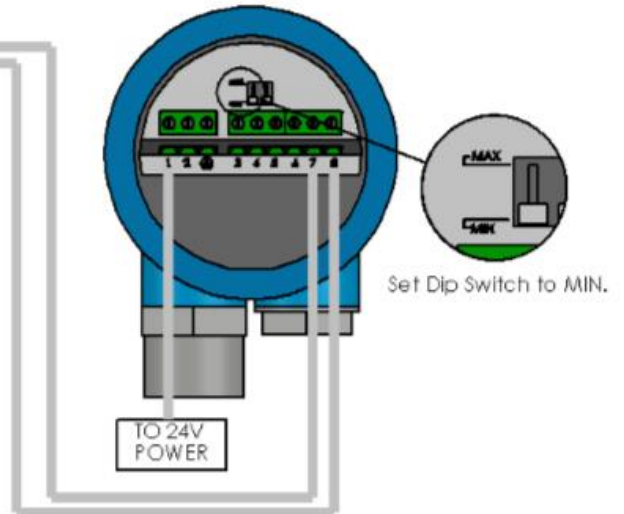
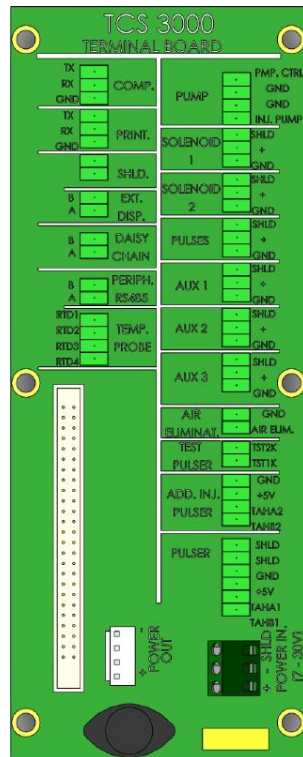
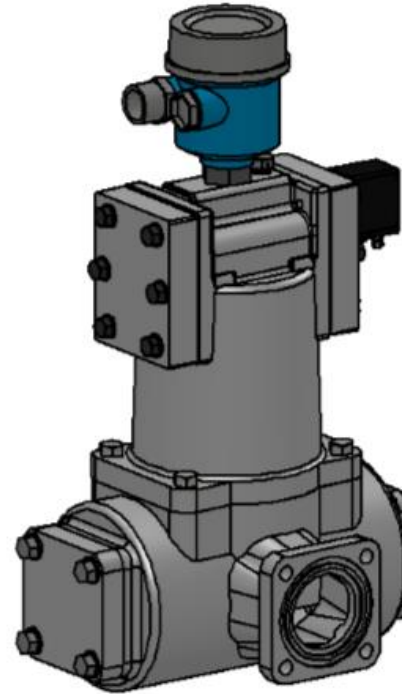
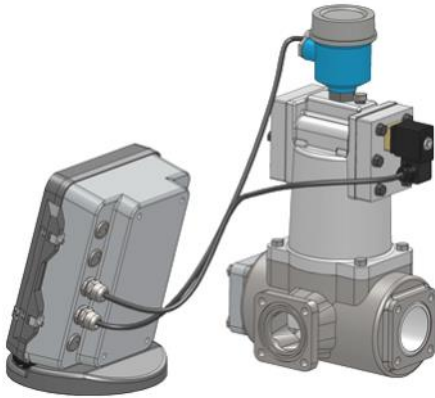

### Installation Procedure:

1. Connect Independent +24VDC to Terminal Block L1 in the Vibronic Sensor
2. Connect Terminal Block 7 to "GND" and Terminal Block 8 to "Air Elim." under Air Eliminator Section of the TCS 3000 register.
3. Set the Dip Switch on the Vibronic Sensor to the MIN Position.
4. Wire Air Eliminator Solenoid as normal.

## Installation Procedure — LPG 1-Stage Security Valve

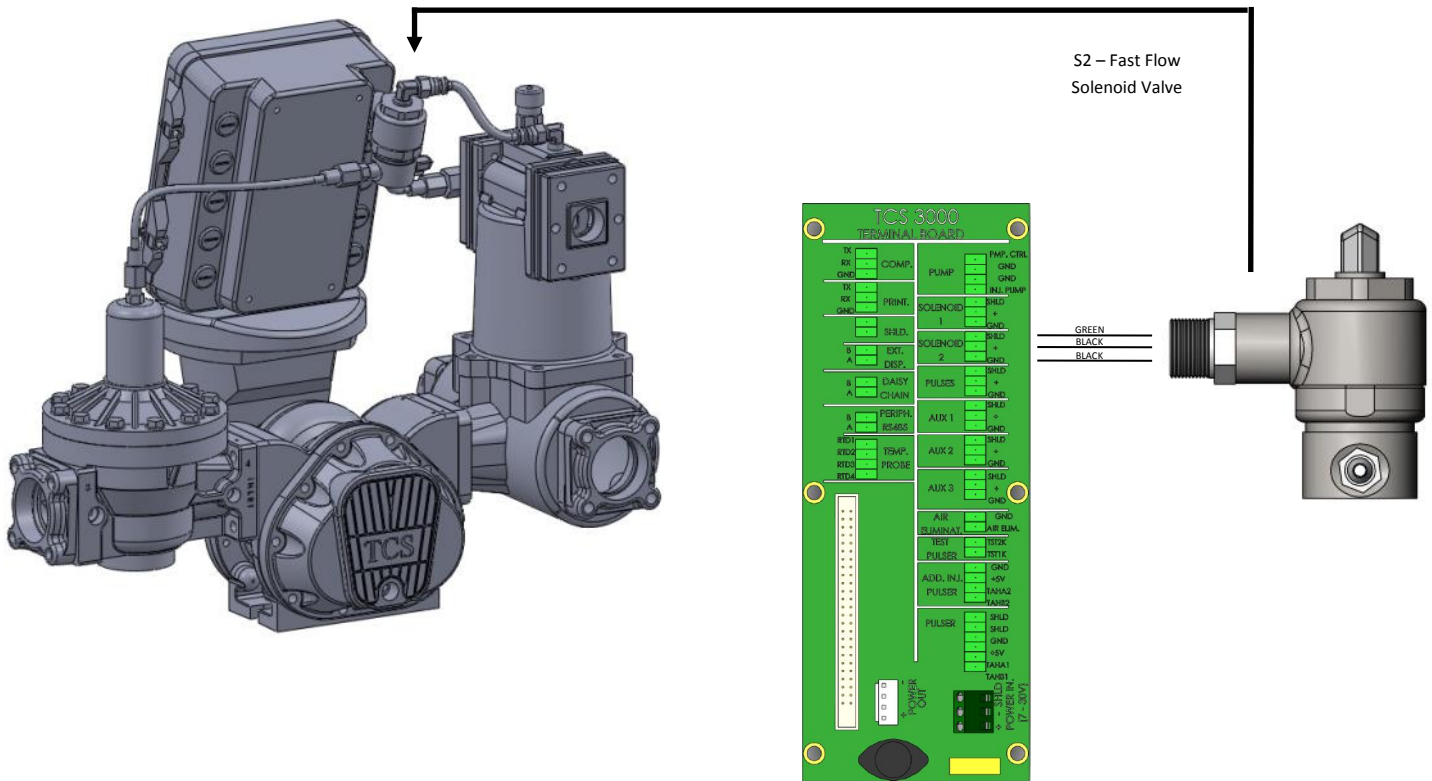

### Installation Procedure:

1. Using the bolts and gasket provided, install the 757 LPG valve on the outlet (downstream) side of the meter.
2. Follow the instructions provided with the valve for wiring the solenoid.
3. Mount the 3 Way Valve and threaded fitting directly to the TCS 3000 register and follow the instructions provided with the Valve.
 

**\*Note: Use Correct Thread Sealant\***
4. Once the solenoid is wired, run the corresponding wire as pictured using a minimum of 18 gauge shielded cable into the back of the TCS 3000 register. The 3 Way valve will be wired into Solenoid 2 on the terminal board.
5. TCS 3000 register product programming for Valve Type should be set to Single Stage.

**\*When Calibrating the Unit Set Up Valve Type as 1001\***

## Installation Procedure — LPG 2-Stage Preset Valve

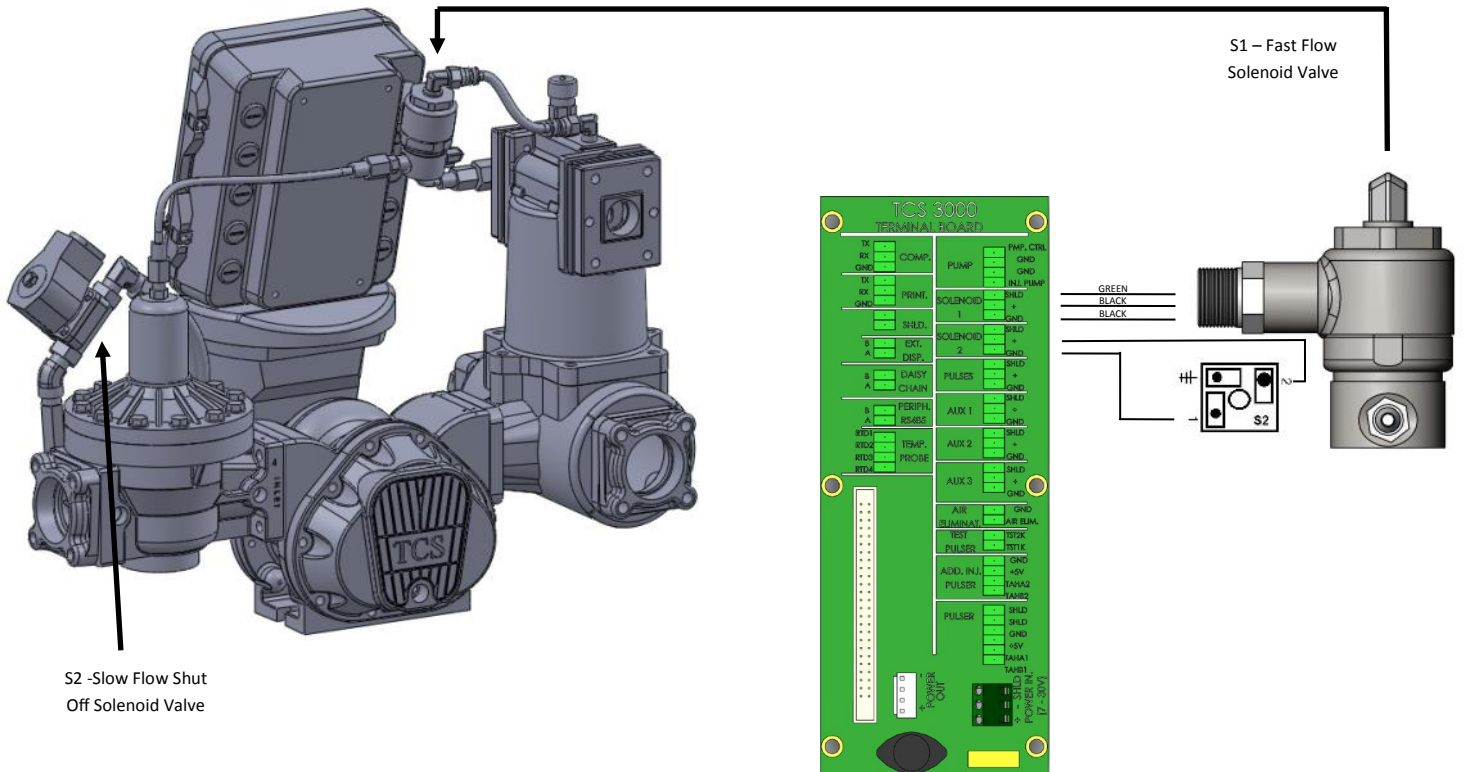

### Installation Procedure:

1. Using the bolts and gasket provided, install the 757 LPG valve on the outlet (downstream) side of the meter.
2. Follow the instructions provided with the valve for wiring the solenoid.
3. Mount the 3 Way Valve directly to the TCS3000 register and follow the instructions provided with the Valve

**\*Note: Use Correct Thread Sealant\***

4. Once the solenoid is wired, run the corresponding wire as pictured using a minimum of 18 gauge shielded cable into the back of the TCS 3000 register. The 3-Way Valve will be wired into Solenoid 1 (S1) on the terminal board and the Slow Flow Bypass Valve will be wired into Solenoid 2 (S2).
5. Insert the solenoid wiring into the cable gland. Wire the solenoid into the correct solenoid location on the terminal board. Leave a small amount of slack on the wiring.
6. Compress the cable gland on the TCS 3000 register until it is snug on the solenoid wire.
7. TCS 3000 register product programming for Valve Type should be set to Dual Stage.

**\*When Calibrating the Unit Set Up Valve Type as 1001\***

## Installation Procedure — 1-Stage Security Valve

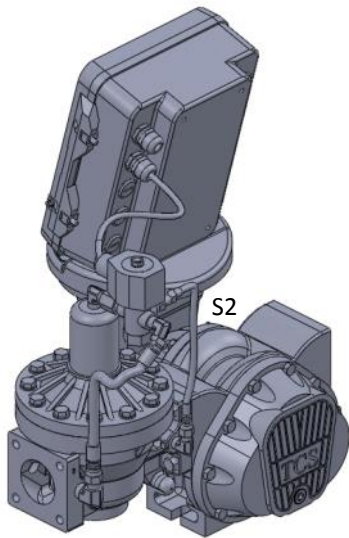

655-21 Diaphragm 2" Valve

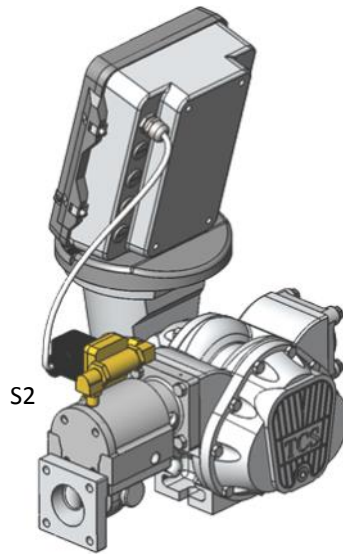

755-21 Piston 2" Valve

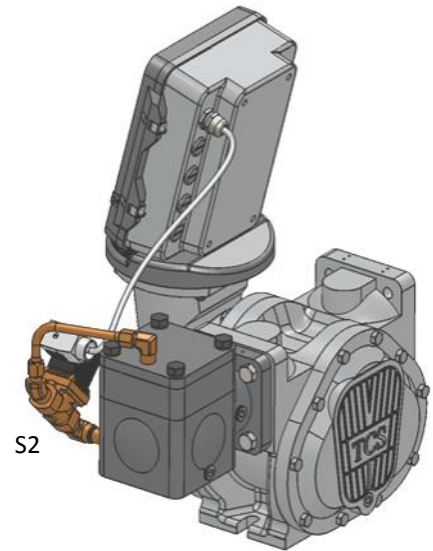

755-31 Diaphragm 3" Valve

### Installation Procedure:

1. Using the bolts and gasket provided, install the 655 Diaphragm or 755 Piston Valve on the outlet (downstream) side of the meter.
2. Wire the solenoid valve to Solenoid 2 (S2) for a Single Stage operation
3. Once the solenoid is wired, run the corresponding wire as pictured using a minimum of 18 gauge shielded cable into the back of the TCS 3000 register.
4. Insert the solenoid wiring into the cable gland. Wire the solenoid into the correct solenoid location on the terminal board. Leave a small amount of slack on the wiring.
5. Compress the cable gland on the TCS3000 register until it is snug on the solenoid wire.

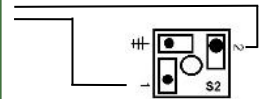
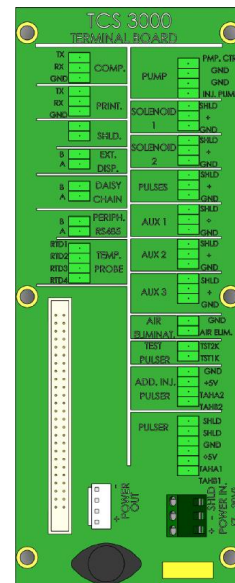

\*When Calibrating the Unit Set Up Valve Type as 1101\*

## Installation Procedure — 2-Stage Preset Valve

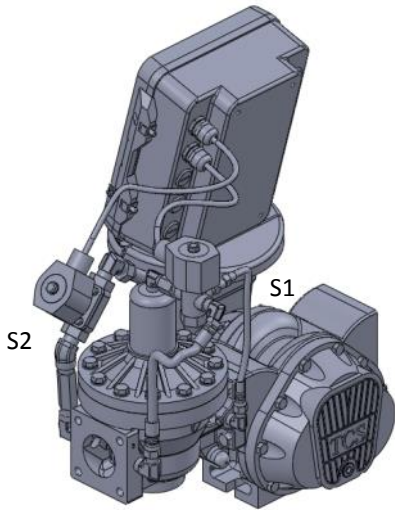

655-21 Diaphragm 2" Valve

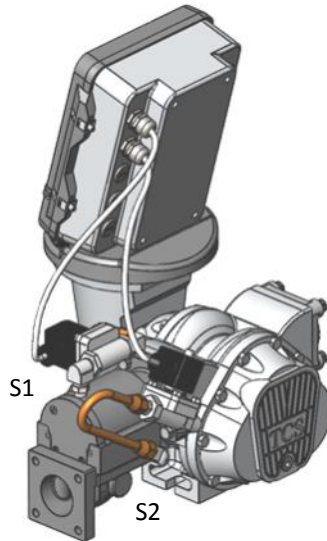

755-21 Piston 2" Valve

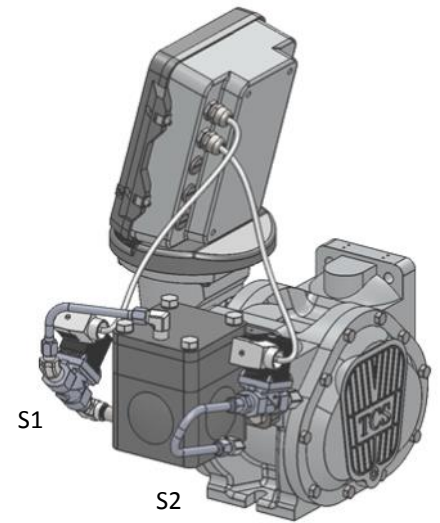

755-31 Diaphragm 3" Valve

### Installation Procedure:

1. Using the bolts and gasket provided, install the 655 Diaphragm or 755 Piston Valve on the outlet (downstream) side of the meter.
2. Wire the Fast Flow valve to Solenoid 1 (S1) and the Slow Flow Shut Off valve to Solenoid 2 (S2) for a 2-stage preset operation.
3. Once the solenoids are wired, run the corresponding wire as pictured using a minimum of 18 gauge shielded cable into the back of the TCS 3000 register.
4. Insert the solenoid wiring into the cable gland. Wire the solenoid into the correct solenoid location on the terminal board. Leave a small amount of slack on the wiring.
5. Compress the cable gland on the TCS3000 register until it is snug on the solenoid wire.

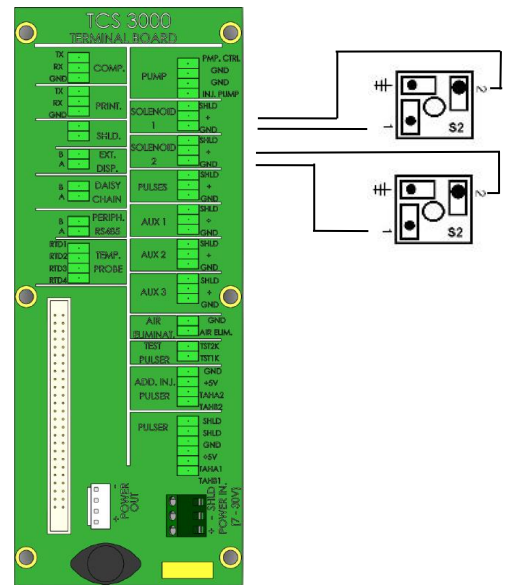

\*When Calibrating the Unit Set Up Valve Type as 1101\*

## Installation Procedure — Temperature Probe

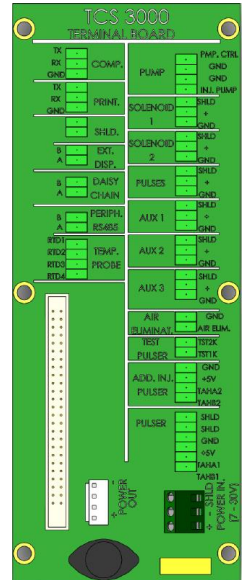
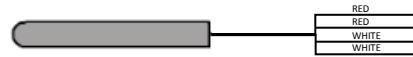
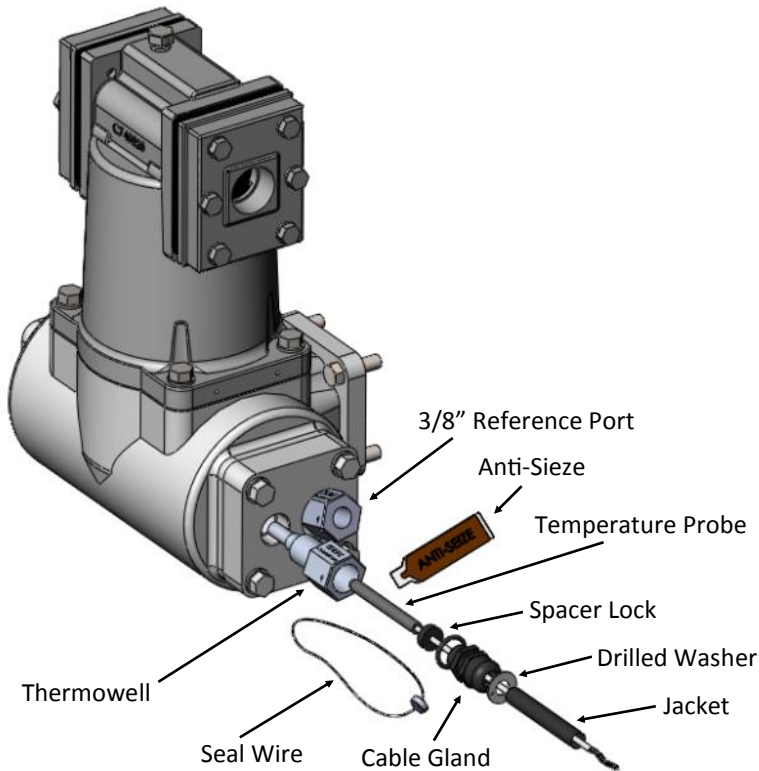

### Installation Procedure:

1. Locate the thermowell in the metering system.
2. Slide the temperature probe jacket over the temperature probe wire until it covers the entire wire.
3. Screw the cable gland into the thermowell and tighten. Squeeze the Copper Anti-Seize on the metal tip of the temperature probe.
4. Slide the temperature probe into the thermowell. Compress the cable gland down onto the temperature probe.
5. Screw the cable gland into the back of the TCS3000 register and tighten.
6. Insert the temperature probe wiring into the cable gland. Wire the Temp. Probe into the Temp Probe location on the terminal board. Leave a small amount of slack on the wiring.
7. Compress the cable gland on the TCS3000 register until it is snug on the temperature probe wire.
8. Run the temperature probe wiring to the back of the TCS 3000 register. Insert the wiring into the third cable gland from the top of the register as in the illustration above.
9. Leave slack in the temperature probe wiring and tighten the cable gland down on the temperature probe. If needed the probe wire may be trimmed of excess wire before tightening down the cable gland.
10. Wire the probe into the TCS 3000 register as pictured.

## Installation Procedure — Temperature Probe Kit



TCS 3000 RTD Probe/Aluminum Thermowell Kit

Item	Qty	TCS 300811 NPT
Cable Gland, 1/2 NPT UL	1	TCS 300133
O-Ring, 1/2 NPT Gland	1	TCS 300255
4 Wire 100 Ω Temperature Probe	1	TCS 300701
Temperature Probe Jacket	1	TCS 300702
Caplug T6X	1	TCS 300719
Copper Antiseize 2 Gram	1	TCS 300749
Thermowell 1/2" NPT Aluminum	1	TCS 740300
Thermowell 3/8" NPT Aluminum	1	TCS 740305
Nylon Spacer Lock	1	TCS 740302
Drilled 3/8" SS Washer	1	TCS 740303

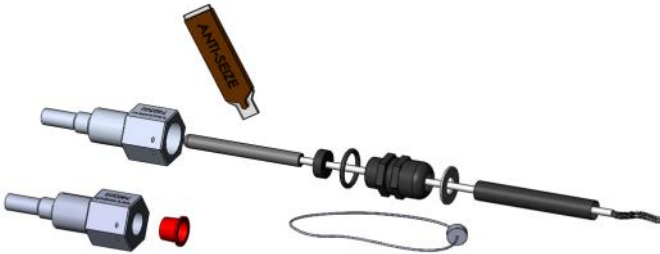

TCS 3000 RTD Probe/SS Thermowell Kit

Item	Qty	TCS 300815 NPT
Cable Gland, 1/2 NPT UL	1	TCS 300133
O-Ring, 1/2 NPT Gland	1	TCS 300255
4 Wire 100 Ω Temperature Probe	1	TCS 300701
Temperature Probe Jacket	1	TCS 300702
Caplug T6X	1	TCS 300719
Copper Antiseize 2 Gram	1	TCS 300749
Thermowell 1/2" Stainless Steel	1	TCS 740400
Thermowell 3/8" Stainless Steel	1	TCS 740405
Nylon Spacer Lock	1	TCS 740302
Drilled 3/8" SS Washer	1	TCS 740303

## Installation Procedure — Daisy Chain Communication



### Daisy Chain:

Daisy Chain is used for linking multiple registers together to use one printer or modem to link multiple registers to the database.

To Daisy Chain the Registers use a two wire 22 gauge shielded cable. Nominate one Register to be the Host.

Once you've chosen which Register will be the Host the other Registers will be considered the clients. Run the 22 gauge wire from slot A and B of DAISY CHAIN on the Host Unit to slot A and B of DAISY CHAIN on the Client Unit.

To tie the Client to the next Client unit on the Daisy Chain, run the 22 gauge wire from slot A and B of DAISY CHAIN to slot A and B of the next client's DAISY CHAIN.

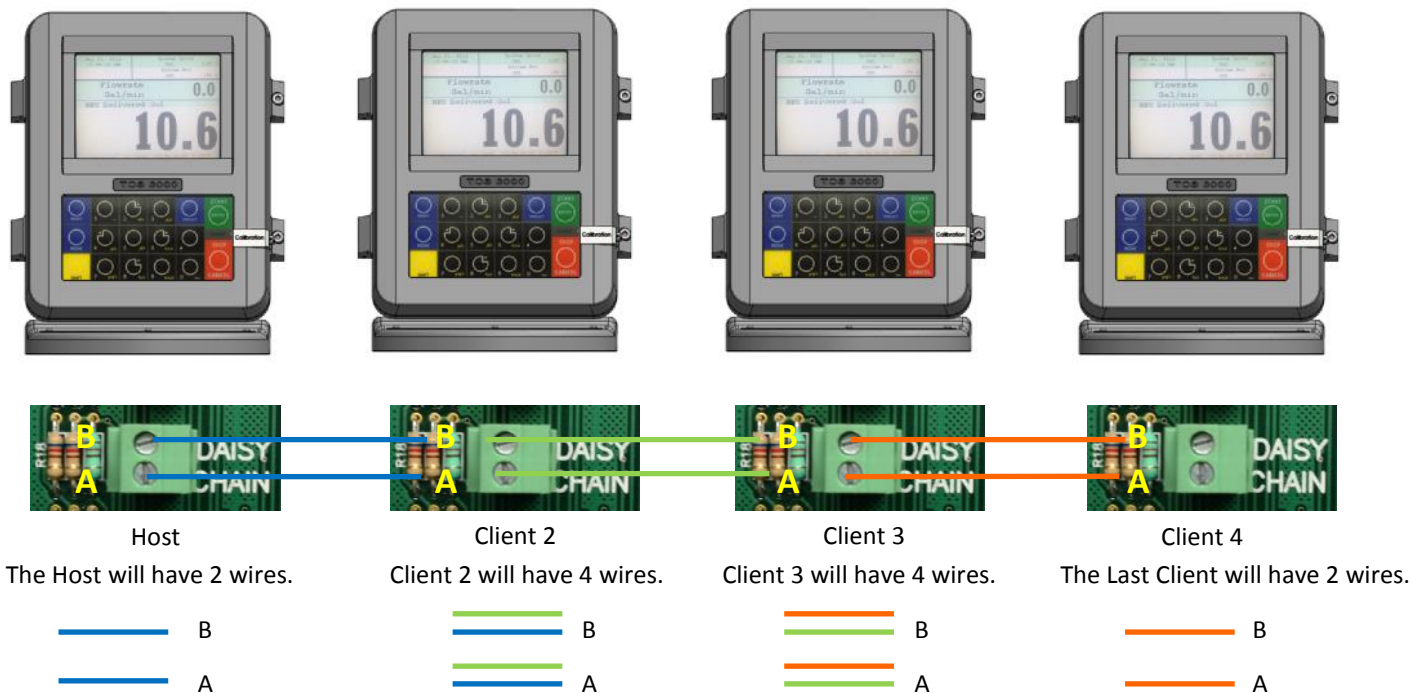

Continue to Daisy Chain until you have tied the chain together, alternating slots on the Daisy Chain until you've reached the end of the chain. The Host and the last Client on the chain will be the only two registers on the chain to have a two wire connection.



## Installation Procedure — Printer

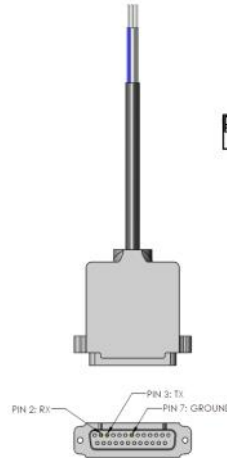

PIN 3	WHITE
PIN 2	BLUE
PIN 7	BLACK

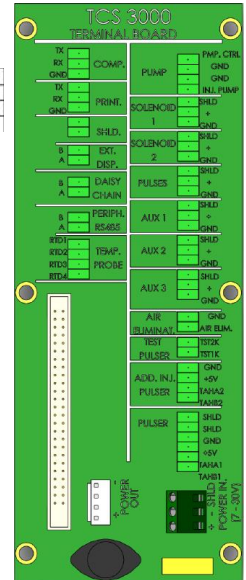

### Installation Procedure:

1. Find a suitable location for the printer appropriate to your application.
2. Secure the printer in place with the Velcro strip provided.
3. Wire the power and communication cables into the back of the printer.
4. Run the communication cable to the back of the TCS3000.
5. Screw the cable gland into the back of the TCS3000 and tighten.
6. Insert the printer communication cable into the cable gland and wire into the correct location on the terminal board.
7. Compress the cable gland on the TCS3000 until it is snug on the printer communication cable.

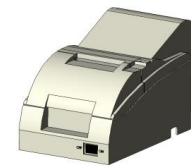
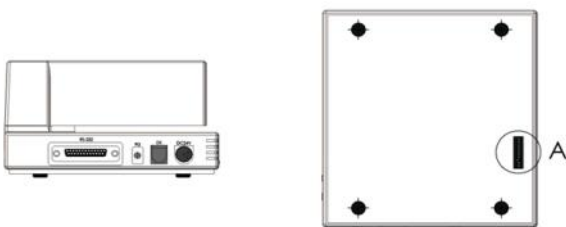

Epson Slip Printer  
The DIP Switch on Pole 3 must be set to ON.

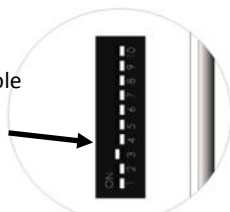

DETAIL A

The DIP Switch on Pole 3 must be set to ON.

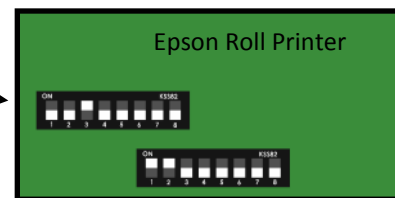

DETAIL B

**NOTE: Once DIP Switch 3 has been moved to position ON; You must cycle power for the Parameter to retain.**

## TCS 3000 Epson Slip 12 VDC Kit



Item	Qty	TCS 300851 Metric	TCS 300951 NPT
Cable Gland	1	TCS 300244	TCS 300254
O-Ring, Gland	1	TCS 300245	TCS 300255
12VDC Epson Printer Power	1	TCS 300712	TCS 300712
3 Wire Printer Comm Cable	1	TCS 300714	TCS 300714
Velcro 4" X 5"	1	TCS 300721	TCS 300721
Epson Printer	1	TEL TMU295-011	TEL TMU295-011
Wehof Order Form	1	TCS WEHOF	TCS WEHOF

## TCS 3000 Epson Slip 24 VDC Print Kit



Item	Qty	TCS 300885 Metric	TCS 300985 NPT
Cable Gland	1	TCS 300244	TCS 300254
O-Ring, Gland	1	TCS 300245	TCS 300255
3 Wire Printer Comm Cable	1	TCS 300714	TCS 300714
Velcro 4" X 5"	1	TCS 300721	TCS 300721
Epson Printer	1	TEL TMU295-011	TEL TMU295-011
24 VDC Epson Printer Power	1	TCS 300772	TCS 300772
Wehof Order Form	1	TCS WEHOF	TCS WEHOF

## TCS 3000 Epson Slip Print 110V Kit



Item	Qty	TCS 300869 Metric	TCS 300969 NPT
Cable Gland	1	TCS 300244	TCS 300254
O-Ring, Gland	1	TCS 300245	TCS 300255
3 Wire Printer Comm. Cable	1	TCS 300714	TCS 300714
Velcro 4" X 5"	1	TCS 300721	TCS 300721
Epson Printer	1	TEL TMU295-011	TEL TMU295-011
AC Power Supply w Cord	1	TEL TPS-180	TEL TPS-180
Wehof Order Form	1	TCS WEHOF	TCS WEHOF

## TCS 3000 Epson Roll 12 VDC Kit



Item	Qty	TCS 300850 Metric	TCS 300950 NPT
Cable Gland	1	TCS 300244	TCS 300254
O-Ring, Gland	1	TCS 300245	TCS 300255
12 VDC Epson Printer Power	1	TCS 300712	TCS 300712
3 Wire Printer Comm. Cable	1	TCS 300714	TCS 300714
Velcro 4" X 5"	1	TCS 300721	TCS 300721
Roll Printer	1	TEL TMU220A103	TEL TMU220A103
Wehof Order Form	1	TCS WEHOF	TCS WEHOF

## TCS 3000 Epson Roll 24 VDC Print Kit



Item	Qty	TCS 300884 Metric	TCS 300984 NPT
Cable Gland	1	TCS 300244	TCS 300254
O-Ring, Gland	1	TCS 300245	TCS 300255
3 Wire Printer Comm Cable	1	TCS 300714	TCS 300714
Velcro 4" X 5"	1	TCS 300721	TCS 300721
24 VDC Epson Printer Power	1	TCS 300772	TCS 300772
Roll Printer	1	TEL TMU220A103	TEL TMU220A103
Wehof Order Form	1	TCS WEHOF	TCS WEHOF

## TCS 3000 Epson Roll Print 110V Kit

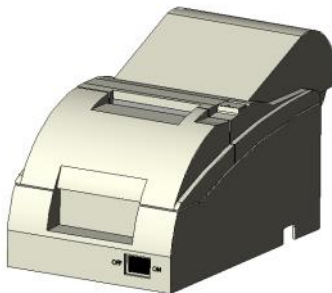

Item	Qty	TCS 300886 Metric	TCS 300986 NPT
Cable Gland	1	TCS 300244	TCS 300254
O-Ring, Gland	1	TCS 300245	TCS 300255
3 Wire Printer Comm Cable	1	TCS 300714	TCS 300714
Velcro 4" X 5"	1	TCS 300721	TCS 300721
Roll Printer	1	TEL TMU220A103	TEL TMU220A103
110VAC Epson Printer Power	1	TCS 300773	TCS 300773
Wehof Order Form	1	TCS WEHOF	TCS WEHOF

## TCS 3000 Printek Bluetooth Kit



Item	Qty	TCS 300852 Metric	TCS 300952 NPT
Cable Gland	1	TCS 300244	TCS 300254
O-Ring, Gland	1	TCS 300245	TCS 300255
Printek Printer	1	TCS 300706	TCS 300706
Velcro 4" X 5"	1	TCS 300721	TCS 300721
Bluetooth Modem	1	TCS 300722	TCS 300722
Printek Charger	1	TCS 300727	TCS 300727
Printek Blue Tooth Docking	1	TCS 300728	TCS 300728
Wehof Order Form	1	TCS WEHOF	TCS WEHOF

## TCS 3000 Citizen Bluetooth Kit



Item	Qty	TCS 300854 Metric	TCS 300954 NPT
Cable Gland	1	TCS 300244	TCS 300254
O-Ring, Gland	1	TCS 300245	TCS 300255
* Velcro 4" X 5"	1	TCS 300721	TCS 300721
Bluetooth Modem	1	TCS 300722	TCS 300722
Citizen Bluetooth Print	1	TCS 300723	TCS 300723
DC Truck Adapter/Citize	1	TCS 300724	TCS 300724
Wehof Order Form	1	TCS WEHOF	TCS WEHOF

\*Bluetooth Modem will not pair with other devices, unless TCS Programs the device at the Factory\*

## Installation Procedure — Time Off Relay



### Power Off Timing Relay

When installing the TCS 3000 registration on delivery tank trucks with Cellular Modems, it is recommended to provide a timing relay for the power off of the modem and register to completely transmit all delivery records. Install the Power Off Time Relay from the Accessory Switch (ACC) to the TCS 3000 register for a selectable time (Seconds) open of power.

Item	TCS Part No.
Time-Off Relay; 12VDC	TCS 300785
Time-Off Relay; 24VDC	TCS300786

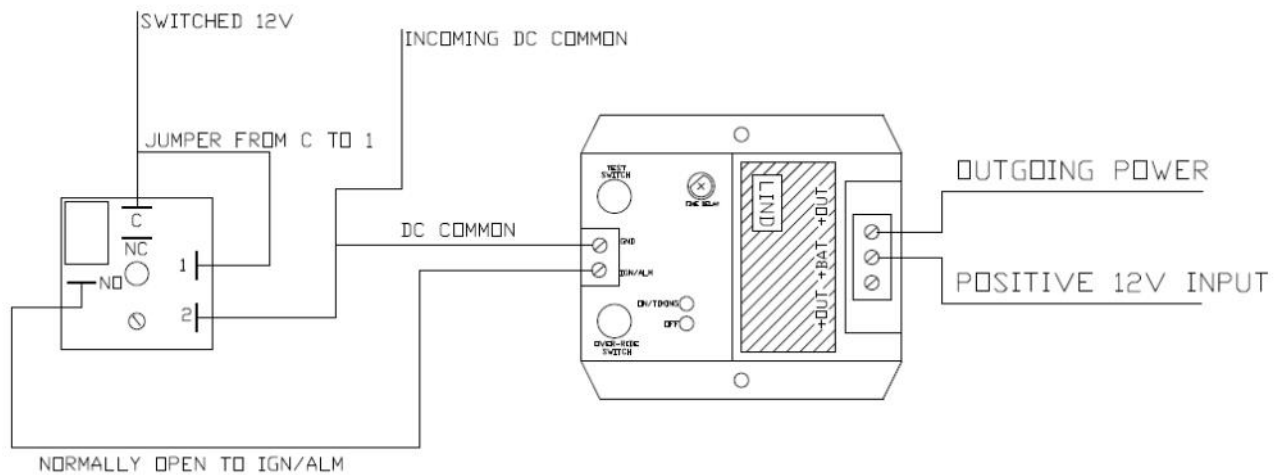

## Installation Procedure — 900MHz Radio Transmitter



### Installation Procedure

1. Wire the 9DB Pin Communication Cable to the Computer (COMP.) port of the TCS 3000 register terminal board.
2. Radio modems can be powered within the TCS 3000 register, via the Power Input.
3. Antenna must be connected to cellular modem for there to be any activity.

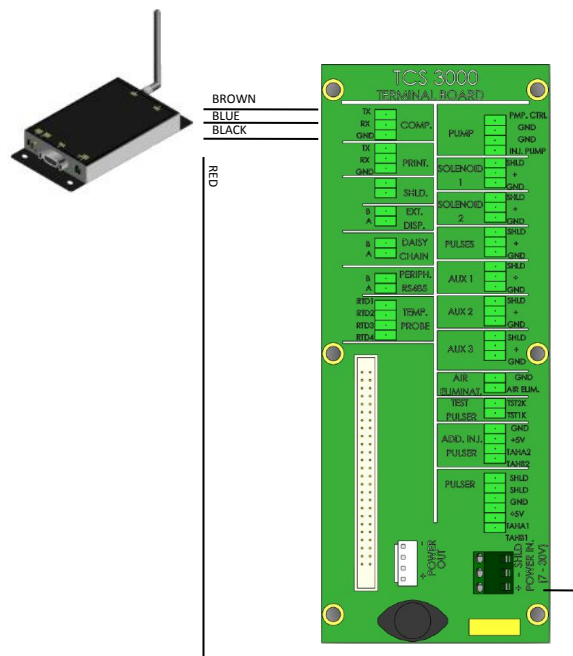

To make sure proper power and communication is achieved with your cellular modem, the DIP Switch Settings and LED operation will be illustrated as below:

#### DIP Switch Settings

- 1 = ON
- 2 = OFF
- 3 = OFF
- 4 = OFF
- 5 = ON
- 6 = OFF

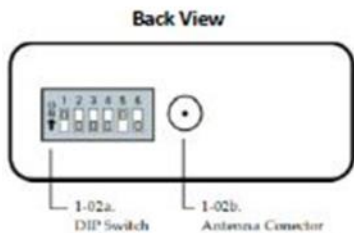

#### RSSI LEDs

(Green LED) indicates the amount of fade margin present in an active wireless link. Fade margin is defined as the difference between the incoming signal strength and the modem's receiver sensitivity.

- 3 LEDs ON = Very Strong Signal (> 30 dB fade Margin)
- 2 LEDs ON = Strong Signal (> 20 dB Fade Margin)
- 1 LED ON = Moderate Signal (> 10 dB Fade Margin)
- 0 LED ON = Weak Signal (< 10 dB Fade Margin)

Yellow light (Top) = DATA FROM OFFICE

Green light (Middle) = DATA TO OFFICE

Red light (Bottom) = POWER

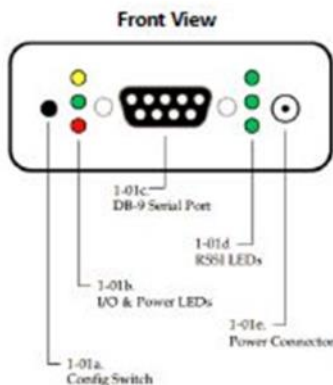

## Installation Procedure — Sierra Cellular Modem



### Installation Procedure

1. Wire the 9DB Pin Communication Cable to the Computer (COMP.) port of the TCS 3000 register terminal board.
2. Cellular modems come with their own Power Cable & Plug. The Red & White wire must be wired to the External Power Source (accessory switch) together. Ground to Battery ground.
3. Antenna must be connected to cellular modem for there to be any activity.
4. Cellular modems will be required to have proper programming prior to use.

To make sure proper power and communication is achieved with your cellular modem, the LED operation will be illustrated as below:

- Off - No activity
- Green - Full function
- Yellow - Limited Function
- Red - Not functional.

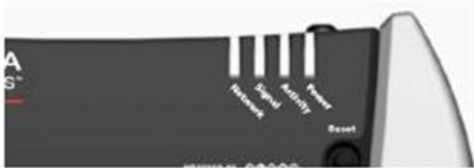

- **Network:**
  - Green - On the network
  - Flashing Green - Roaming
  - Yellow - Found service, attempting to connect
  - Flashing Yellow - Link down
  - Red - No data connection available.
- **Signal** - Light shows the strength of the signal and may be nearly solid (strong signal) or flashing (weaker signal). A slow flash indicates a very weak signal.
- **Activity** - Pulse green on packet transmit/receive on radio link.
- **Power:**
  - Off - No power (or above 36V or below 7.5V)
  - Red - System not operational
  - Green - Normal operation
  - Green, Occasional Yellow - GPS Lock
  - Yellow - Low power mode or system booting.

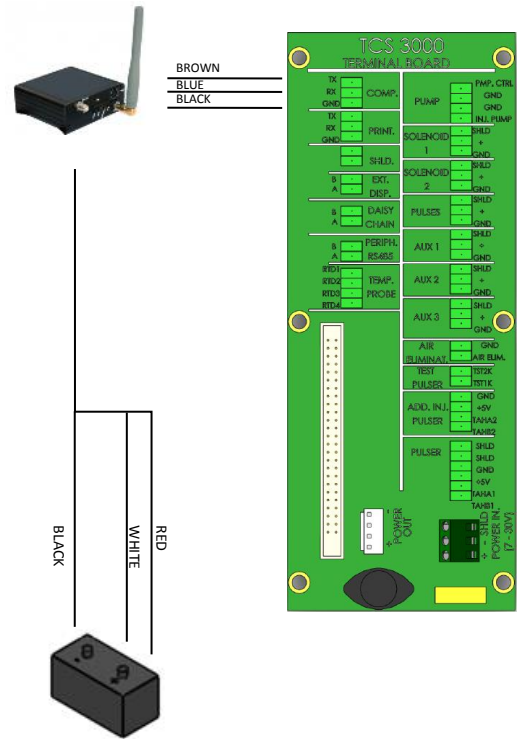

EXTERNAL POWER SOURCE

### 4-Pin Power Connector

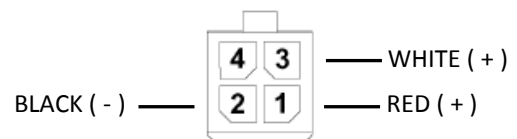

## Installation Procedure — Maestro Cellular Modem



### Installation Procedure

1. Wire the 15DB Pin Communication Cable to the Computer (COMP.) port of the TCS 3000 register terminal board.
2. Cellular modems come with a Power Cable & Plug. The Green wire must be wired to the External Power Source (accessory switch) together. The White wire must be wired to Battery ground.
3. Antenna must be connected to cellular modem for there to be any activity.
4. Cellular modems will be required to have proper programming prior to use.

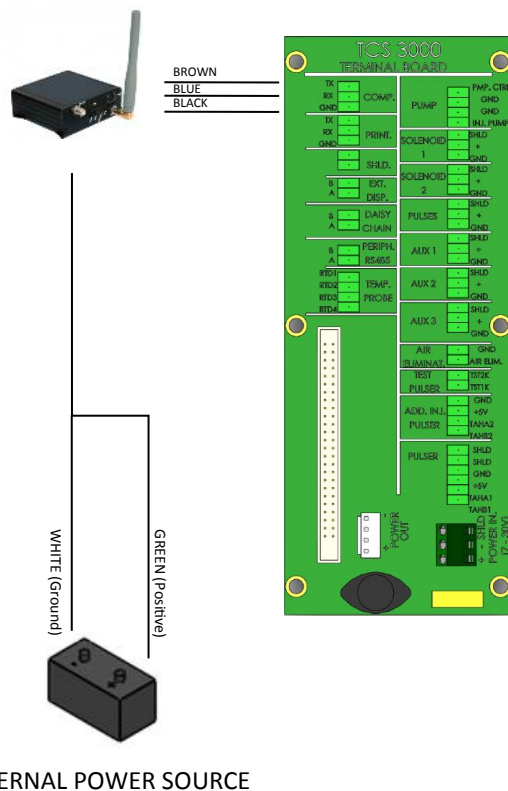
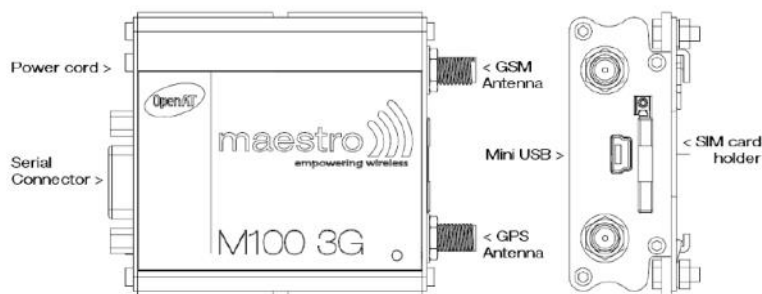

### Status Indicator

The LED will indicate different status of the modem:

- OFF: modem is switched off
- ON: modem has no network and GPS doesn't have a fix
- ON, and OF pulse every 10 seconds: modem has no network and GPS has a fix
- Flashing slowly: modem is registered on the network and GPS doesn't have a fix
- Flashing rapidly: modem is registered on the network and GPS has a fix

### 4-Pin Power Connector

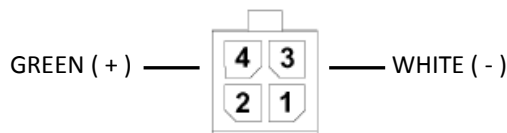



## Installation Procedure — Remote Display

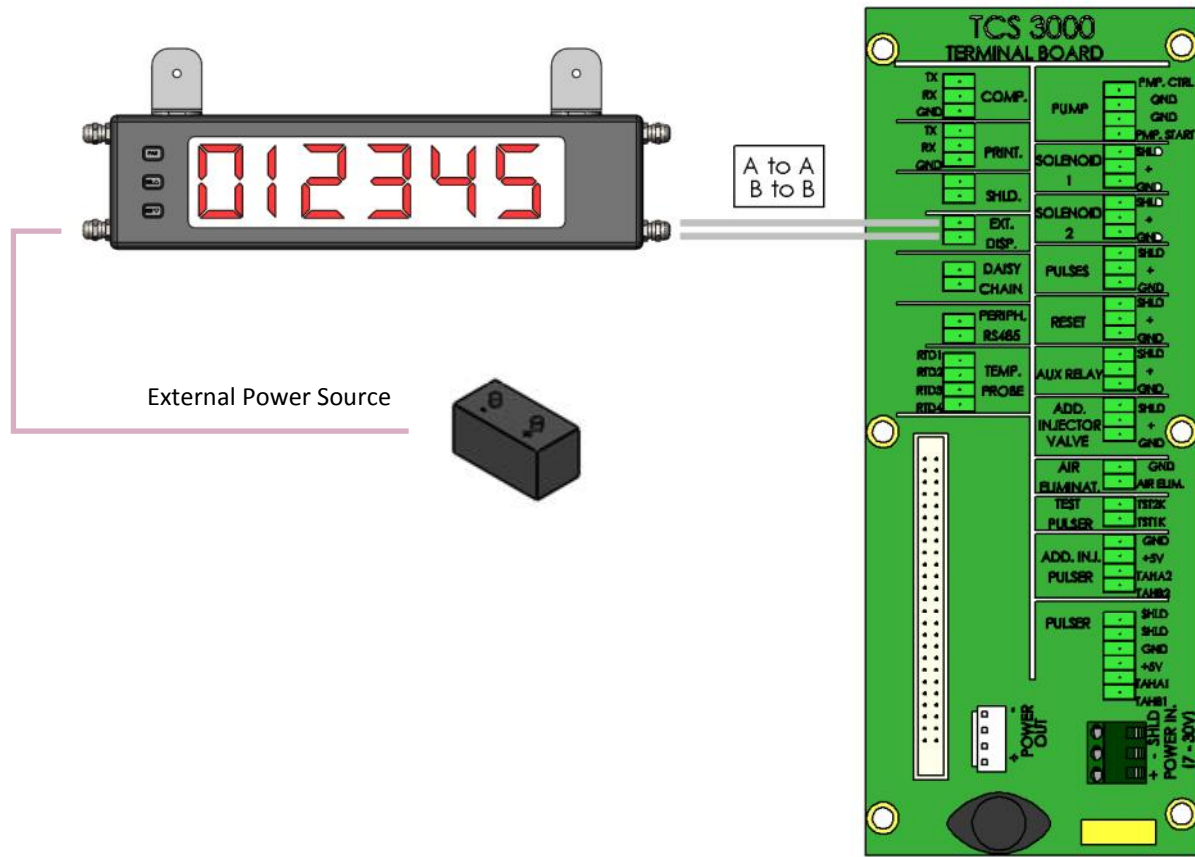

### Installation Procedure:

See Red Lion, Omega or Tekinno serial slave display manuals for RS-485 programming and wiring Instructions.

**WARNING:** The external remote display requires an External Power Source, do not pull power from the TCS 3000 register.

## Installation Procedure — 1 Channel Communication Installation

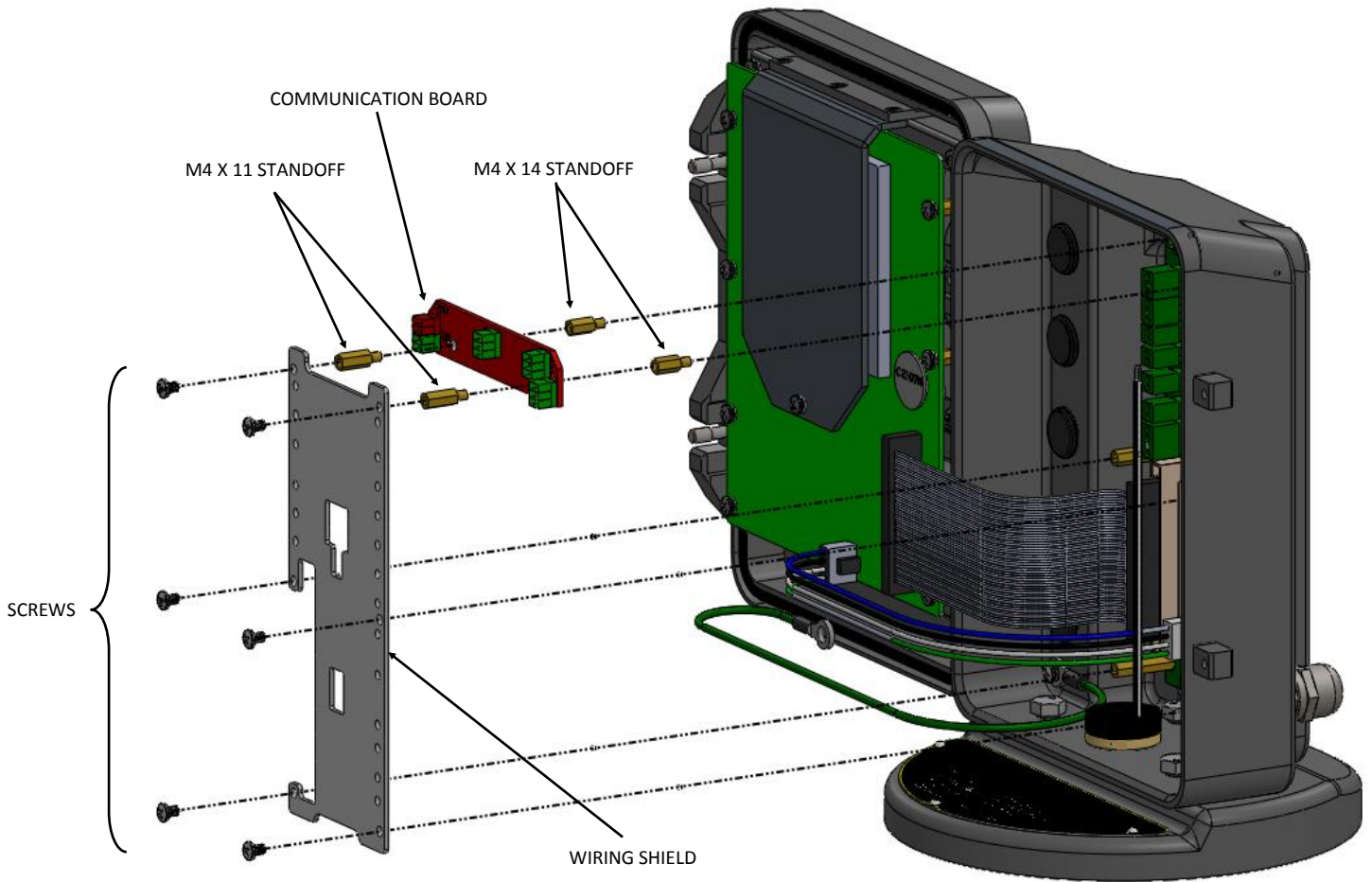

### Installation Procedure:

1. Remove the six Screws holding the Wiring Shield to the M8 x 27 Standoffs.
2. Remove the two top M8 x 27 MM Standoffs and replace with two M4 x 14 Standoffs
3. With two M4 x 14 Standoffs, mount the Single Channel Communication Board over the two top (short) M4 x 11 Standoffs.
4. Install the Wiring Shield with six Screws.
5. Replace USB cable adapter into wiring shield for safe keeping.

## Installation Procedure — Differential Pressure

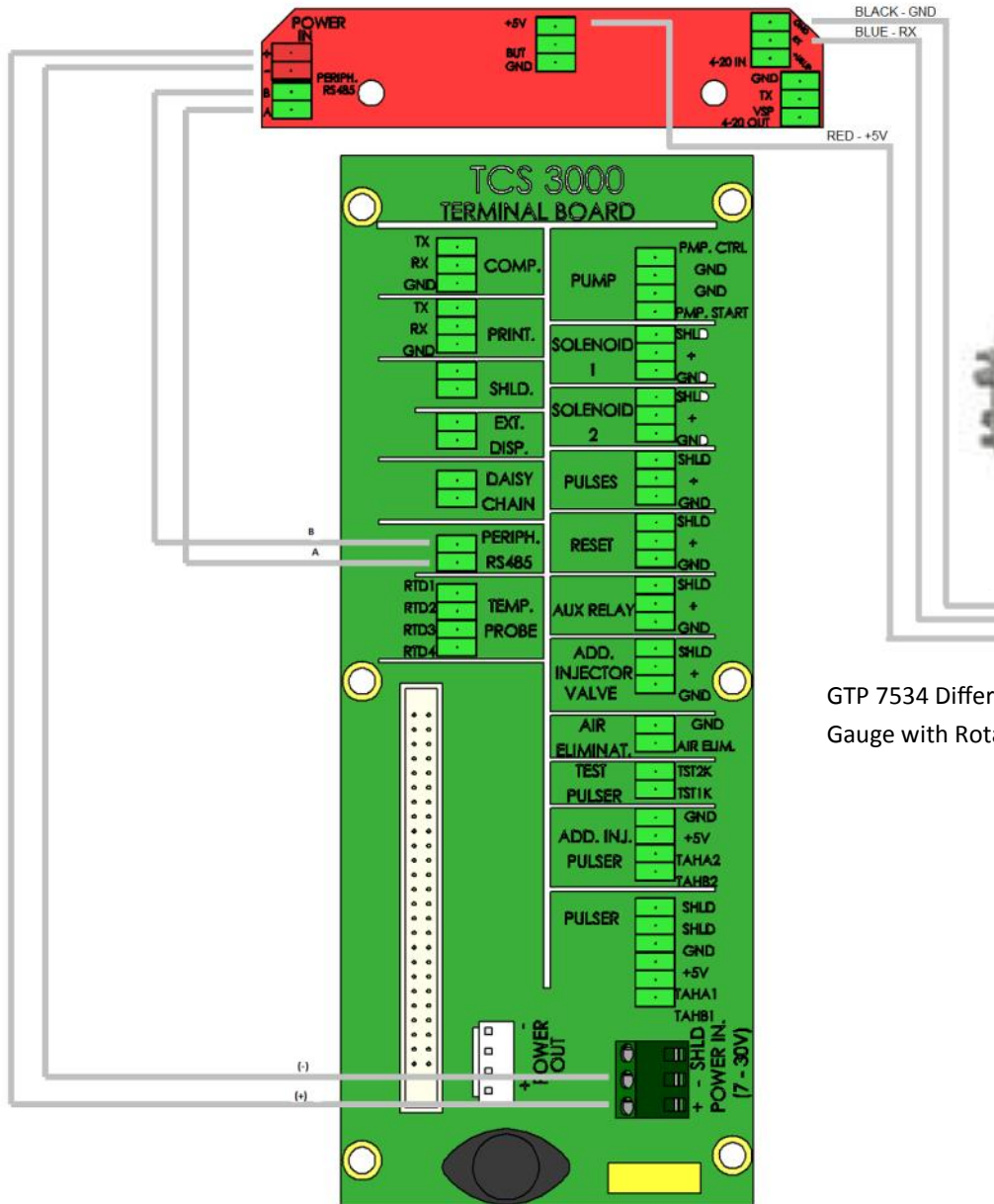

GTP 7534 Differential Pressure Piston Gauge with Rotary Encoder



## Installation Procedure — 8 Channel Communication

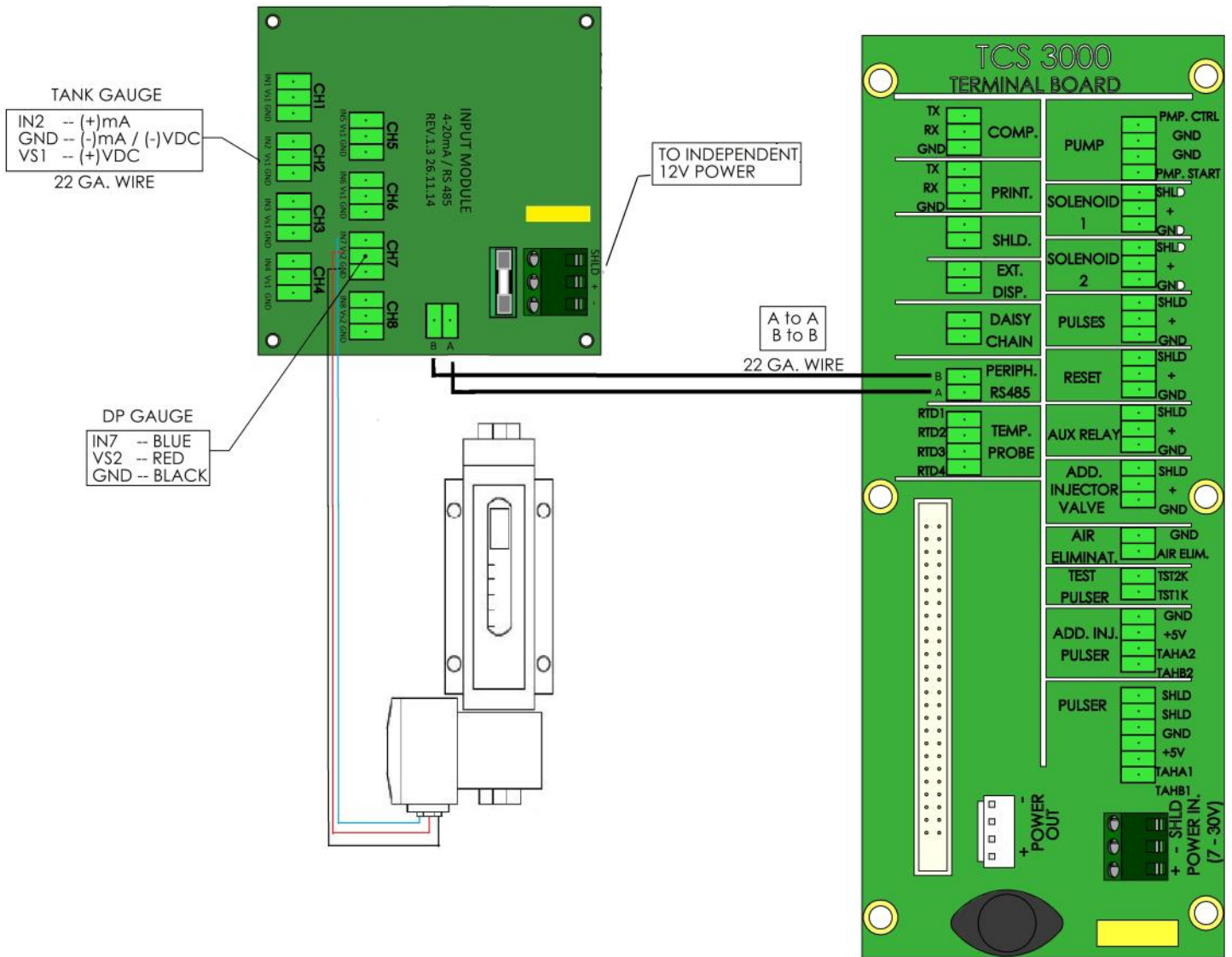

## Installation Procedure—Wiring Diagrams

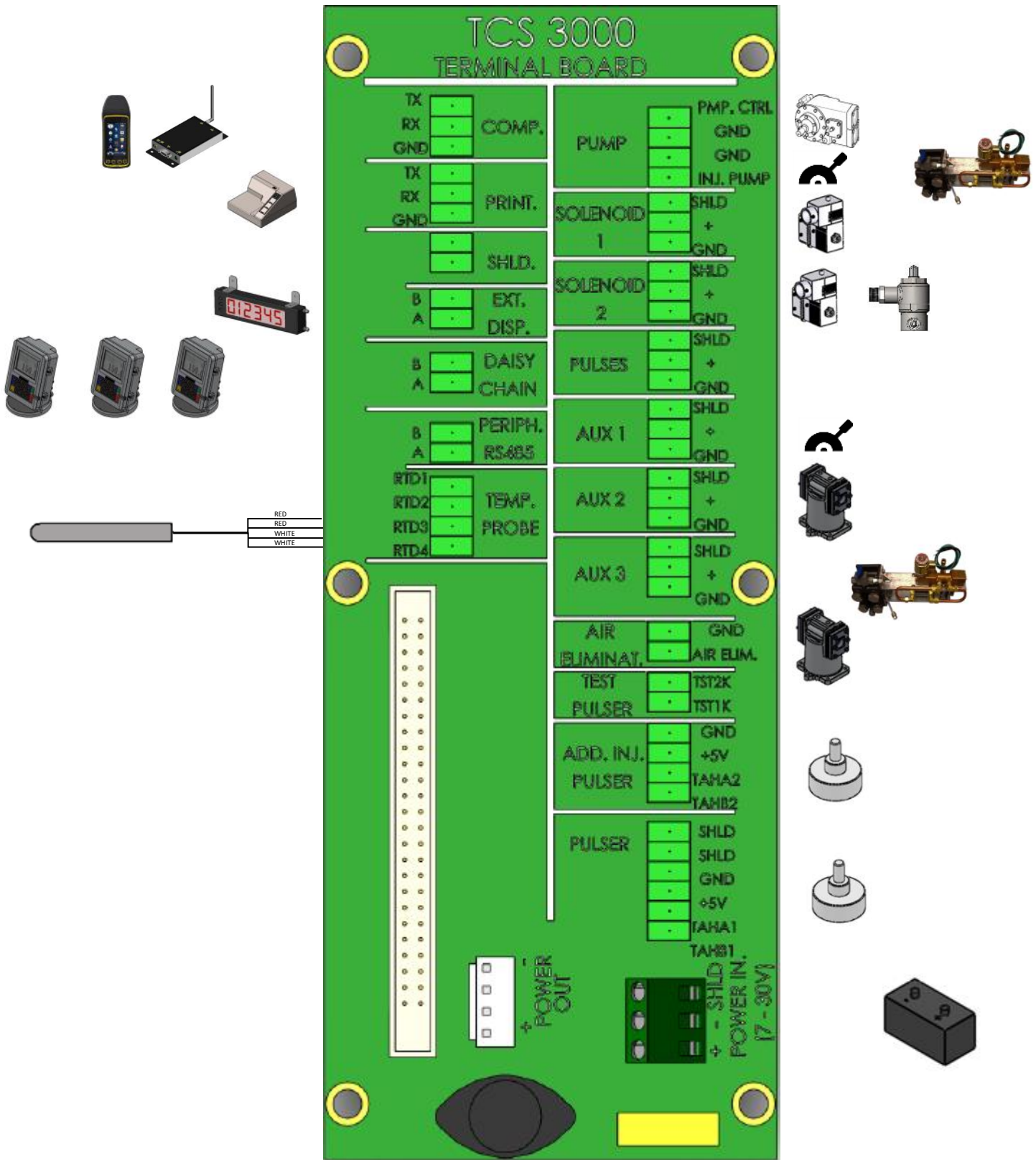

## Installation Procedure — Software Update

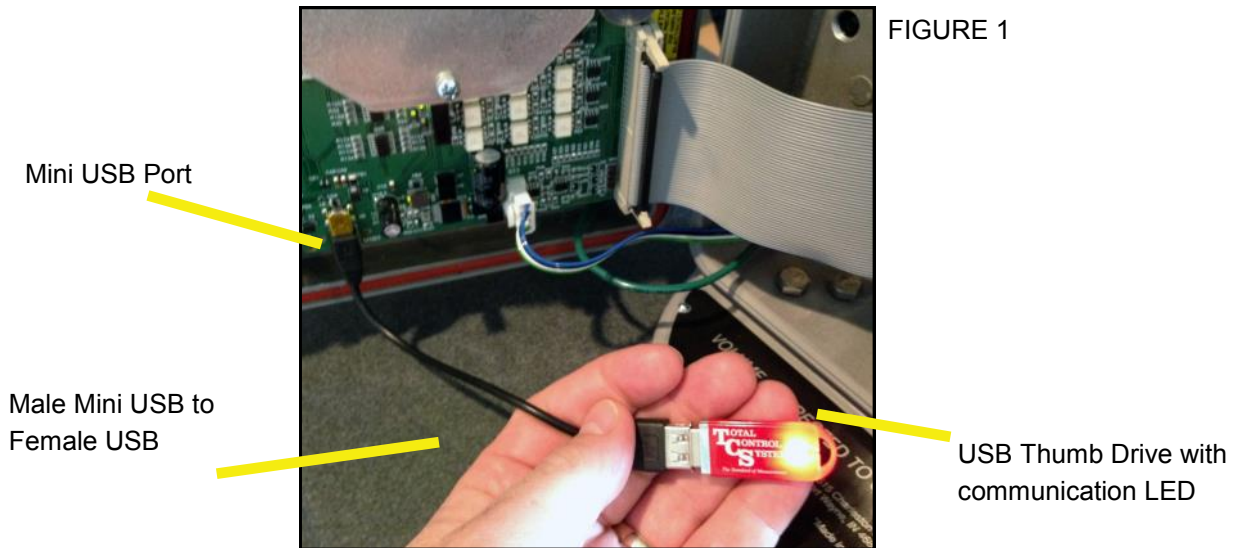

FIGURE 1

Item	Qty	TCS P/N
USB FEM/Mini Male Cable	1	TCS 300787
TCS 3000 USB	1	TCS 300795

TCS 3000 Software Update Kit (TCS 300882)

### Installation Procedure:

1. Load new software upgrade to a USB thumb drive (Minimum 8G, Formatted FAT 32).

NOTE: The new software upgrade should be the ONLY file on the drive.

2. Open the TCS 3000 register. On the front cover of the register, there are 2 mini-USB connections. Using a factory supplied USB cable, attach the thumb drive to the USB port closest to the inside of the register. This port is the highest on the circuit board of the two. See Figure 1.
3. Plug the USB cable into the USB port, and then insert the USB thumb drive into the mating cable (see Figure 1).
4. Under Advanced Functions, locate System Update and press ENTER.
5. The screen will display System Update, press MODE to continue with the update.
6. If the thumb drive is not recognized or there is a faulty cable, the display will respond with NO UPDATE DATA error message.
7. Once the file is recognized, you will be prompted to remove the media. Remove the USB and the register will re-boot and begin the update process. This should take approximately 3 minutes.

## Installation Procedure — Replacement Register Front Cover

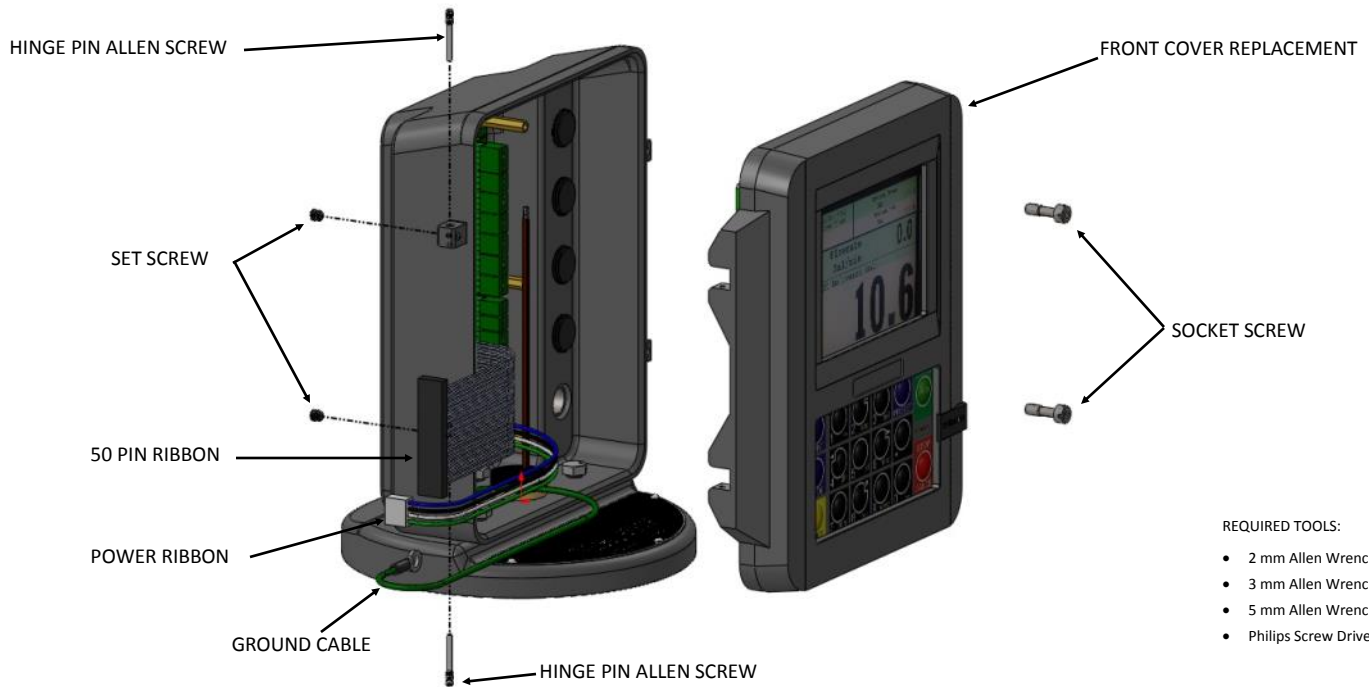

### Installation Procedure:

1. Unlatch the 50 Pin Communication and the Power ribbon cables from the front cover assembly.
2. Remove the grounding strap from the front cover assembly using a Philips screw driver.
3. Remove two Set Screws from the rear housing of the register hinges using a 3 mm Allen Wrench.
4. Remove the two Hinge Pin Allen Screws from the top and bottom of the front cover assembly. Use a 2 mm Allen Wrench for removal.
5. Once the replacement front cover computer is received, carefully remove the unit from the anti-static plastic bag and do not dispose of the original packaging materials.
6. Reassemble the replacement front cover computer assembly to the rear housing with the Hinge Pin Allen Screws and Set Screws.
7. Insert the 50 Pin Communication and Power ribbon cables and fastening the grounding cable.
8. Insert the front cover assembly in the anti-static bag and carefully place back into the original box packaging.

NOTE: Packing instructions are within the original box.

9. Before shipping back to Total Control Systems, be sure to have a Returns Goods Authorization enclosed within the packaging.



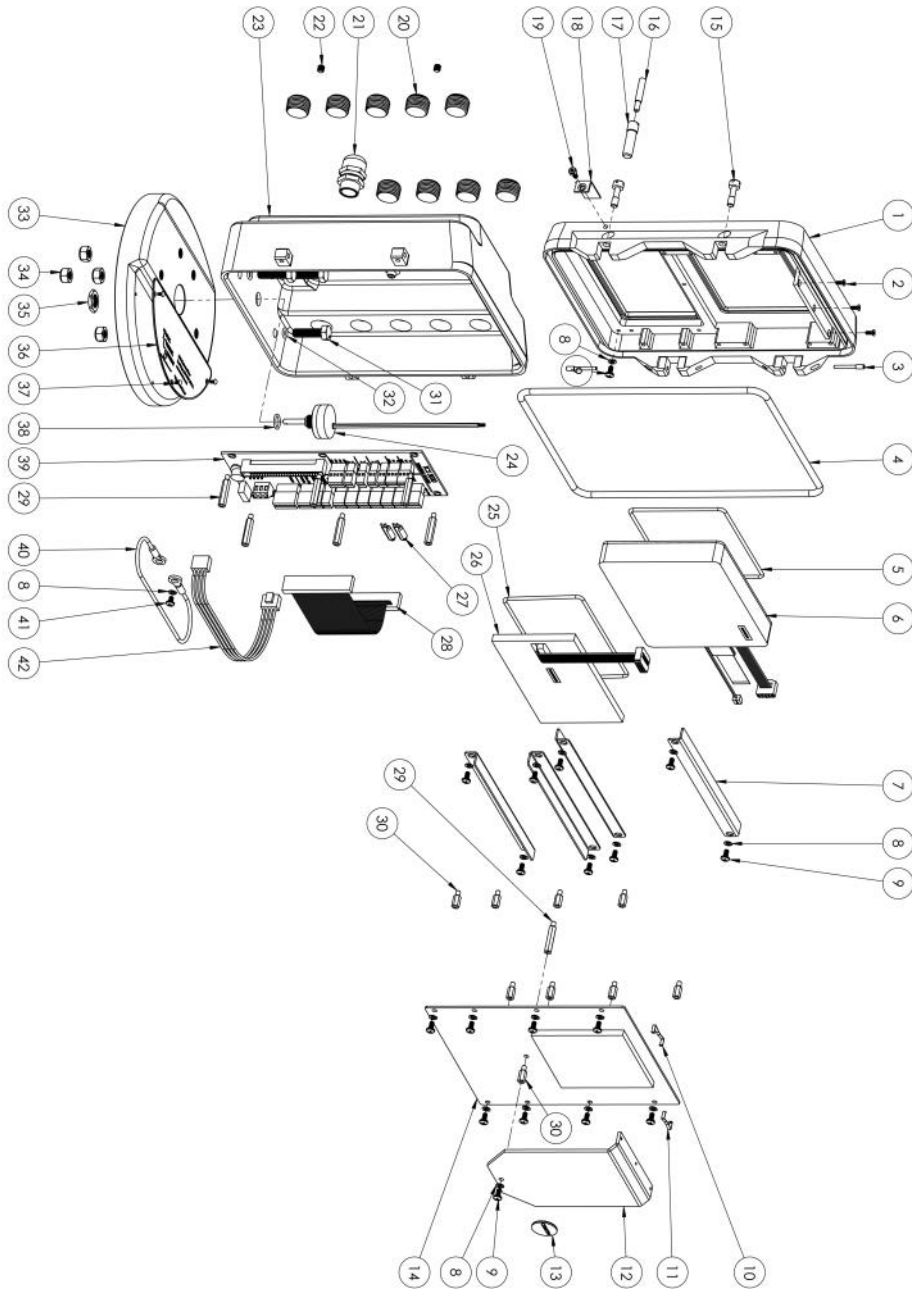

ITEM NO.	PART NUMBER	DESCRIPTION	QTY.	ITEM NO.	PART NUMBER	DESCRIPTION	QTY.	ITEM NO.	PART NUMBER	DESCRIPTION	QTY.
1	300150	FRONT COVER	1	15	300171	SOCKET SCREW M6-1.0X20 DRILLED	2	30	300125	M4X11 STANDOFF	9
2	300122	SRT CNTRSNK HD SCRW M3X8	3	16	300156	CALIBRATION STUD	1	31	300202	HX HD SCREW M8-1.25X30 SS	4
3	300172	HINGE PIN	2	17	300158	CALIBRATION STUD BODY	1	32	300206	O-RING 6MM X 2MM	4
4	300174	GASKET COVER	1	18	300153	CALIBRATION LABEL	1	33	300210	TCS 3000 STAND W/HELICOILS	1
5	300144	GASKET DISPLAY	1	19	300154	M4 X 8 SHCS DRILLED	1	34	300204	NYLON LOCKNUT, M8, 1.25, SS	4
6	300320	DISPLAY WITH SCREEN PROTECTOR	1	20	300252	PLUG, 1/2" NPT UL	9	35	300162	PULSER NUT, 1/2-32 HEX	1
7	300131	COMPRESSION BAR WITHOUT TABS	4	21	300133	CORD GRP 1/2" NPT UL	1	36	300217	NAMEPLATE	1
8	300138	SPRING WASHER, M4, ZC-STEEL	20	23	300290	90 DEG. REAR HOUSING 1/2" NPT	1	37	790095	#4 X 3/16 DRIVE SCREW	3
9	300137	PHILLIPS PAN M4X8 ZC-STEEL	18	24	300160	PULSER	1	38	300166	O-RING, FRM	1
10	300261	REMAINING CLIP X2 CONNECTOR	1	25	300144	GASKET KEYBOARD	1	39	300112	TERMINAL BOARD W/ CONNECTOR	1
11	300260	REMAINING CLIP X1 CONNECTOR	1	26	300230	KEYBOARD ASSEMBLY, TCS3000	1	40	300181	6" GRND WIRE W/RING TERM	1
12	300120	RADIATOR	1	27	300759	RESISTOR WITH SHRINK TUBE ASSEMBLY	2	41	300151	PHILLIPS PAN M4X6 ZC-STEEL	2
13	300797	REPLACABLE BATTERY	1	28	300174	50 PIN X 6" RIBBON CABLE	1	42	300177	4 PIN X 6" POWER RIBBON CABLE	1
14	300110	PC BOARD ASSEMBLY	1	29	300124	M4 X 27 STANDOFF	7				

## **WARRANTY**

New 3000 electronic registers, equipment or components manufactured by Total Control Systems, a division of Murray Equipment, Inc. (TCS) with which this warranty is enclosed, are warranted by TCS to the original purchaser only for a period of TWELVE (12) months from installation or eighteen (18) months from the date of shipment, to be free, under normal use and service, from defects in material and workmanship.

Defects occurring within the stated warranty period, TCS will repair or replace, at TCS's option; provided that part or parts are returned to TCS transportation charges prepaid, and TCS's examination discloses the parts or workmanship to have been defective upon delivery to the purchaser.

## **EXCLUSIONS**

Warranty does not cover any parts and equipment not manufactured by TCS, but these items may be covered by separate warranties of their respective manufacturers. This warranty does not extend to any equipment that has been subjected to misuse, negligence or accident or if operated in any manner other than in accordance with TCS's operating instructions and specifications.

## **CLAIM PROCEDURES**

In order to obtain performance by TCS of its obligations under this warranty, the original purchaser must obtain a Return Goods Authorization (RGA) number from TCS's customer service department within 30 days of discovery of a purported breach of warranty, but not later than the expiration of the warranty period. Once authorization is received, return the defective meter, piece of equipment, or component covered by this warranty, with transportation charges prepaid, to TCS at the address shown below together with a written statement setting forth the nature of the defect and RGA number.

## **LIMITATIONS**

THERE ARE NO OTHER WARRANTIES OF ANY KIND, EXPRESS OR IMPLIED. TCS SPECIFICALLY DISCLAIMS ANY WARRANTY OF MERCHANTABILITY OR OF FITNESS FOR ANY PARTICULAR PURPOSE. TCS will determine if all parts or meter defect falls within the warranty guidelines and will repair or replace within a reasonable time span. TCS is not responsible for any in or out bound freight. TCS's sole obligation that shall represent the buyer's sole and exclusive remedy shall be to repair or at TCS's option to replace any product or part determined to be defective. In no event shall TCS be liable for any special, direct, indirect, incident, consequential or other damages of similar nature, including without limitation, loss of profits, products, production time, or loss of expenses of any nature incurred by the buyer or any third party. TCS has not authorized on its behalf any representation or warranties to be made, nor any liability to be assumed except as expressly provided herein; there is no other express or implied warranty.

## **DESIGN AND EQUIPMENT CHANGES**

Any changes in design or improvements added shall not create any obligation to install same on equipment previously sold or ordered.





**The Standard of Measurement**

2515 Charleston Place  
Fort Wayne, IN 46808

Toll Free: (800) 348-4753  
Phone: (260) 484-0382  
Fax: (260) 484-9230  
Email: [sales@tcsimeters.com](mailto:sales@tcsimeters.com)  
Website: [www.tcsimeters.com](http://www.tcsimeters.com)