



SM700 Series Cold Water Meters Instructions for Storage, Handling and Installation

Maintenance requirements

The SM700 series of cold water meters typically do not require routine maintenance. The water meter is powered by a 3.6 volt battery. Low battery power is indicated by the display digits flashing on and off, at which stage the meter should be replaced. This should be undertaken within three months. The SM700 series of cold water meter features a removable battery pack to allow for disposal separately to the rest of the meter. For battery pack removal instructions, please refer to the separate instructions numbered **D-1001-1**.

Note: The batteries used in this meter are potentially hazardous if damaged. Battery disposal should be undertaken with consideration to any requirements by law for the disposal of Lithium-thionyl chloride batteries.

Health & Safety information

In installations where the pipework is part of an electrical earthing circuit the inlet and outlet pipes must be connected by a permanently bonded electrical earth grounding strap.

Note: The battery carries a warning as follows:- Fire, explosion and severe burn hazard. Do not crush, recharge, disassemble, heat above 212°F (100°C) or incinerate. **Do not** short-circuit.

Contact Information:

United States
Elster AMCO Water, LLC
10 SW 49th Avenue, Building 100
Ocala, FL 34474
T +1 800 874 0890
F +1 352 368 1950
watermeters@us.elster.com
www.elsteramcowater.com

Note: Only products bearing the NSF Mark are certified.



Certified to
NSF/ANSI 61



Due to our policy of continual improvement we reserve the right to change the specification without prior notice.

This document covers the SM700 series

Introduction

The SM700 series of cold water meters are designed to conform to AWWA C700/ C713 specification. The meters are rated at 150psi (10 bar). The meter designation is indicated on the display facia and the case. Air or air/water mixtures will typically have no damaging effect on the internal components of the meter and air flow through the meter will not be registered.

Installation instructions

- Remove the two plastic thread protection caps before installation.
- The meter must be installed with the arrow pointing in the direction of the water flow.
- Cut the pipework to the correct size (see Table 1 for lay length). This is important to prevent tensile loading across the meter when tightening.
- Ensure that the pipework is aligned correctly prior to installation of the meter. Do not use the meter as a lever to align the pipework in any manner.
- Ensure that the pipes are flushed and sealing faces are free from debris and contamination.
- Fit the meter to the service pipework in accordance with standard installation practice.
- Ensure that rubber or fibre sealing washers are fitted between the pipe and water meter connections. Where washers are supplied with the meter, these must be used. **Do not** use P.T.F.E tape or sealing paste to provide a water tight seal.
- Locate the nuts on the pipework onto the meter threads and screw on finger tight. Care should be taken to prevent cross threading or stripping of threads when making the connection.
- Tighten the nut a further quarter to half a turn using a wrench. Typical torque 11 ft-lbs min. to 14.75 ft-lbs max. (15Nm min. to 20Nm max.). **Do not over tighten.**
- If the meter is connected **do not** solder or make any solder joints within 8 inches of the meter. If soldering is undertaken, aim torch away from meter at all times.
- Ensure the pipework is securely fixed to avoid vibration or bending across the meter.
- The meter should be installed away from sources of heat and out of direct sunlight.
- The meter installation should be protected from freezing.
- The meter can be fitted to horizontal, vertical or inclined pipework.
- When water has been turned on check all joints for signs of leakage.
- It is recommended to thoroughly purge the entire water system, including all valves and pumps, of air prior to recording any reading as required by the utility.
- For connection to a remote reading system, see the manufacturer's instructions and refer to table 2 of these instructions for wire color assignments when required.

Handling and Storage

The meter should be handled with care and must not be dropped or subjected to impact. It is recommended the meter be stored under controlled conditions, preferably at a temperature between 15°F (-10°C) & 105°F (+40°C) and kept away from direct sunlight. The meter should remain boxed, with the two plastic thread protection caps in place, until the point of installation. Do not carry the water meter by the attached cable.

Fitting should be undertaken by a competent trained installer. These instructions should be read and understood before commencing the installation.

Note: Do not install the communications cable along or within 6 inches of existing cable runs.

Reading the meter

The reading is displayed on the totalizer module of the meter under a protective lid. The display digits before the decimal point, surrounded by a black or both a black and white border on the facia, represent whole US gallons (gal.), cubic feet (ft³) or cubic meters (m³) and the digits after the decimal point, surrounded by a red border, represent fractions of a gallon, ft³ or m³. When water is flowing a flashing square icon appears to the lower right of the display, but when the flow has stopped this indicator will be extinguished. To read the meter using a remote reading system, refer to the manufacturer's instructions.

Table 1

AWWA Meter Size	Meter Length	Straight Pipe Connection Thread
5/8" x 1/2"	7 1/2"	3/4"
5/8" x 3/4"	7 1/2"	1"
3/4" x 3/4"	7 1/2"	1"
3/4" x 3/4"	9"	1"
3/4" x 1"	9"	1 1/4"
1"	10 3/4"	1 1/4"

Figure 1

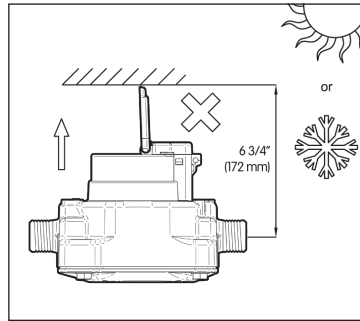

The top of the meter should be clear of any obstruction to allow for lifting the lid for reading the meter. The meter should be installed away from sources of heat & direct sunlight and protected from freezing.

Figure 2

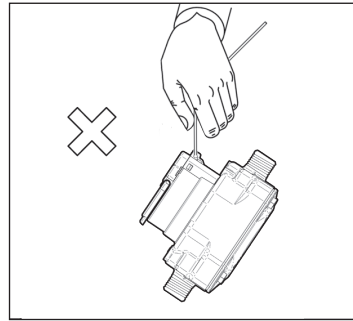

Do not carry the water meter by the attached cable.

Figure 3

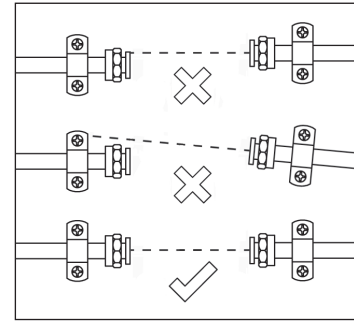

Ensure that the pipework is aligned correctly prior to installation of the meter. **Do not** use the meter as a lever to align the pipework in any manner.

Figure 4

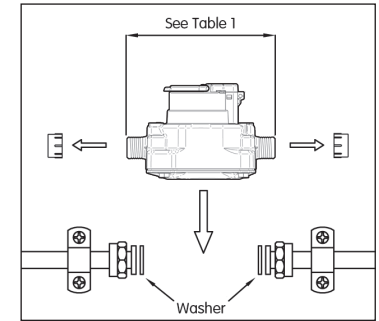

Remove the two thread protection caps. Install with the arrow pointing in the direction of the water flow. **Cut the pipework to the correct size. This is important to prevent tensile loading across the meter when tightening the flange nuts.**

Figure 5

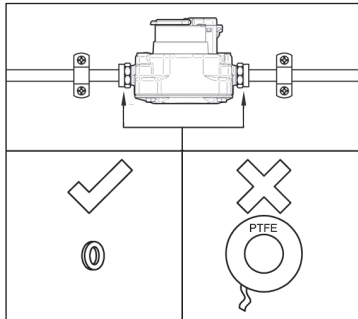

Ensure that the pipes are flushed and sealing faces are free from debris and contamination. Fit meter between the pipe connections using rubber or fiber sealing washers. Where washers are supplied with the meter, these must be used. **Do not** use PTFE tape or sealing paste.

Figure 6

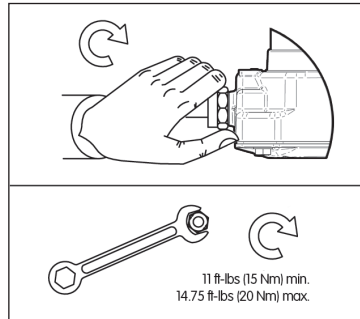

Locate the nuts on pipework onto the meter threaded flanges. Screw on finger tight. Note: care should be taken to prevent cross threading. **Tighten the nuts a further 1/4 to 1/2 turn using a wrench, typical torque of 11 ft-lbs min. to 14.75 ft-lbs max. (15 Nm min. to 20 Nm max.).**

Figure 7

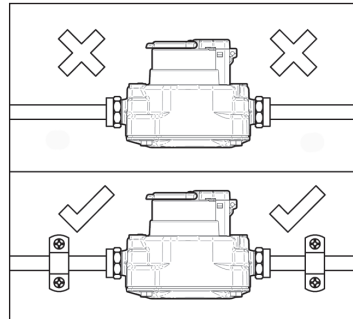

Securely fix the pipework to avoid vibration or bending across the meter. **When fitting the pipe supports it is important that both sides of the pipework are aligned to prevent bending forces being applied across the meter.**

Figure 8

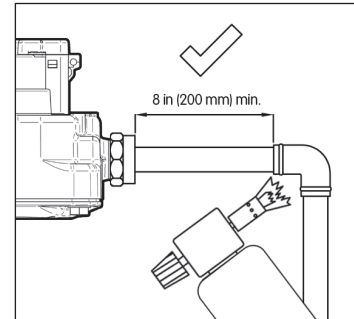

If the meter is connected do not solder or make any solder joints within 8 in (200 mm) of the meter connections. If soldering is undertaken, aim torch away from meter at all times. **Do not allow corrosive chemicals on or near the meter (i.e. solder flux, aggressive cleaning products etc.).**

Figure 9

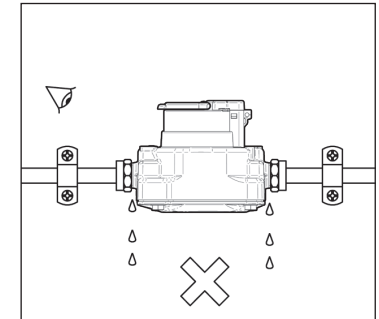

When water has been turned on check all joints for signs of leakage or slight seeping at the nut to meter interface. **Connections must be watertight.** Purge the meter to remove all air from the pipe and meter.

Figure 10

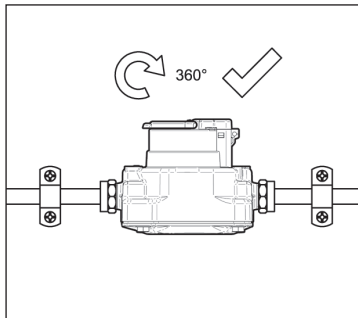

The meter can be fitted to horizontal, vertical or inclined pipework.

Figure 11

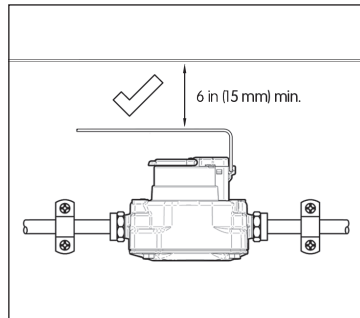

Note: **Do not** install the communications cable along or within 6 in (150 mm) of existing cable runs.

Figure 12

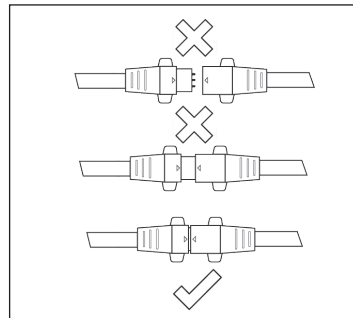

Where an in-line connector is used make sure that the two mating components are pushed together fully and locked (where applicable) to ensure correct connection and seal from moisture.

Table 2

Communications type	Termination		
Function	Clock or Data Request	Data	Ground
Meter interface cable	Red wire	Green wire	Black wire
WallPad	*Screw terminal 1	*Screw terminal 2	Not connected
PitPad	Red wire	Green wire	Not connected

* Connection polarity unimportant

Any interconnection cables should be joined with a suitable connection to prevent moisture ingress. Any unused cores of the wire should also be sealed.