



Blancett[®]
Turbine Flow Meters

Turbine Flow Meter

Model 1200

DESCRIPTION

The Blancett Model 1200 in-line turbine flow meter was engineered for applications in highly corrosive environments. Developed for use in petrochemical and other process industries with liquid chemical flows, the Model 1200 turbine meter provides accuracy and durability in aggressive industrial environments. The meter features a 303 stainless steel body and internal wetted parts, with two type-440 stainless steel ball bearings.

The Model 1200 maintains measurement accuracy and mechanical integrity in the corrosive and abrasive fluids commonly found in oil field water flood projects and many industrial applications.

When paired with a Blancett flow monitor, the Model 1200 turbine meter meets a wide range of measurement requirements. This makes it ideal for applications such as pipelines, production/injection fields, mining operations, offshore facilities, and other industrial applications. For a full list of Blancett flow monitors, see www.badgermeter.com.

FEATURES

- Offers accurate and repeatable flow measurement in ranges from 0.25...25 gpm (0.57...94.64 lpm)
- Cost-effective solution for turbine flow meter applications
- 303 stainless steel construction offers long service life in severe operating environments
- Available in NPT end connections
- NIST traceable calibration
- Installation in pipe sizes 1/4...3/4 inch (6.35...19 mm), with or without a bypass line
- Integrates electronically with a Blancett B2800 flow monitor
- K-factor Scaler, or the F to I/F to V Intelligent Converter Field replaceable repair kits allow for turbine replacement without loss of accuracy



INSTALLATION

The Model 1200 turbine meter is simple to install and service. It operates in a horizontal orientation with the flow direction arrow aligned in the same direction as the actual line flow. For optimum performance, install the flow meter with a minimum of 10 diameters upstream straight pipe length and 5 diameters downstream straight pipe length.



Badger Meter

TRB-DS-02785-EN-04 (October 2018)

Product Data Sheet

OPERATING PRINCIPLE

Fluid entering the meter passes through the inlet flow conditioner, which reduces its turbulent flow pattern and improves the fluid's velocity profile. The fluid then passes through the turbine, causing the turbine to rotate at a speed proportional to the fluid velocity. As each turbine blade passes through the magnetic field, the blade generates an AC voltage pulse in the pickup coil at the base of the magnetic pickup (see *Figure 1*). These pulses produce an output frequency proportional to the volumetric flow through the meter. The output frequency represents flow rate and/or totalization of fluid passing through the turbine flow meter.

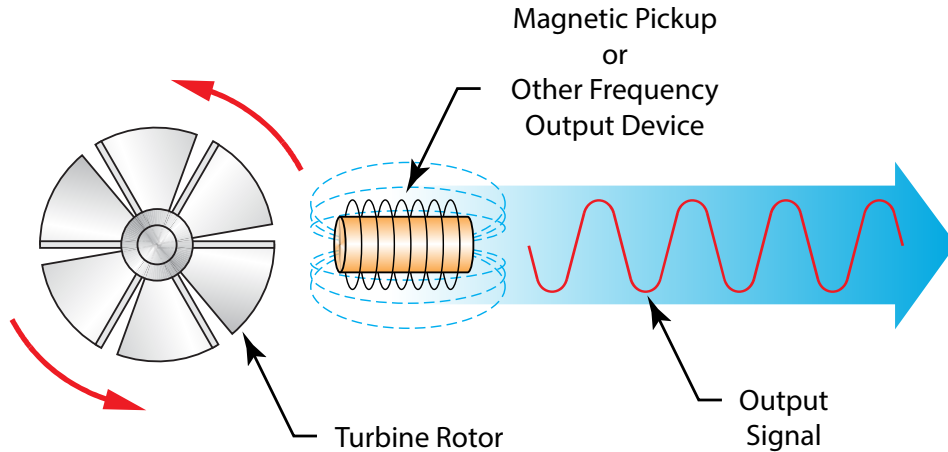

Figure 1: Schematic illustration of electric signal generated by rotor movement

K-Factor

The K-factor represents the number of output pulses transmitted per gallon of fluid passing through the turbine meter. Each turbine has a unique K-factor. However, turbine meters are not functionally consistent throughout the full flow range of the meter.

There are several forms of friction inherent in the turbine meters that retard the rotational movement of the turbine rotor. These frictional forces include: magnetic drag, created by electromagnetic forces of pickup transducers; mechanical drag, due to bearing friction; and viscous drag, produced by flowing fluid.

As flow increases, the frictional forces are minimized and the free-wheeling motion of the turbine rotor becomes more linear (proportional to flow). The K-factor becomes relatively constant and the linear throughout the balance of the linear flow range. This is approximately a 10:1 turndown ratio from the maximum flow rate down to the minimum flow rate.

Typical K-factor Curve (Pulse per US Gallon)

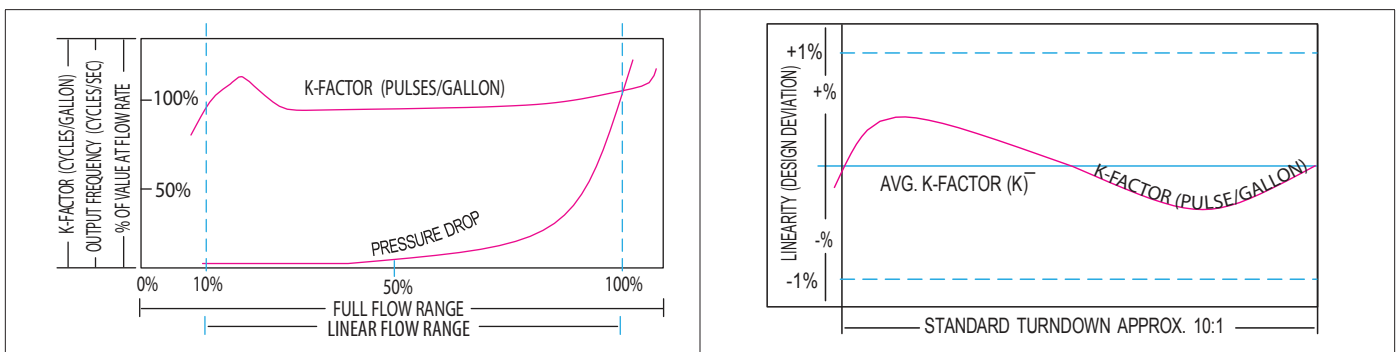

Figure 2: Typical K-factor

SPECIFICATIONS

Materials of Construction	Body	303 stainless steel
	Rotor	CD4MCU stainless steel
	Bearings	Two (2) type-440 stainless steel ball bearings
	Rotor Shaft	303 stainless steel
	Rotor Support	303 stainless steel
	Housing	Epoxy encapsulated module
Operating Temperature	Meter	-60...350° F (-51...1777° C)
	Module	-20...160° F (-7...71° C)
	Pickup	-150...325° F (-101...162° C)
Pressure Rating	4000 psi (276 bar) maximum	
End Connection	NPT male, NPT female	
Turndown Ratio	—	
Accuracy	±1.0% of reading	
Repeatability	±0.1%	
Calibration	MIL-PRF-7024E, Type II (NIST traceable calibration)	
Pickup	—	
Certification	—	
RF Preamplifier	Input Signal	1 millihenry carrier pickup
	Output Signal	10V peak to peak square wave
Power	7...30V DC	
Distance Specification	50 ft maximum between pickup and RF preamplifier 1000 ft maximum between preamplifier and receiving unit	
Electrical Connection	Terminal strip	

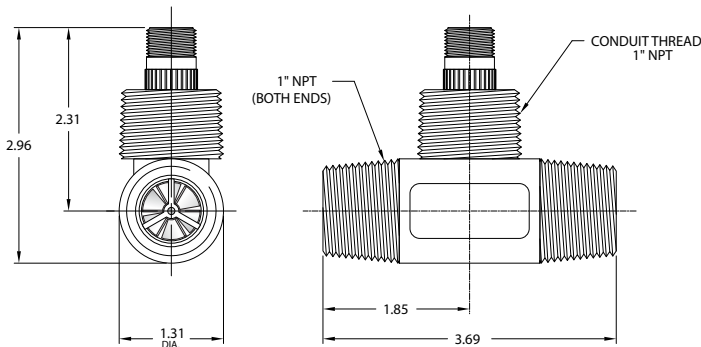

Figure 3: Dimensions

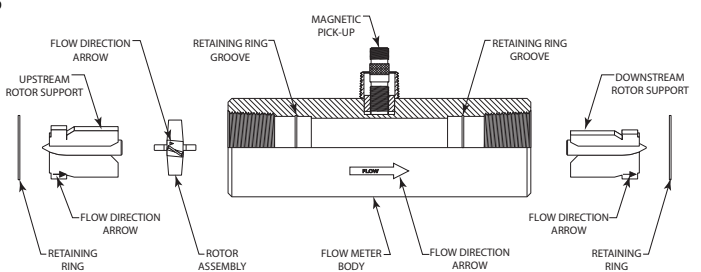

Figure 4: Exploded View

PART NUMBER INFORMATION

Meter with pickups

Part Number	Bore Size	End Connections	Max PSI	Flow Ranges	Strainer Mesh	Approx. K-factor Pulses/Gal	Weight	End to End Length
				gpm (lpm)				
B121-225	1/4 in.	1/2 in. Male NPT	4000	0.25...2.5 (0.95...9.46)	60	29,000...33,000	—	—
B121-250	1/2 in.	1/2 in. Female NPT	4000	0.75...7.5 (2.84...28.39)	60	8500...9500	—	—
B121-275	3/4 in.	1 in. Male NPT	4000	2.5...25 (9.46...94.64)	60	2800...3000	—	—

Meter only (no pickups)

Part Number	Bore Size	End Connections	Max PSI	Flow Ranges	Strainer Mesh	Approx. K-factor Pulses/Gal	Weight	End to End Length
				gpm (lpm)				
B121227	1/4 in.	1/2 in. Male NPT	4000	0.25...2.5 (0.95...9.46)	60	29,000...33,000	—	—
B121251	1/2 in.	1/2 in. Female NPT	4000	0.75...7.5 (2.84...28.39)	60	8500...9500	—	—
B121276	3/4 in.	1 in. Male NPT	4000	2.5...25 (9.46...94.64)	60	2800...3000	—	—

Control. Manage. Optimize.

Blancett is a registered trademark of Badger Meter, Inc. Other trademarks appearing in this document are the property of their respective entities. Due to continuous research, product improvements and enhancements, Badger Meter reserves the right to change product or system specifications without notice, except to the extent an outstanding contractual obligation exists. © 2018 Badger Meter, Inc. All rights reserved.

www.badgermeter.com

The Americas | Badger Meter | 4545 West Brown Deer Rd | PO Box 245036 | Milwaukee, WI 53224-9536 | 800-876-3837 | 414-355-0400
 México | Badger Meter de las Americas, S.A. de C.V. | Pedro Luis Ogazón N°32 | Esq. Angelina N°24 | Colonia Guadalupe Inn | CP 01050 | México, DF | México | +52-55-5662-0882
 Europe, Eastern Europe Branch Office (for Poland, Latvia, Lithuania, Estonia, Ukraine, Belarus) | Badger Meter Europe | ul. Korfantego 6 | 44-193 Knurów | Poland | +48-32-236-8787
 Europe, Middle East and Africa | Badger Meter Europa GmbH | Nurlinger Str 76 | 72639 Neuffen | Germany | +49-7025-9208-0
 Europe, Middle East Branch Office | Badger Meter Europe | PO Box 341442 | Dubai Silicon Oasis, Head Quarter Building, Wing C, Office #C209 | Dubai / UAE | +971-4-371 2503
 Slovakia | Badger Meter Slovakia s.r.o. | Racianska 109/B | 831 02 Bratislava, Slovakia | +421-2-44 63 83 01
 Asia Pacific | Badger Meter | 80 Marine Parade Rd | 21-06 Parkway Parade | Singapore 449269 | +65-63464836
 Switzerland | Badger Meter Swiss AG | Mittelholzerstrasse 8 | 3006 Bern | Switzerland | +41-31-932 01 11