



# MA-4 Positive Displacement Meter (Dispensing)

## LPG Motor Fuel Dispensing

### General Information

The Liquid Controls MA-4 Meter is a specially designed meter for LPG Motor Fuel Dispensers. The meter features an aluminum body with integral bolted on strainer/vapor eliminator and differential valve. No metal-to-metal contact inside the measuring chamber minimizes internal wear and assures sustained accuracy. Refer to the reverse side of this publication for meter dimensions.

The accuracy, linearity and repeatability of the meter exceed all requirements of NIST Handbook 44 and OIML R117. Electronic linearization device (LC SCAMP Pulser) is required to achieve optimal accuracy across full flow range. Definition of terms per ISA S50.1.



### Specifications

#### Materials of Construction

##### Housing

Cast aluminum

##### Internal components

Aluminum, Ni-Resist, and stainless steel

##### Seal materials

Buna N (UL recognized component)

##### Differential Valve

Cast Iron

#### Flow Range

2.5 to 40 GPM (9.5 to 151.5 LPM)

#### Operating Pressure

350 PSI (24.1 Bar)

#### Minimum Burst Pressure

1750 PSI (120.5 Bar)

#### Temperature Range

-40 to +160° F (-40 to +71.1° C)

#### Connections

1" NPT Threaded

#### Linearity

±0.5%

#### Repeatability

0.24%

#### Hazardous Location Rating

Class 1, Division I, Group D (LPG)

#### Enclosure

NEMA 4X

#### Custody Transfer

NTEP (USA)

#### Safety

NFPA 58, UL 25



# MA-4 Positive Displacement Meter (Dispensing)

## Dimensions

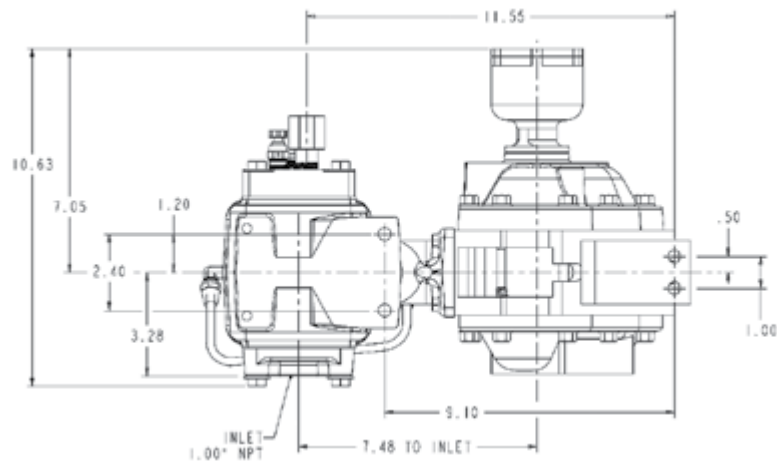
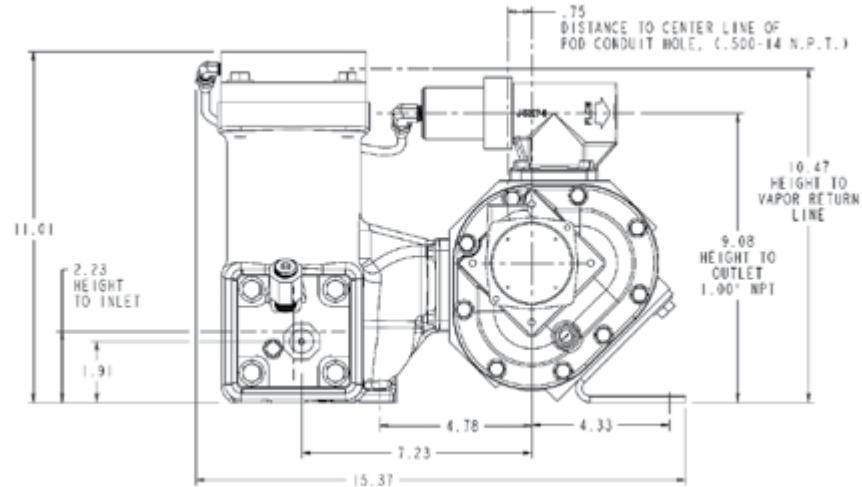

Consult the factory when certified engineering drawings are required.  
 Dimensions shown are not suitable for construction or modifications

