



Specifications

M-80™ Meters



Liquid Controls M Series rotary motion positive displacement (PD) meters offer the ultimate in measurement accuracy for custody transfer of petroleum products and aviation fuels.

Superior performance features

Low pressure drop - will operate on gravity flow or pump pressure.

Sustained accuracy - no metal-to-metal contact inside the measuring chamber means minimal wear and deterioration in accuracy over time, fewer recalibrations, and longer service life. Meters conform to NIST and International Weights and Measures accuracy requirements.

Wide viscosity range - LC meters can accurately meter products from less than 30 SSU (less than 1 centipoise) to 1,500,000 SSU (325,000 centipoise).

Maximum adaptability - choice of stock or custom elbows/fittings provides unequaled mounting flexibility to meet widely varying installation requirements.

Accuracy/Performance*

Repeatability

Capable of 0.02% or better at any flow rate over entire range

Linearity

Over 5:1 range

Mech. registration: capable of $\pm 0.125\%$ or better from max. nom. flow rate

Elect. registration: capable of $\pm 0.10\%$ or better from max. nom. flow rate

Over 10:1 range

Mech. registration: capable of $\pm 0.22\%$ or better from max. nom. flow rate

Elect. registration: capable of $\pm 0.10\%$ or better from max. nom. flow rate

Over 40:1 range

Mech. registration: capable of $\pm 0.5\%$ or better from max. nom. flow rate

Elect. registration: capable of $\pm 0.15\%$ or better from max. nom. flow rate

Temperature range

-40° F to 160° F (-40° C to 71° C)

*Stated accuracy obtainable when all variables remain constant. Reading/measurements reflect a minimum of one minute of flow at selected rate(s). All accuracy statements based on metering safety solvent (aliphatic hydrocarbon), approximate viscosity 1 CPS. On higher viscosity products, the average deviation in accuracy will be less.

Industries served

LC M and MA series meters are well suited for use in industries requiring precise flow measurement and reliable, extended service life:

- Refined petroleum products
- Aviation fuels
- LPG
- Agricultural chemicals
- Paints and coatings
- Foods and beverages
- Petrochemicals
- Pharmaceuticals
- Cosmetics
- Printing Inks
- Textiles

Construction

Meter housing and rotors

Cast aluminum

Internal components

Aluminum, Ni-Resist, stainless steel

Seal materials

UL recognized component: Buna-N, Viton®¹, Teflon®¹

Bearings

Carbon, Teflon, Ni-Resist

¹Viton and Teflon are registered trademarks of DuPont Corporation.

Front View

Top View

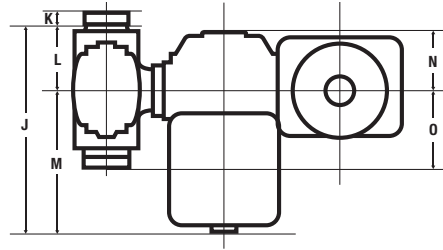
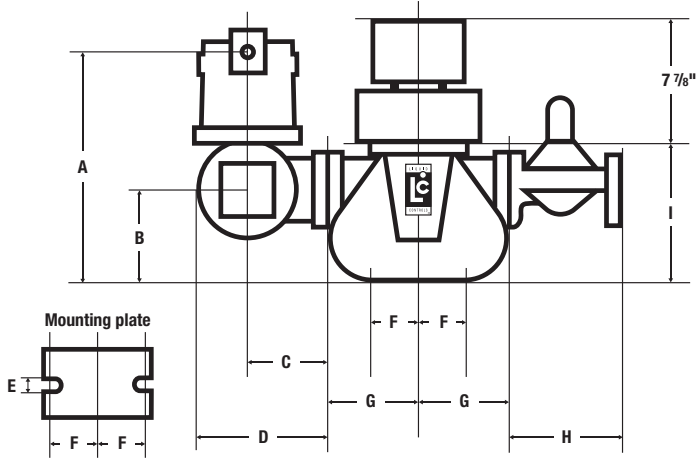

Dimensions: flow meters with electronic registration

Note: Dimensions shown are not for construction use.
Consult factory when certified engineering prints are required.

Model	Flange size	Max. nom. Flow rate	Working pressure	Dimensions														Net Wt			
				A	B	C	D	E	F	G	H	I	J	K	L	M	N		O		
M-80	4" or 6"	800 GPM (3228 L/min)	275 PSI (19 BAR)	in	25	16.6 ^d	5.6	9.1	2"-13t ^d	1.5	14.3 ^d	n/a	20	21	1.4	7	14	8	10	201 lbs (91.2 kg)	
				mm	645	421 ^d	143	230	2"-13t ^d	38	362 ^d	n/a	498	540	36	181	359	213	241		
	6" ²	1000 GPM ² (3785 L/min)	275 PSI (19 BAR)																		

Ordering Information

Model : _____ - _____ - _____ - _____

Description : _____

Flow rates: Max. _____ Normal _____ Min. _____

Operating temperatures: Max. _____ Normal _____ Min. _____

Maximum non-shock operating pressure: _____

Maximum viscosity: _____ @ _____ (Temp°/F or C)

Specific gravity: _____ @ _____ (Temp°/F or C)

Construction class: (1, 2, etc.) _____

Seal material: Standard Buna/Viton All Viton All Teflon

Direction of flow: L to R R to L

Read out: Gallons Liters Pounds Other _____

Mechanical counter and printer: Zero/Face up Zero/Face down Accumulative

Strainer basket : 40M 80M 100M Other _____

Flange size: _____

Flange type: NPT BSPT Slip weld ANSI DIN Other _____

Options: _____

Class Description

2 Aviation and jet fuel

Bearing Material

Ni-Resist¹

¹ Carbon bearings are standard on some meter sizes of this class. Consult factory.

² M-80 Meters are capable of momentary overload operation at 125% of maximum rated capacity in either direction without damage to mechanism (applies to Class 2 meters on jet fuel only). 125% overload operation (1,000 GPM) requires 6" ANSI or 6" Victaulic[®] connections.

Victaulic[®] is a registered trademark of Victaulic Company.

Material of Construction

Class 2 Meters

For metering aviation gasoline and jet fuels when meter is installed downstream of the filter/separator. Non-ferrous construction meters may be operated at rated capacity. Buna-N / Viton seals standard. Teflon seals optional.



LIQUID CONTROLS

A Unit of IDEX Corporation
105 Albrecht Drive
Lake Bluff, IL 60044-2242
1.800.458.5262 • 847.295.1050
Fax: 847.295.1057
www.lcmeter.com

© 2007 Liquid Controls
(04/13)

