

General Information

The SeaMetrics FT410 is a compact digital flow monitor with user-programmed output features. Combined with an IP Series insertion flow sensor or a WT turbine meter, it is ideal for flow rate and total indication, chart recording, and proportional chemical feed. It is available in wall or panel-mount enclosures, or in a round cast-aluminum housing mounted directly on a SeaMetrics meter. For wall-mounting, the non-metallic enclosure is splashproof and has a clear cover. The housing for panel mounting is standard 1/4 DIN-sized, with gasketed front panel and membrane switches. Wall and meter-mounted enclosures are NEMA 4X; Panel-mounted enclosures are NEMA 12.

An eight-digit totalizer is resettable, unless ordered with non-reset option. Programming prompts simplify set up by indicating the next step. Pulse output is a programmable 0.1 second open-collector transistor pulse (an optional dry contact pulse output is available) which is compatible with electronic metering pumps, PLC's, computer input cards, and SeaMetrics controls. An optional 4-20 mA output feature is front-panel programmable in standard flow rate units.

Features

Specifications

Power	11-28 VDC
Flow Sensor Power	5 Volts DC, 50 mA maximum
Temperature	0° C to 70° C
Display	Custom 8-digit LCD, 0.4" digits
Totalizer	8-digit resettable (non-reset optional)
Rate Indication	8-digit
K Factor Range	.050 - 2000.000
Pulse Output Range	0.1 - 200000.0 gallons per pulse
Pulse Output	0.1-second open-collector transistor, 100 mA, 40 VDC maximum; optional FORM C SPST relay contact closure 5A @ 24VDC
Analog Output (Optional)	4-20 mA isolated 24 VDC, 500 Ohm maximum; may be wired non-isolated
Analog Output Resolution	500 counts full scale
Sensor Output	100 mA, 40 VDC maximum

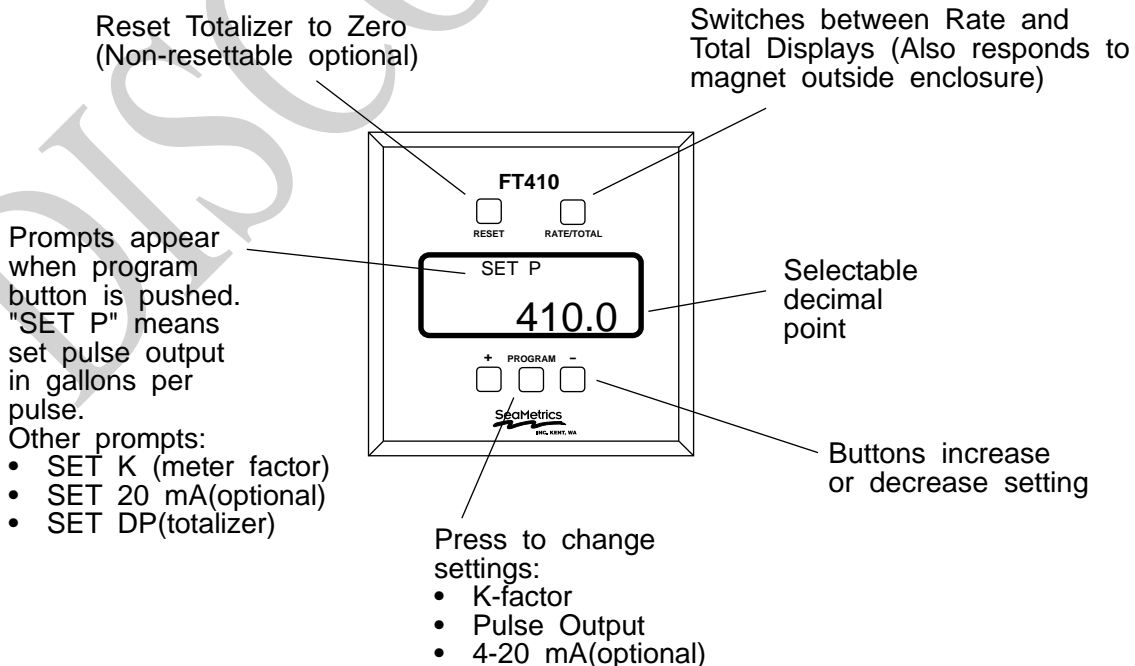

Installation

FT410W: Wall Mounting. Four 3/16" screw holes are located at the bottom of the front cover screw holes. Mark the locations through the holes, then drill. Slip screws down the holes and tighten.

FT410P: Panel Mounting. Use the dimensions on the back page for making the panel cutout. Locate the dovetail mounting bracket grooves on the side and the top of the unit. After cutting out the panel, break any sharp or rough edges, then slip the panel gasket in place behind the FT410 bezel and slide the unit through the panel hole. Install the mounting brackets in their dovetail grooves, with the slots of the clamping screws facing out. Tighten the screws to pull the unit tightly against the panel and compress the gasket slightly.

Connections

FT410M: This unit is pre-wired with 18 ft. of four-conductor cable. See diagram for color coding of the leads. If desired, the cable supplied can be removed, and connections can be made inside the unit, following the Connections diagram.

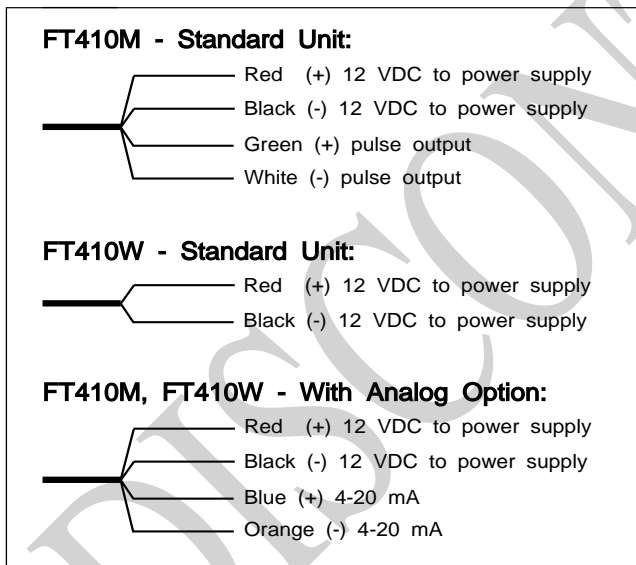

FT410W: This unit is pre-wired with 6 ft. of two-conductor cable for the power connections. See diagram for color coding of the leads. To complete the wiring needed for the application, remove the front clear cover, then remove the front panel to reach the terminals. Turn the front panel over, with the circuit boards still attached. Follow the connections diagram.

Note the polarity of the Pulse Output terminals. Be sure to observe proper polarity when connecting to an electronic metering pump. If the pump does not respond to the pulse output, try switching polarity.

Sensor Out terminals are provided for passing on the signal from a flow sensor to a second electronic device. They do not need to be connected unless using such a device.

FT410P: This unit is ordinarily supplied without pre-wiring. To reach the terminals, remove the four screws which hold the back cover of the housing in place. Follow the connections diagram

Analog Output Board. The optional 4-20 mA output uses a third printed circuit board which plugs into the terminal connection board. This board is pre-wired at the factory with a jumper, so that powering the FT410 automatically provides power to the current loop. If an isolated 4-20 mA output is required (see Connections) it is necessary to remove the jumper and rewire as shown in "Analog Output - Isolated".

Programming



Caution: If pulse output is being used to control an external device, such as a metering pump, do not connect the pulsed device until programming is completed. If malfunction or incorrect programming of the pulse output could cause personal injury or property damage, separate safeguards must be installed to prevent such injury or damage.

Set K-Factor. To begin programming, press the PROGRAM key. The prompt SET K should appear. The K-factor is the number of pulses per volume unit. This number is provided with SeaMetrics meters, in pulses per gallon. If the FT410 is to read in other units, the number provided with the meter must be converted. The FT410 will then totalize in the selected units, and the rate reading will be in those units per minute. The rate is always in units per minute.

To enter the K-factor, press the "+" or "-" keys until the desired number is reached.

Set Pulse Output. Pressing PROGRAM a second time brings up the prompt SET P. This setting controls the pulse output, if it is being used. It is set in units per pulse. For example, if the FT410 is reading in gallons, a setting of 2.00 means that a pulse will occur every 2 gallons. Settings may be as small as 0.1, which means that there is a pulse every 0.1 units. If the optional dry contact pulse output is present, SET P sets that pulse output also. **(NOTE: Pulse output is limited to 100 ppm)**

Standard Connections

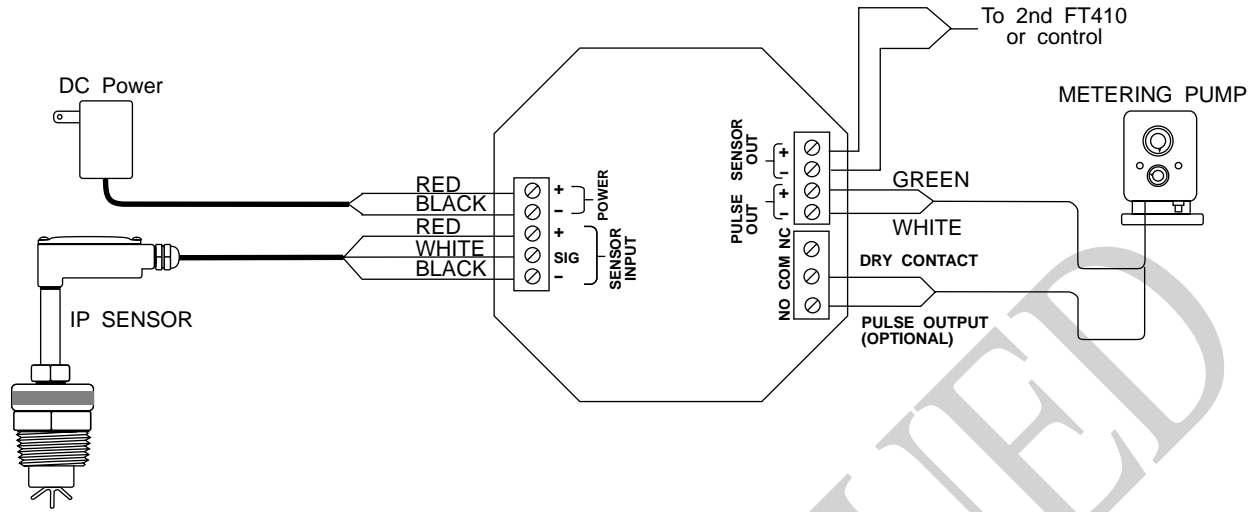

Analog output - Non-Isolated

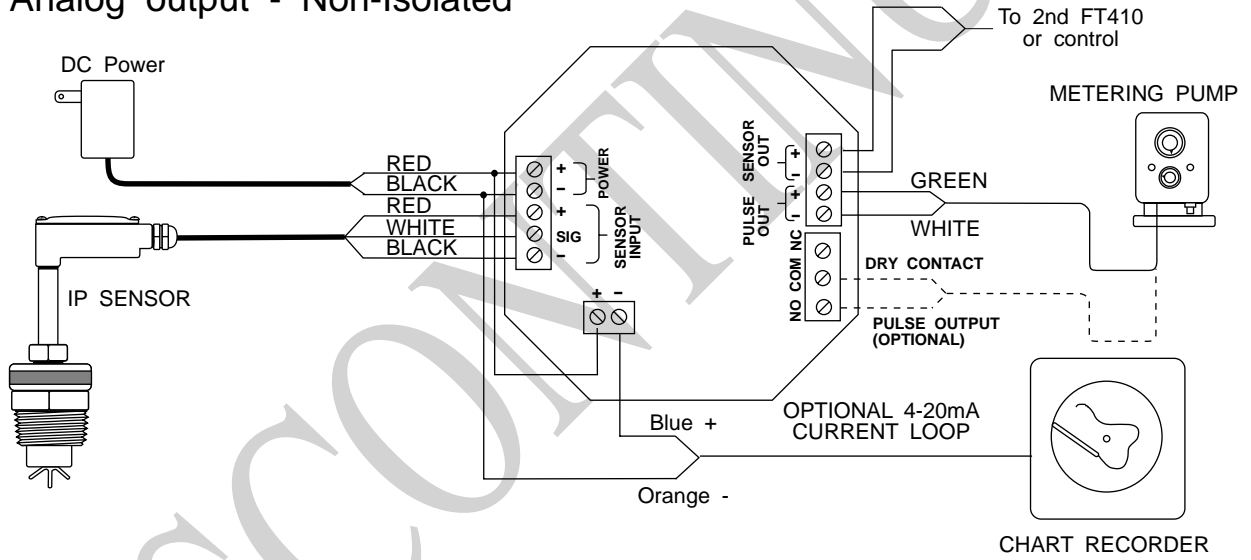

Analog output - Isolated

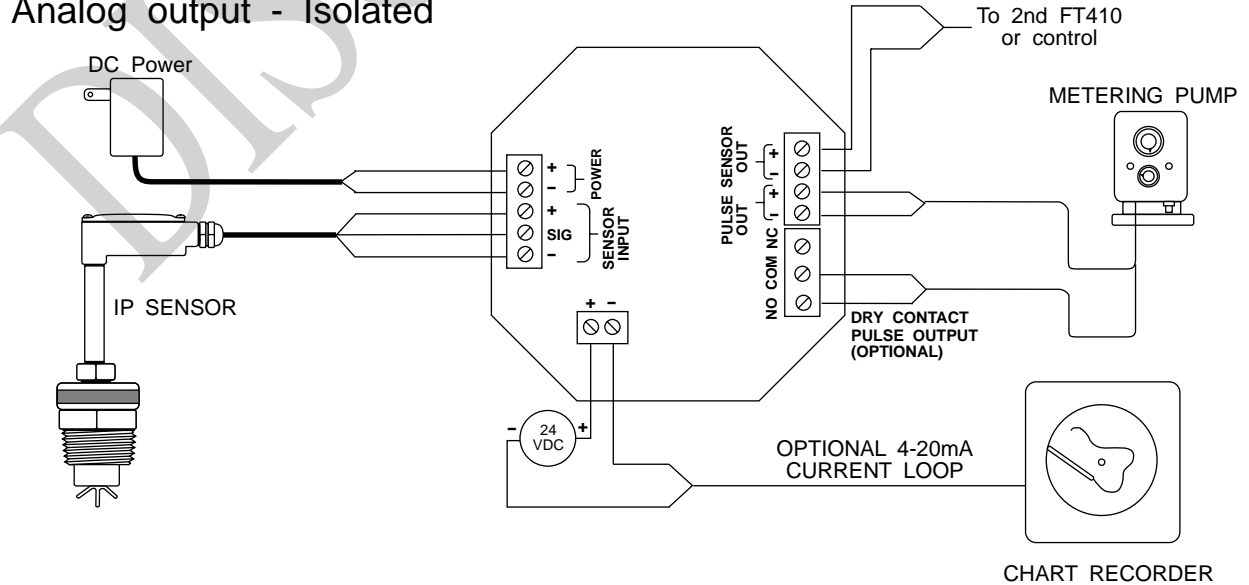

Set 4-20 mA Span. If the optional 4-20 mA board is installed, the prompt SET 20 mA will appear. Set this value to the flow rate, in units per minute, at which the full 20 mA output is desired. Zero flow will automatically be scaled to 4 mA.

Set Decimal Point. Pressing PROGRAM again brings up SET DP. Choices are one decimal place or none. Pressing the +/- keys alternates between the two. Typically, a decimal place is only required with low-flow meters. Exit programming mode. Pressing rate/totalizer button returns unit to operating state.

Operation

In normal operation the FT410 displays rate or total. Pressing RATE/TOTAL alternates from one to the other. This can also be accomplished from outside the unit by touching a magnet to the outside of the case in the general vicinity of the RATE/TOTAL key. When rate is showing, total continues to accumulate. Unless the unit has the NR (non-reset) option, pressing the RESET key sets total to zero. Total is stored in nonvolatile memory and is kept on loss of power, although the unit will not operate during the power outage.

Repair

The only field-repairable component on the FT410 is the fuse. The fuseholder is found on the back of the circuit board stack. Replace with a Littlefuse 3AG 1/2-Amp or equivalent automotive-type fuse.

On units with the 4-20 mA option, it is necessary to remove the analog board at the back of the stack to reach the fuse. Unplug the board by gently tugging on it. On some models, it is also necessary to remove four screws to get the analog board loose.

If failure is due to a cause other than a blown fuse, it is necessary to replace the entire board stack. Contact your distributor for information.

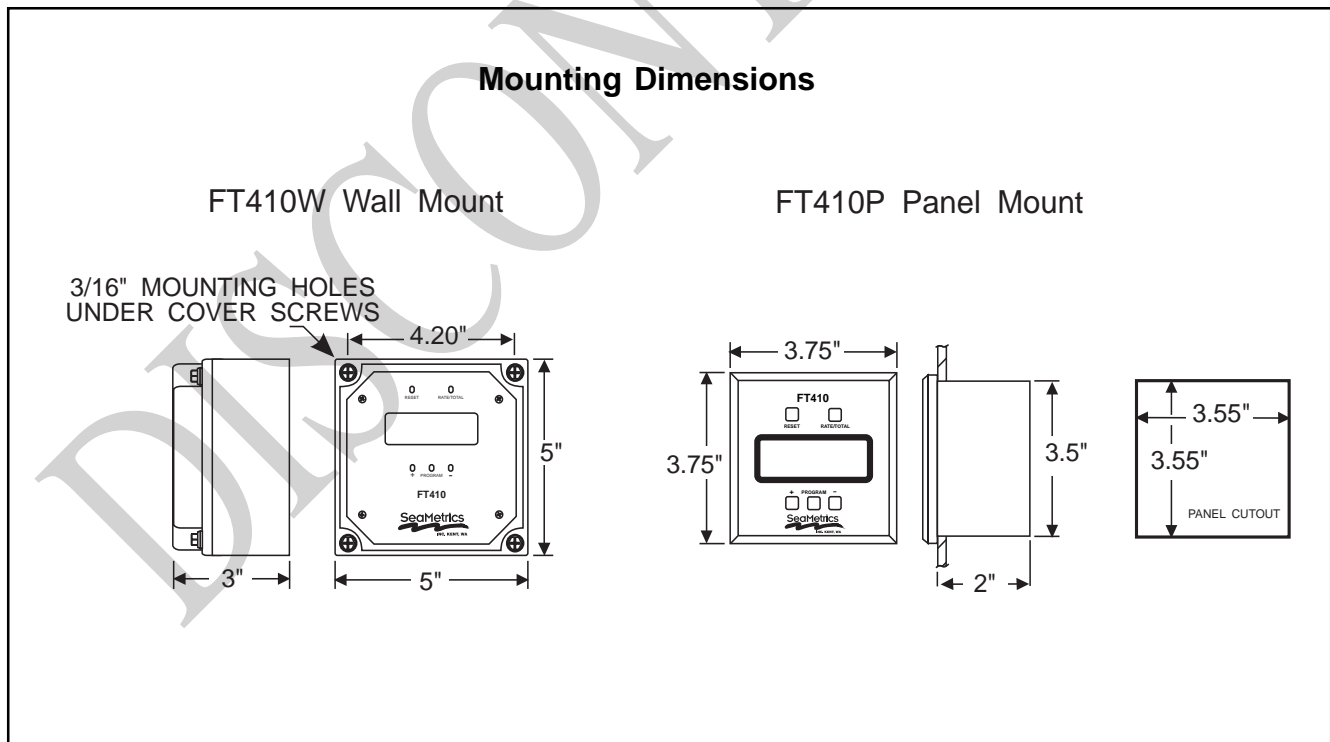

20419 80th Ave. So., Kent WA. 98032 USA
 Phone: 253-872-0284 Fax: 253-872-0285
www.seametrics.com 1-800-975-8153