

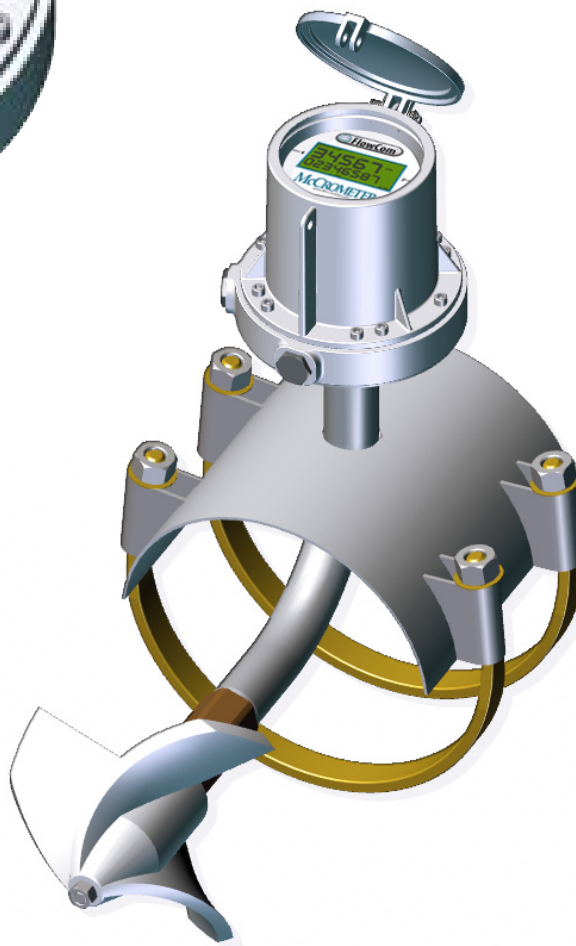

FC100 FlowCom Register

Installation, Operation And Maintenance Manual

24510-29, Rev. 1.9
February 13, 2018



Contents

SAFETY WARNINGS	1
1.0 INTRODUCTION	2
1.1 Description	2
1.2 Features	2
1.3 Model Number Identification	2
2.0 INSTALLATION	3
2.1 Mechanical-to-FlowCom Conversion Kit Installation - Meter Mount	3
2.2 Mechanical-to-FlowCom Conversion Kit Installation - Remote Mount	9
3.0 OUTPUT WIRING CONNECTION	12
3.1 Wiring Diagrams	12
3.2 4-20mA Test Modes	15
3.3 LCD Output Symbol Clarifications	16
4.0 PROGRAMMING	17
4.1 Accessing The Configuration Menu	17
4.2 Document Changes	17
4.3 Menu Table Of Contents	18
4.4 Menu Navigation	19
4.5 Configuration Examples	29
5.0 PRODUCT SPECIFICATIONS	32
5.1 Features and Specifications	32
5.2 Dimensions	33
5.3 Housing	33
5.4 Parts List	34
6.0 PRODUCT MAINTENANCE	35
6.1 Battery Replacement	35
7.0 TROUBLESHOOTING	36
7.1 Circuit Board Connections	37
WARRANTY STATEMENT	38

SAFETY WARNINGS

When installing, operating, and maintaining McCrometer equipment where hazards may be present, you must protect yourself by wearing Personal Protective Equipment (PPE) and be trained to enter confined spaces. Examples of confined spaces are manholes, pumping stations, pipelines, pits, septic tanks, sewage digesters, vaults, degreasers, storage tanks, boilers, and furnaces.

You must follow all state and local laws, as well as Occupational Health and Safety Administration (OSHA) regulations concerning Personal Protective Equipment, confined-space entry, and exposure to bloodborne pathogens. Specific requirements can be found in the OSHA section of the Code of Federal Regulations: *29 CFR, 1910.132 - 1910.140, Personal Protective Equipment; CFR Title 29, Part 1910.146, Permit-Required Confined-Spaces; and 29 CFR, 1910.1030, Bloodborne Pathogens.*



WARNING!

Never enter a confined space without first testing the air at the top, middle, and bottom of the space. The air may be toxic, oxygen deficient, or explosive. Do not trust your senses to determine if the air is safe. You cannot see or smell many toxic gases.



WARNING!

Never enter a confined space without the proper safety equipment. You may need a respirator, gas detector, tripod, lifeline, and other safety equipment.



WARNING!

Never enter a confined space without standby/rescue personnel within earshot. Standby/rescue personnel must know what action to take in case of an emergency.



WARNING!

Pressurized pipes should only be tapped, cut, or drilled by qualified personnel. If possible, depressurize and drain the pipe before attempting any installation.

1.0 INTRODUCTION

1.1 Description

The FlowCom Register displays a flowmeter's flowrate and volumetric total. Available are optional outputs: scaled pulse and/or industry standard 4-20mA signal. The FlowCom can be fitted to any new or existing McCrometer propeller flowmeter.

1.2 Features

- Retrofits to any existing McCrometer Mc Propeller Flowmeter
- Four output options: Contact Closure, Open Collector, Optically Isolated, and 4-20mA Loop
- Unique Units of Measurement for Rate, Total, 4-20mA and Pulse Outputs
- 6–10 Year Battery Life
- NEMA 4X Enclosure with Non-intrusive Register Programming
- Remote and Meter-Mounted Models
- Factory sealed enclosure protects electronics

1.3 Model Number Identification

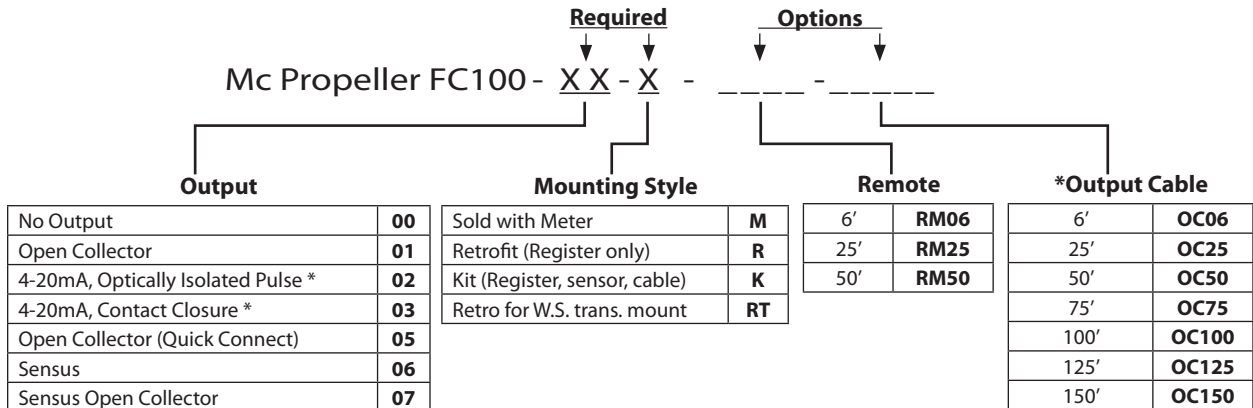

*Output Cable Option is ONLY available with Outputs of 01, 02 or 03.

*These output options require 420mA/DC power.

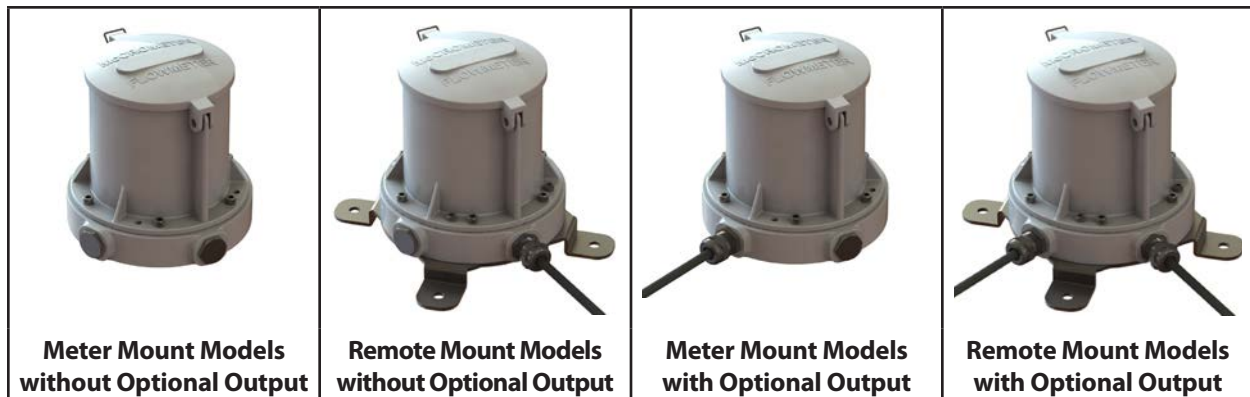

2.0 INSTALLATION

After unpacking the register assembly, verify that the meter serial number engraved on the enclosure lid is correct. Then confirm the information on a white label located on the side of the base plate (Figure 1).

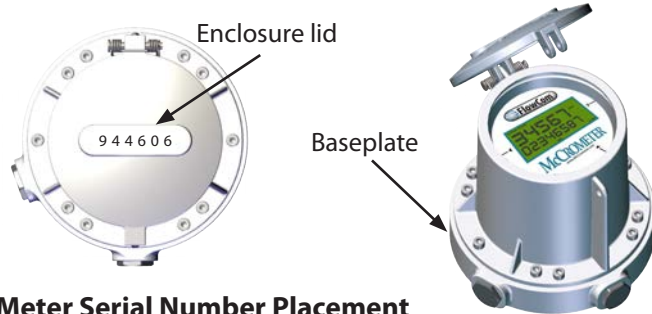

Figure 1. Meter Serial Number Placement

2.1 Mechanical-to-FlowCom Conversion Kit Installation - Meter Mount

Note: For remote mount retrofit, see section 2.2.

Check the parts received against the parts list and Figure 2 and Figure 3. Contact the factory to report any discrepancies.



Figure 2. Conversion Kit - FC100-00-K, Meter Mount

Parts Diagram	Description	Quantity	Part Number
1	FlowCom Unit	1	FC100-01
2	O-Ring (243 Buna)	1	1-1551-38
3	Mounting Plate	1	R0138-10
4	Screw 10-32 x 1.25" Long	2	10730
5	Screw 10-32 x 1.25" Long w/hole	2	10830
6	Bushing and O-Ring Assembly:		
6.1	Bushing	1	R0142-00
6.2	O-Ring (021 Buna)	1	10273
6.3	O-Ring (121 Buna)	1	10274
7	Gasket	1	10023-00
8	O-Ring (024 Buna)	2	10110-10
9	Magnet Wand	2	FC100-M
10	Sensor	1	EA530-00

INSTALLATION

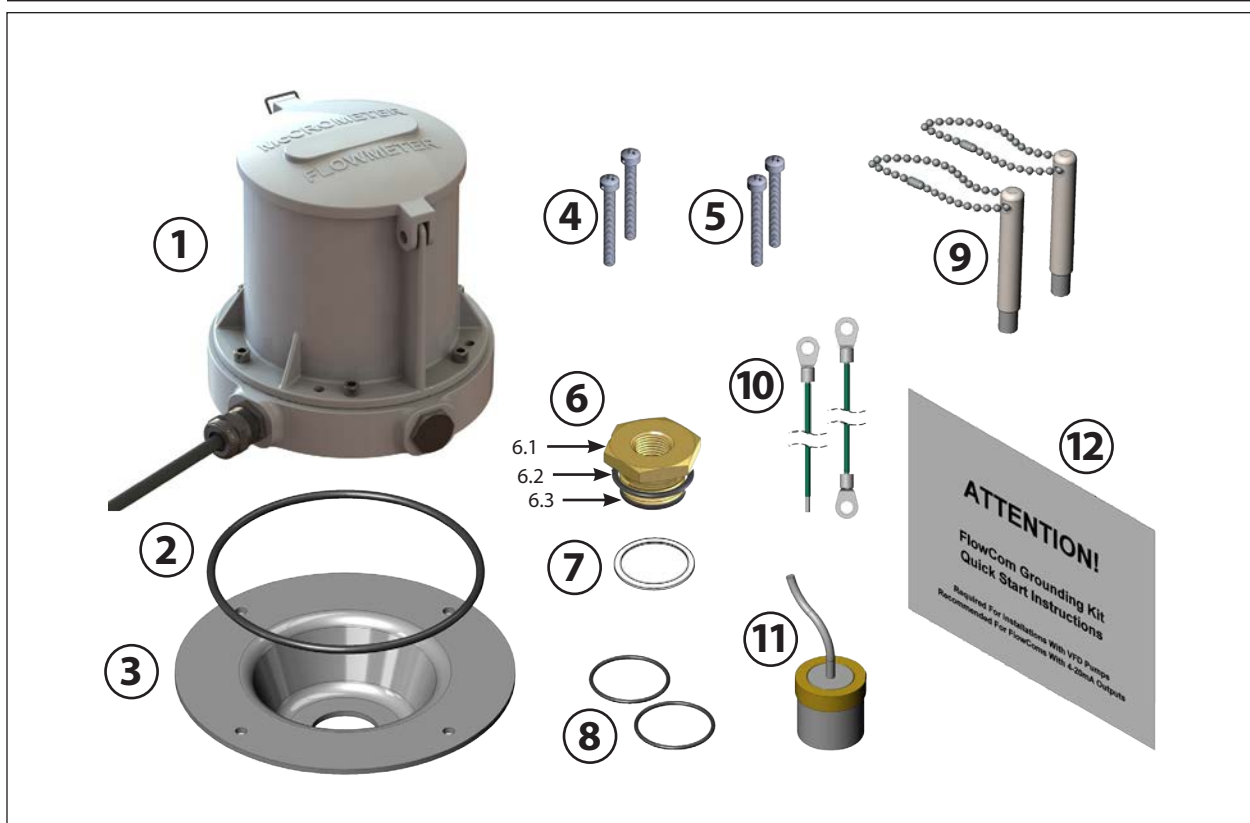

Figure 3. Conversion Kit - FC100-01-K, FC100-02-K, FC100-03-K, Meter Mount

Parts Diagram	Description	Quantity	Part Number
1	FlowCom Unit	1	FC100-01
2	O-Ring (243 Buna)	1	1-1551-38
3	Mounting Plate	1	R0138-10
4	Screw 10-32 x 1.25" Long	2	10730
5	Screw 10-32 x 1.25" Long w/hole	2	10830
6	Bushing and O-Ring Assembly:		
6.1	Bushing	1	R0142-00
6.2	O-Ring (021 Buna)	1	10273
6.3	O-Ring (121 Buna)	1	10274
7	Gasket	1	10023-00
8	O-Ring (024 Buna)	2	10110-10
9	Magnet Wand	2	FC100-M
10	Green Wire	2	1-1706-18-1
11	Sensor	1	EA530-00
12	Grounding Kit Instructions	1	24517-08

STEP 1: Remove the flowmeter.

Remove pressure from the pipeline.

Remove the entire flowmeter from the pipeline.



CAUTION! Never remove a meter or top plate assembly while the line is under pressure!

STEP 2: Remove the mechanical register and base plate

- Remove the six screws around the base.
- Lift up and remove the canopy.
- Loosen the pal nut (10019-00) from the base plate.
- Unscrew and remove the register.
- Unscrew and remove the pal nut (10019-00) from register.
- Unscrew and remove the brass bushing (R0142-00) from the base plate.
- Lift up and remove the base plate from ell bracket.

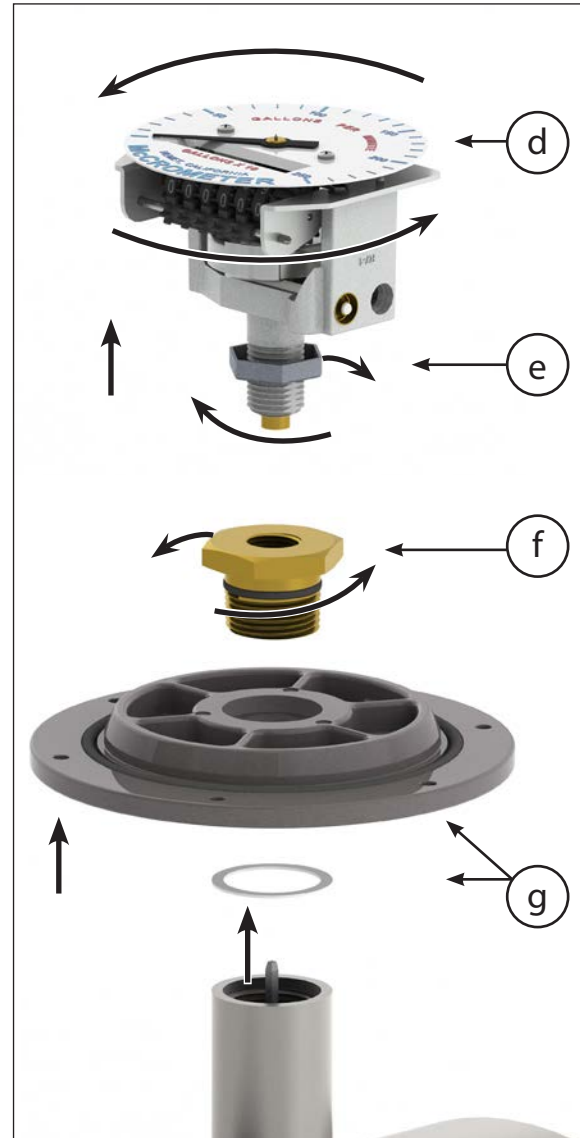

STEP 3: Disassemble the flow meter

Meters with a saddle or top plate assembly:

- Remove the meter assembly from the tube.
- Unsecrew the bearing assembly (with propeller attached) from the ell using a 1-3/8" wrench.

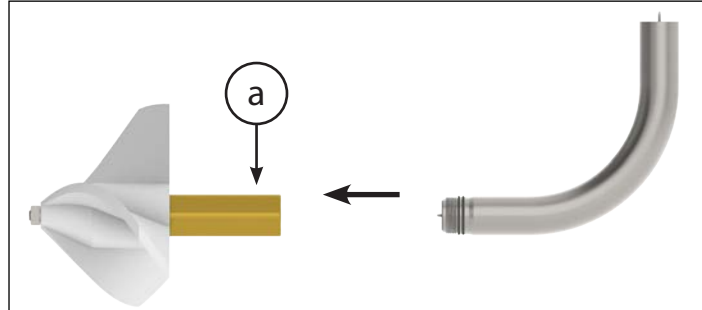

Meters with a fixed ell:

- Remove the nut holding the propeller onto the bearing shaft using a 9/16" nut driver.
- Pull the propeller from the bearing shaft. **NOTE:** The propeller is locked into place with a small metal "key". This key will loosen when the propeller is removed. Retain this key with the propeller.
- Remove the bearing assembly using a 1-3/8" bearing socket (McCrometer part number T-23).

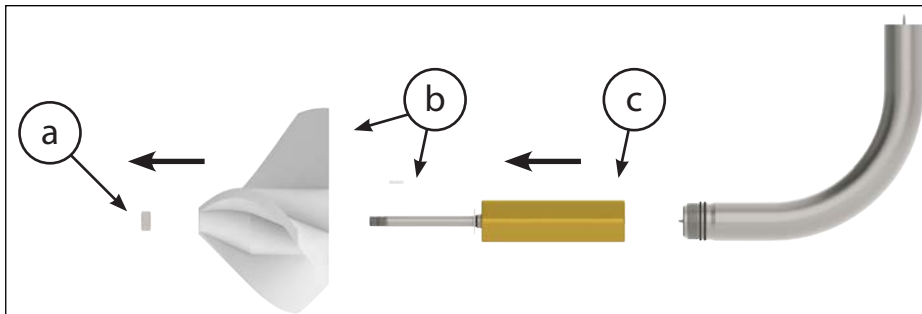

All meter types:

- Remove the two O-rings from the threaded end of the ell.
- Remove the drive cable, liner stop and the liner from the ell.

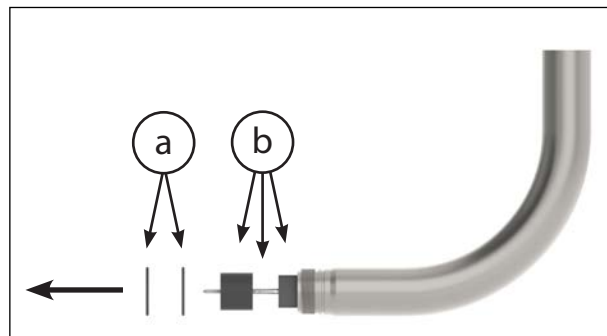

INSTALLATION

STEP 4: Reassemble the flow meter

- a. Remove the aft bearing from the bearing assembly. Simply pull out the aft bearing as it is only held in place by magnetic attraction.
- b. Set the sensor into the back of the bearing housing. Be sure the sensor is fully seated into the bearing housing before re-installing the bearing assembly onto the ell. NOTE: Ensure the bearing housing and sensor are clean and free of any debris or dirt. Any debris or dirt may cause difficulty in removing the sensor in the future.

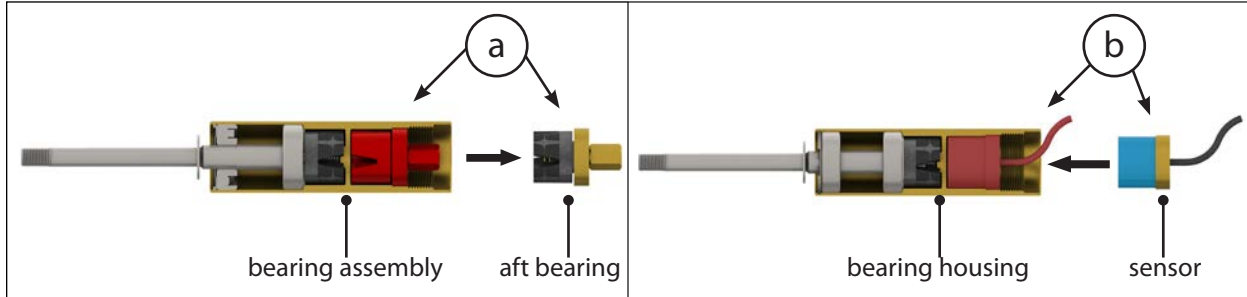

- c. Install new O-rings onto the two grooves just behind the threads at the end of the ell. NOTE: it is recommended to use a silicone grease on the new O-rings to assist with sealing.
- d. Push the sensor cable up through the ell.
- e. Install and tighten the bearing assembly.
- f. Place the propeller on the end of the shaft and attach it to the bearing assembly with a 9/16" nut.

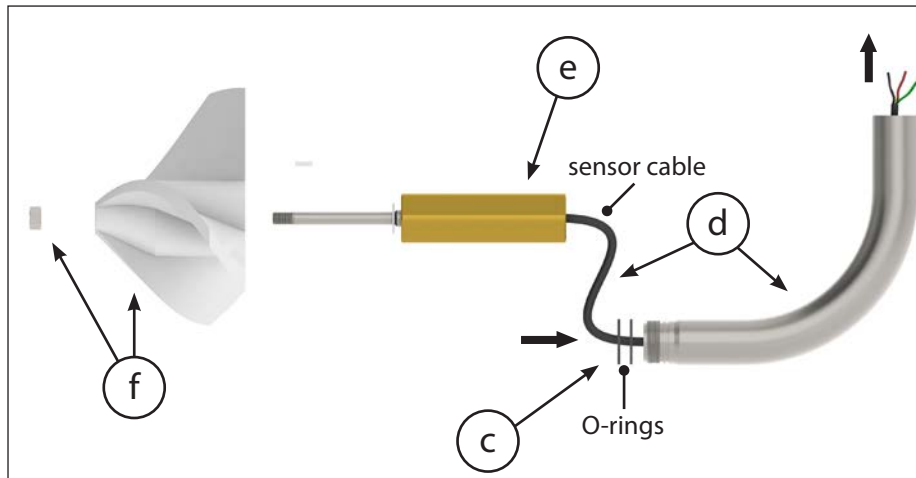

STEP 5: Connect the wiring and attach the FlowCom

- a. Feed the sensor cable through the gasket, the base plate, and the hex bushing with O-rings.
- b. Secure the assembly by screwing the hex bushing into the ell.

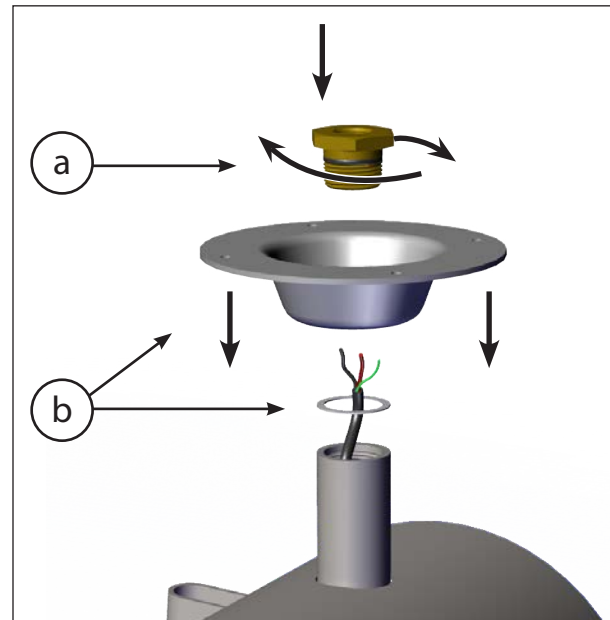

INSTALLATION

- c. Connect the sensor wire to the inline terminal block.
- d. Connect the cable from the FlowCom to the inline terminal block matching the the red, black, and green wires.
- e. Attach the FlowCom onto the mounting plate with the provided screws. **NOTE:** If using existing sensor, make sure the shield wire and common (black) are not connected.

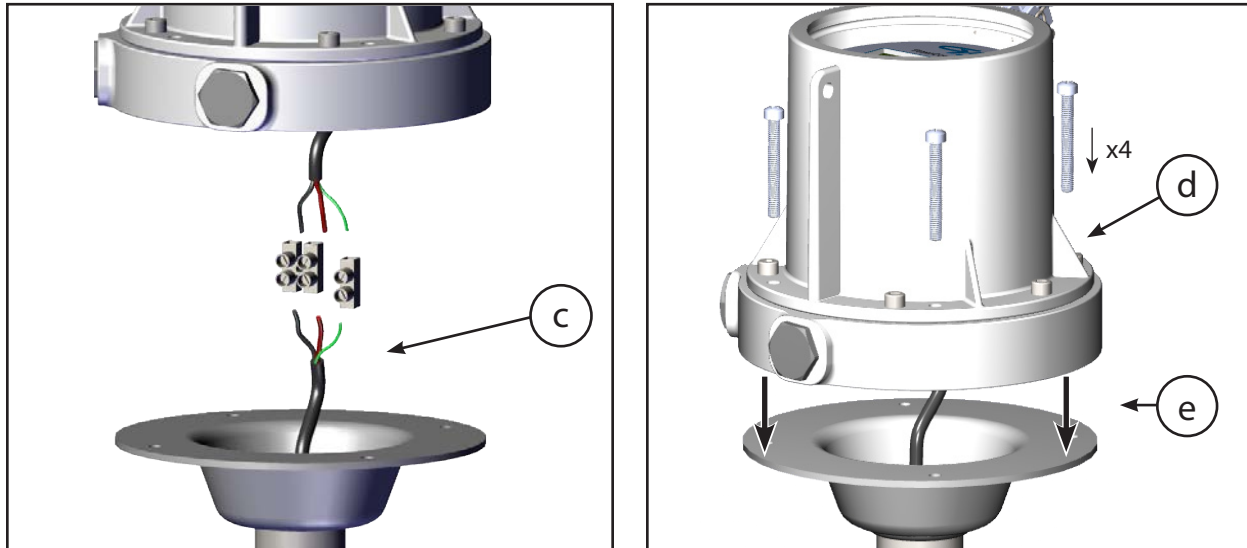

NOTE: When the FlowCom is attached to the base plate, it can be oriented in four possible ways. This affects how the register is read when the flowmeter is installed in the pipe. Select the orientation you prefer as shown below in Figure 4.

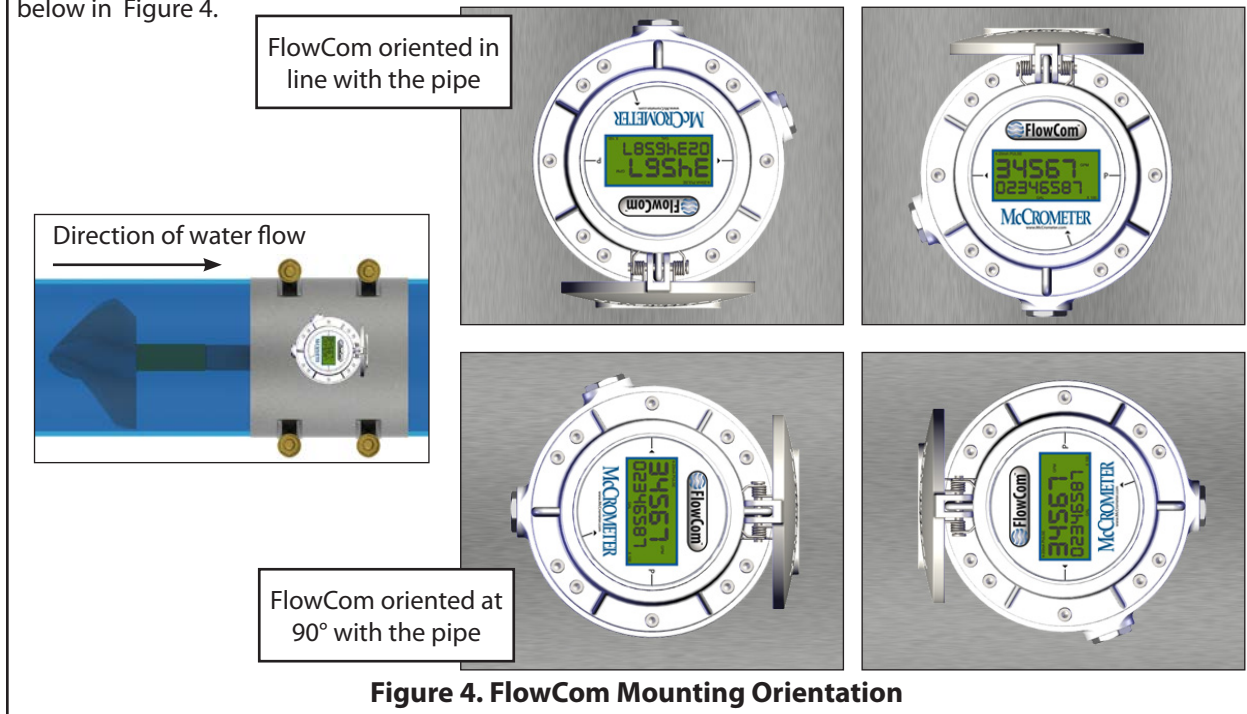

Figure 4. FlowCom Mounting Orientation

STEP 6: Test the FlowCom

Reassemble the propeller onto the bearing assembly. To test the conversion, spin the propeller by hand and ensure the display on the FlowCom indicates flow, then install the meter back into the line.

2.2 Mechanical-to-FlowCom Conversion Kit Installation - Remote Mount

Check the parts received against the parts list below. Contact the factory to report any discrepancies.

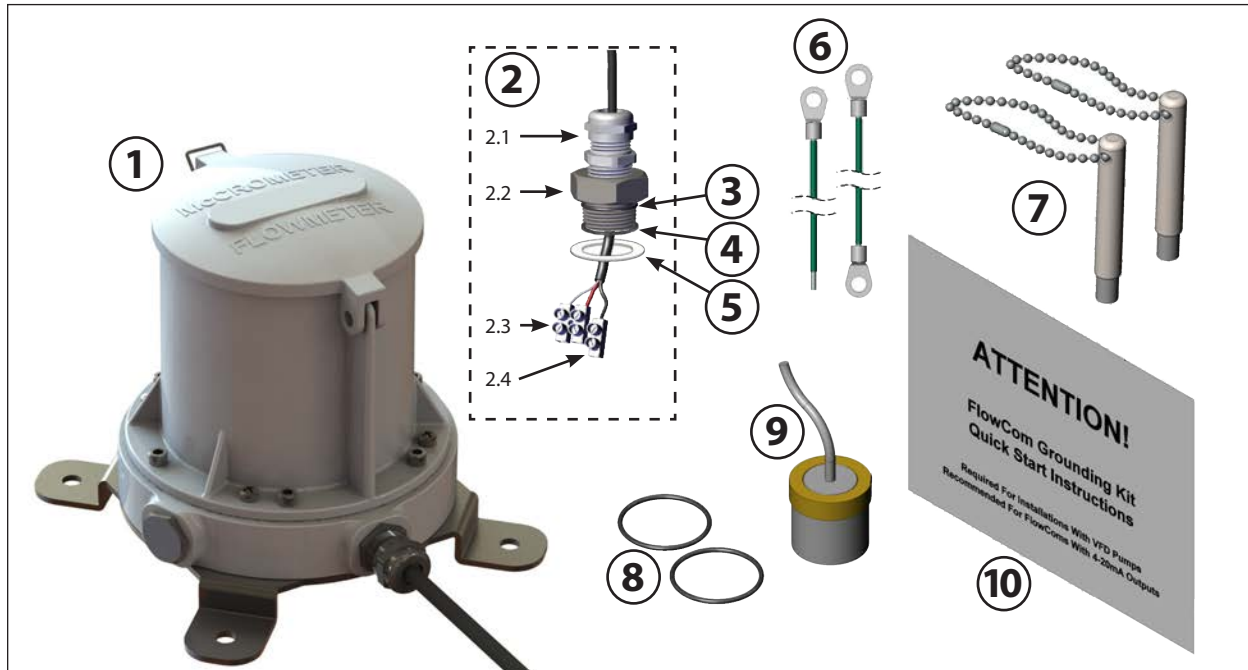

Figure 5. Conversion Kit - FC100-00-R, FC100-01-R, FC100-03-R with Remote Mount

Parts Diagram	Description	Quantity	Part Number
1	<i>FlowCom unit assembly, consisting of:</i>	1	FC100-XX
	O-Ring (243 Buna)	1	1-1551-38
	Screw 10-32 x 1.25" Long	2	10730
	Screw 10-32 x 1.25" Long w/hole	2	10830
	Wall Mount Bracket	1	1-2802
2	<i>Submersible Remote Mount Kit, consisting of:</i>	1	R0139-00-K
2.1	Cable Fitting PG11	2	EJ543-00
2.2	K adapter for PG11 fitting S316	1	R0139-00
2.3	Inline Terminal 2 Position	1	1-1707-19
2.4	Inline Terminal 1 Position	1	1-1707-18
3	O-Ring (021 Buna)	1	10273
4	O-Ring (121 Buna)	1	10274
5	Gasket	1	10023-00
6	Green Wire	1	1-1706-18-1
7	Magnet Wand	2	FC100-M
8	O-Ring (024 Buna)	2	10110-10
9	Sensor	1	EA530-00
10	Grounding Kit Instructions	1	24517-08

STEP 1: Install submersible remote mount kit in the meter head

Use Figure 6 at right as a guide for this step.

- a. Follow steps 1 through 4 from section 2.1.
- b. Pull the FlowCom remote cable through the assembled submersible remote mount kit and out through the bottom.
- c. Using the inline terminal, connect the FlowCom remote cable to the sensor cable wires, matching the red wires and the black wires.
- d. Guide the inline terminal block into the neck of the ell and screw the submersible remote mount kit assembly into the neck of the ell while holding the remote mount cable. Holding the remote mount cable will prevent the twisting of the sensor cable inside the ell which can cause the cable termination of the inline terminal block to be pulled apart.
- e. Tighten down the compression on the submersible assembly kit. Tighten only hand tight plus one half turn.

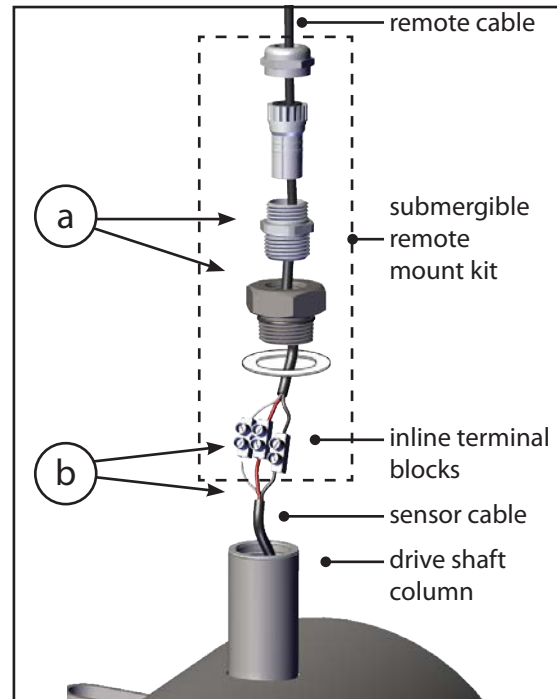

Figure 6. Submersible Remote Mount Assembly



WARNING!

Over tightening the cable compression seal will damage the internal conductors, causing them to be crushed and shorted together, preventing proper operation.

INSTALLATION

STEP 2: Test the FlowCom.

Test the conversion by spinning the propeller by hand and ensuring the display changes. Install the meter into the line and mount the remote FlowCom in a convenient location.

STEP 3: Ground the Flowcom.

Following the Grounding Kit Instructions, connect the ground wire to the Flowcom and other systems that may be attached.



NOTE: Figure 7 shows grounding required for installations with VFD pumps and recommended for FlowComs with 4-20mA outputs.

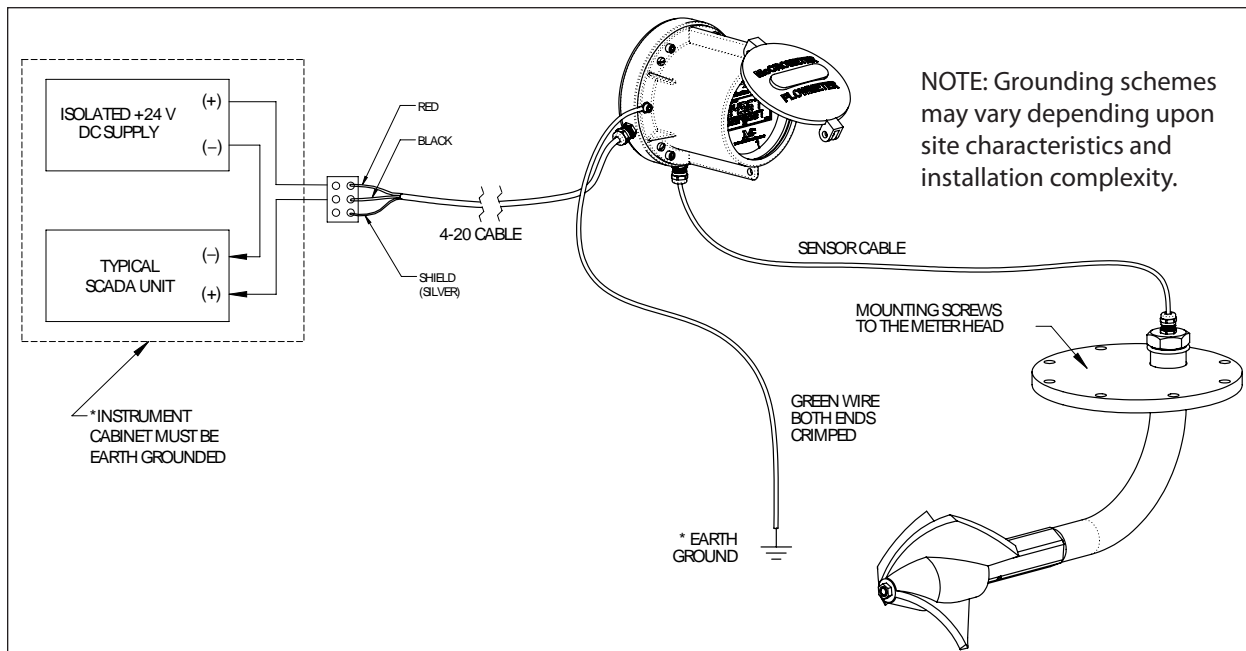

Figure 7. Grounding the FlowCom Remote Mount

OUTPUT WIRING CONNECTION

3.0 OUTPUT WIRING CONNECTION

3.1 Wiring Diagrams

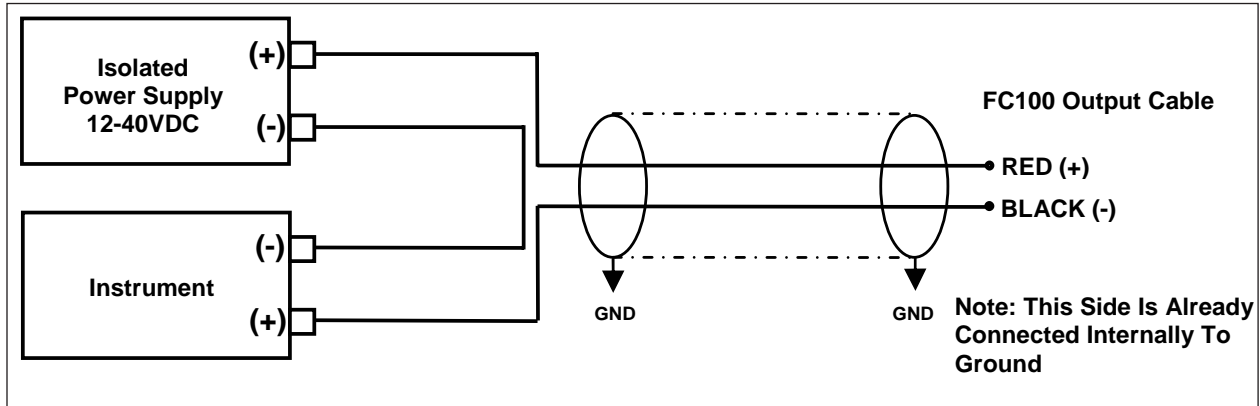

Figure 8. Output Type 4-20mA Current Loop (Meter-mounted version)

Housing Label:1 (Figure 10)

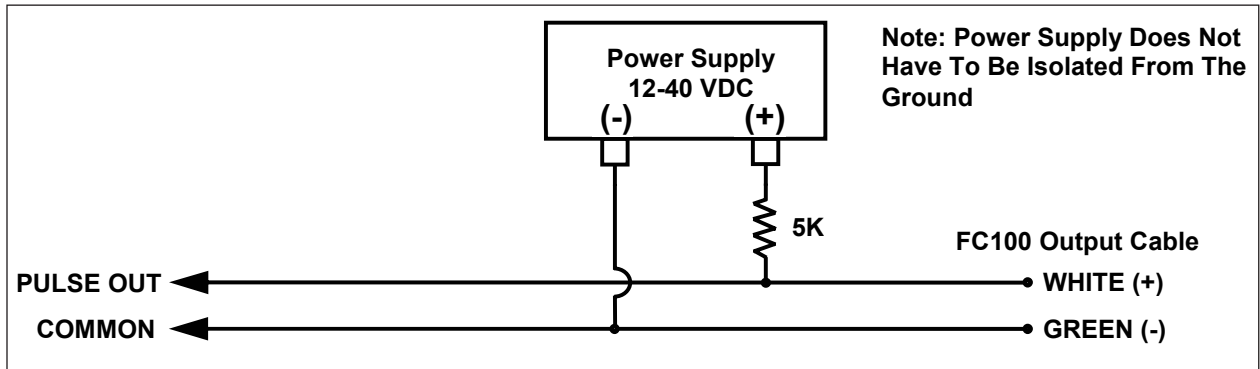

Figure 9. Output Type Optically Isolated Connection

Housing Label: 1 (Figure 10)

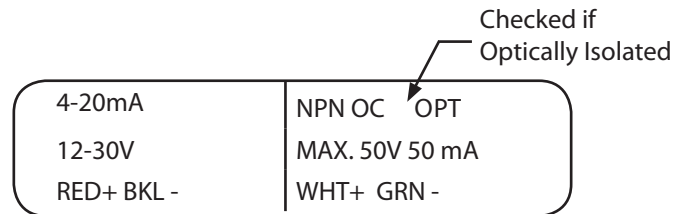

Figure 10. Housing Label 1

"4-20mA / OC"

OUTPUT WIRING CONNECTION

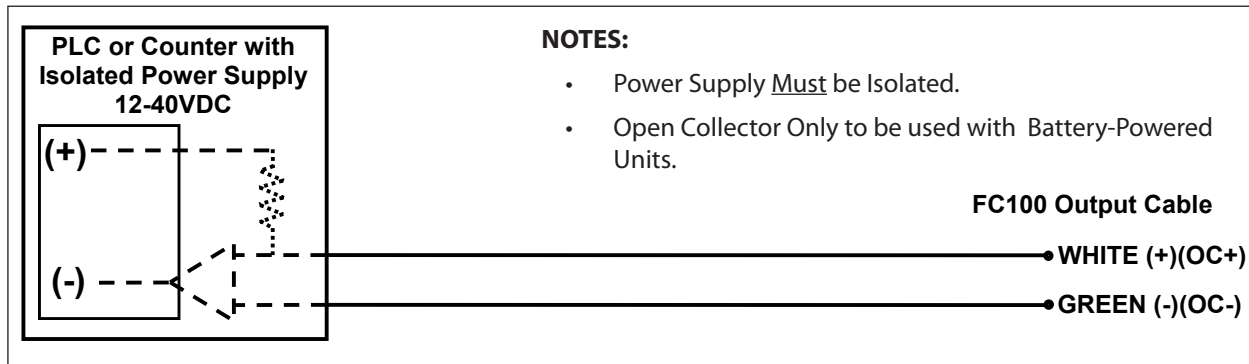
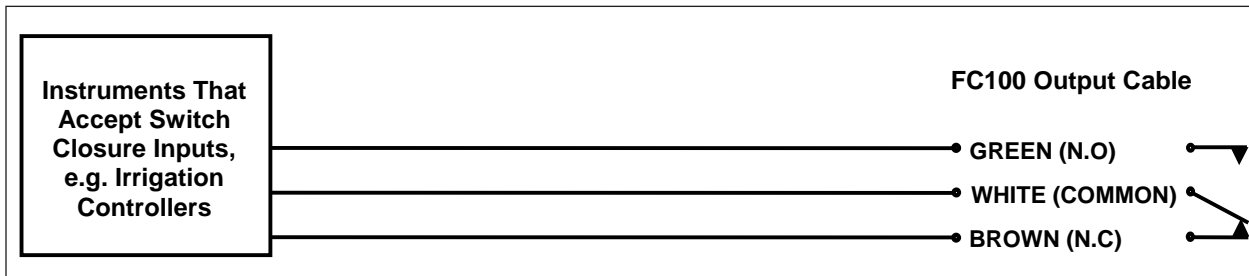

Figure 11. Output Type Open Collector Powered by Instrument with Internal Resistor
Housing Label: 2 (Figure 13)



NOTE: 4-20mA loop must be powered to function.

Figure 12. Output Type Dry Contact Switch Closure
Housing Label: 2 (Figure 13)

4-20mA	RELAY MAX. 30V 1A
12-30V	WHT - COMMON
RED+ BKL -	GRN - NO BRN - NC

Figure 13. Housing Label 2
"4-20mA / Switch Closure"

OUTPUT WIRING CONNECTION

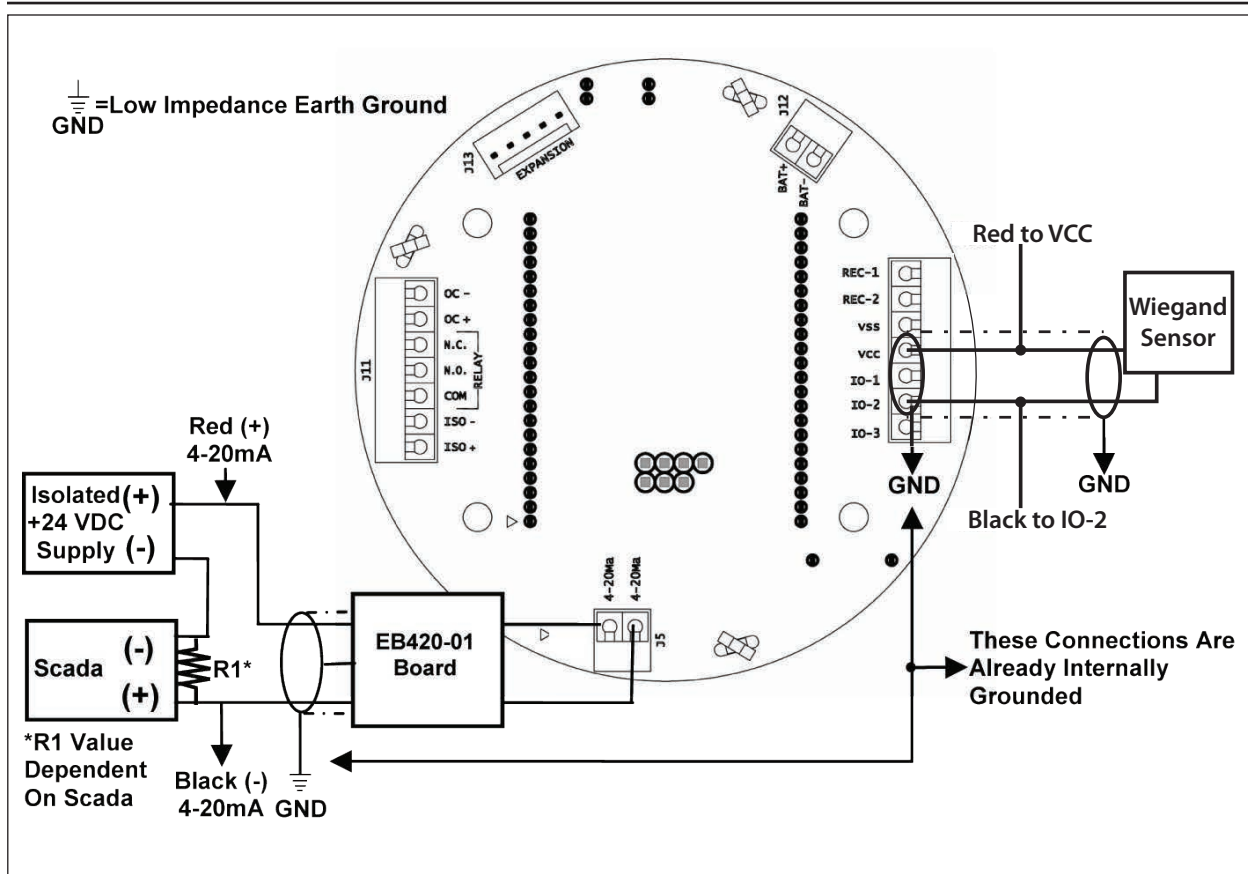

**Figure 14. Output Type 4-20mA Current Loop (Remote-mounted version)
In The Presence Of Environmental Noise (VFDs, RF Transmitters, etc.)**

***IMPORTANT: SEE NOTES**

Housing Label: 1 (Figure 10)

***IMPORTANT NOTES:** 4-20mA Current Loop In Presence Of Environmental Noise (VFDs, RF Transmitters etc.)

- The +24VDC Power Supply must be isolated by ensuring that the -24VDC is NOT tied to earth ground
- To ensure that the power supply for 4-20mA output loop is properly isolated from the earth ground, check voltage between earth ground and negative power supply terminal. You should see floating values, in approximate range of 4V to 8V.
- The shield for the Wiegand sensor must be connected to earth ground. Ensure the shield for the sensor is not connected to VSS.
- To locate good earth ground, measure impedance between any of the non-powered 4-20mA terminals and the chosen ground spot. The ohmmeter should show a very low reading, lower than 1Ω.

OUTPUT WIRING CONNECTION

3.2 4-20mA Test Modes

Whether or not there is flow in the pipeline, the 4-20mA output can be tested to confirm that the wiring interconnections are connected properly. Refer to Figure 15 for the following instructions.

- To output 4mA, use two magnetic wands to activate the left and lower triangles simultaneously.
NOTE: The display will briefly show the software version, e.g., sw 2.3.
- To output 20mA, use two magnetic wands to activate the left triangle and the right **P** simultaneously.
NOTE: The display will briefly show the software version, e.g., sw 2.3.
- Individually select any triangle or P to exit the test mode.



Figure 15. Typical FC100 Face

OUTPUT WIRING CONNECTION

3.3 LCD Output Symbol Clarifications

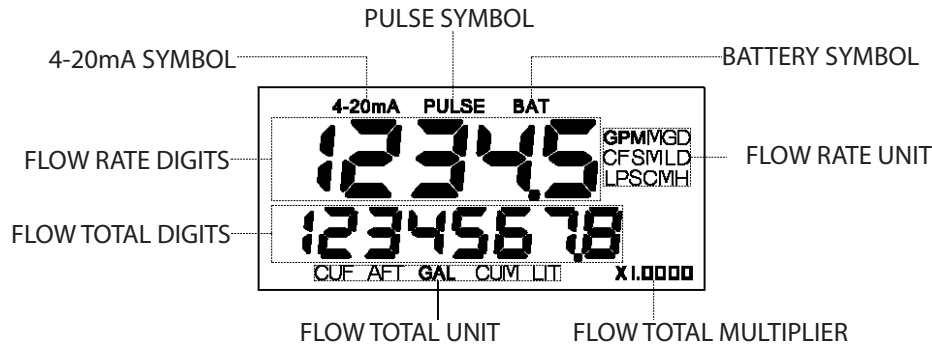

Figure 16. FC100 Screen Symbols

SCENARIO	RESULT
The 4-20mA full scale is not defined and the 4-20mA loop is either powered or not powered.	There is no 4-20mA output and the "4-20mA" symbol is <i>off</i> .
The 4-20mA full scale is defined and the 4-20mA loop is powered.	There is a 4-20mA output and the "4-20mA" symbol is <i>on</i> .
The 4-20mA full scale is defined and the 4-20mA loop is powered, but the output value is over 21.5mA.	There is a 4-20mA output and the "4-20mA" symbol is <i>flashing</i> .
The pulse increment value is not defined.	There is no pulse output and the "PULSE" symbol is <i>off</i> .
The 4-20mA loop is not powered, the pulse increment value is defined and the pulse type is set as an optically-isolated open collector or a relay switch.	There is no pulse output and the "PULSE" symbol is <i>flashing</i> .
The 4-20mA loop is not powered, the pulse increment value is defined and the pulse type is set as an open collector.	There is a pulse output and the "PULSE" symbol is <i>on</i> .
The 4-20mA loop is powered, the pulse increment value is defined and the pulse type is set as an optically-isolated open collector or a relay switch.	There is a pulse output and the "PULSE" symbol is <i>on</i> .
The 4-20mA loop is powered, the pulse increment value is defined and the pulse type is set as an optically-isolated open collector or a relay switch, but the output frequency is greater than the limit of the selected pulse type.	There is a pulse output and the "PULSE" symbol is <i>flashing</i> .
The battery level is ok.	The "BAT" symbol is <i>off</i> .
The 4-20mA loop is either powered or not powered, and battery level meets low battery criteria.	The "BAT" symbol is <i>on</i> .

4.0 PROGRAMMING

4.1 Accessing The Configuration Menu

Hold the magnetic wand as noted in Figure 17 below. After five seconds the register will display "Loc-Code". **A lock code of 01000 is required to enter the configuration menu.** Use the magnetic wand to input the lock code and then pass the wand over the "P" symbol to submit the lock code and the configuration menu will appear. The register will switch back to run mode by either selecting the run mode from the configuration menu or by not activating the configuration menu for sixty seconds.

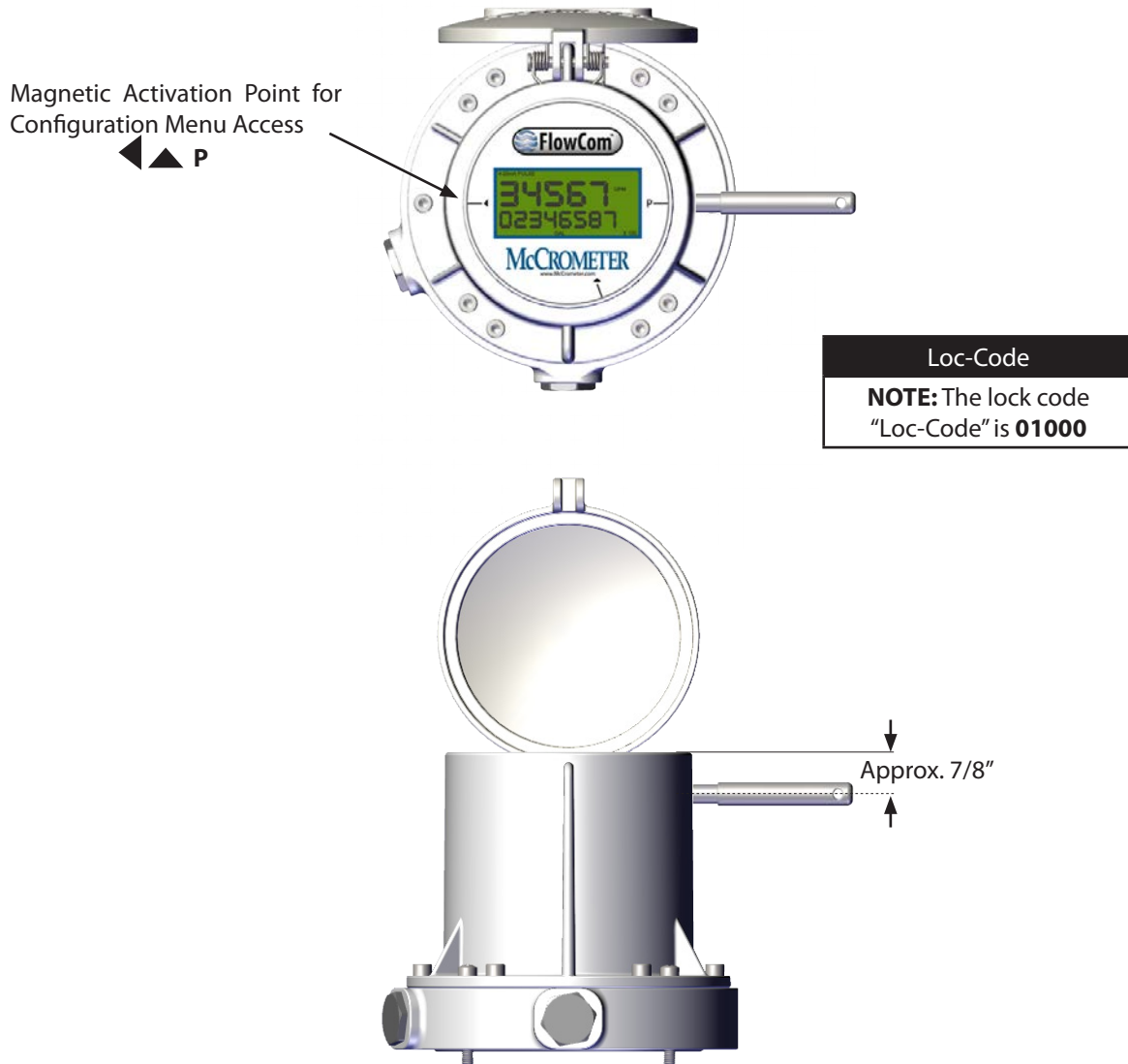

Figure 17. Magnetic Wand Activation Points For Configuration Menu

4.2 Document Changes

Each register ships with two silver identification labels. The label contains basic setting information for the register. If changes are made to the register settings the labels should be marked as required. Forward the changes to the factory so the records can be updated.

4.3 Menu Table Of Contents

First Menu Level			
Display	Menu Title	Description	
0	Loc-CodE	Program Lock Out	Enter w/preset code
1	rAtE-Un	Rate Unit/Time	Sets Unit/Time
2	rAtE-dP	Rate Format	Sets Rate Decimal Place
3	tot-Un	Totalizer Unit	Sets Unit
4	tot-dP-E *	Totalizer Decimal Point Enable	Enables/Disables Totalizer Decimal Point
5	tot-dP *	Totalizer Decimal Place	Sets Decimal Place
	Tot-FAct *	Totalizer Multiplier	Sets Multiplier
6	20mA-Un	20mA Unit	Sets 20mA Unit
7	20mA-dP	20mA DP	Sets 20mA Decimal Place
8	20mA-FS	20mA FS	20mA Full Scale
9	PLS-Un	Pulse Unit	Sets Pulse Unit
10	PLS-dP	Pulse Decimal Place	Sets Pulse Decimal Place
11	PLS-Inc	Pulse Increment	Sets Pulse Value
12	CAL-Pct	Calibration Percent	Adjusts Meter Accuracy
13	-Go to	Go to Menu or Run	

Second Menu Level			
Display	Menu Title	Description	
1	Par-S	Parent Meter Serial #	Sets Meter Serial No.
2	SErno	Register Serial #	Sets Register Serial No.
3	Set-CodE	Set Lock Code	Sets new Lock Code
4	GPr-dP	GPR Decimal Place	Sets GPR Decimal Place
5	GPr	Gallons Per Revolution	Sets GRR Digits
6	Smooth	Smoothing	Turns Smoothing on/off
7	4mA-AdJ	Trim 4mA	Adjusts 4mA Zero
8	20mA-AdJ	Trim 20mA	Adjusts 20mA FS
9	PLS-tYPE	Pulse Type	Sets Pulse Type
10	PLSwidth **	Pulse Width	Sets Pulse Width in ms
11	RESEttot	Reset Total	Zeroes Total
12	DIS-rSt	Disable Reset Total	Permanent Reset Disable
13	tot-S	Set Total	Sets Total
14	Au-InP	Auxiliary Input	Sets operation of input
15	cutoff	Low Flow Cutoff	Sets Min. Flowrate
16	PLS-Pr	Pulses per Revolution	Sensor Pulses per rev.
17	-Go to	Go to Menu or Run	

* If **tot-dP-E** (Totalizer Decimal Point Enable) is disabled (turned off), **tot-dP** (Totalizer Decimal Place) will not be accessible.

* If **tot-dP-E** (Totalizer Decimal Point Enable) is enabled (turned on), **Tot-FAct** (Totalizer Multiplier) will not be accessible.

** **PLSwidth** (Pulse Width) is only accessible when **OC** is selected in the **PLS-tYPE** menu (Pulse Type).

4.4 Menu Navigation

First Menu Level	
0	Loc-CodE

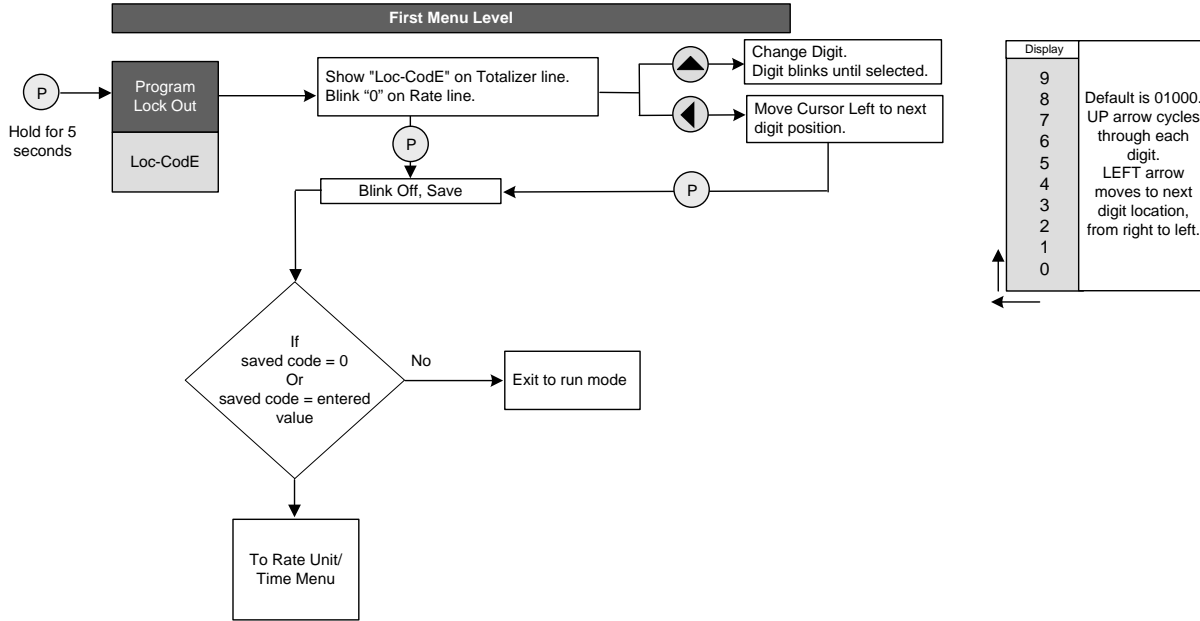
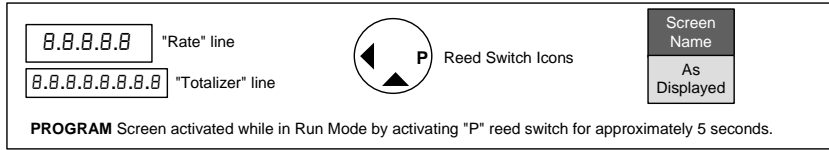

Display	
9	Default is 01000. UP arrow cycles through each digit. LEFT arrow moves to next digit location, from right to left.
8	
7	
6	
5	
4	
3	
2	
1	
0	

NOTE:

1. If a lock code has been programmed then the user will be asked for the code upon entering into programming mode. **The factory default lock code is 01000.**

First Menu Level	
1	rAtE-Un
2	rAtE-dP
3	tot-Un

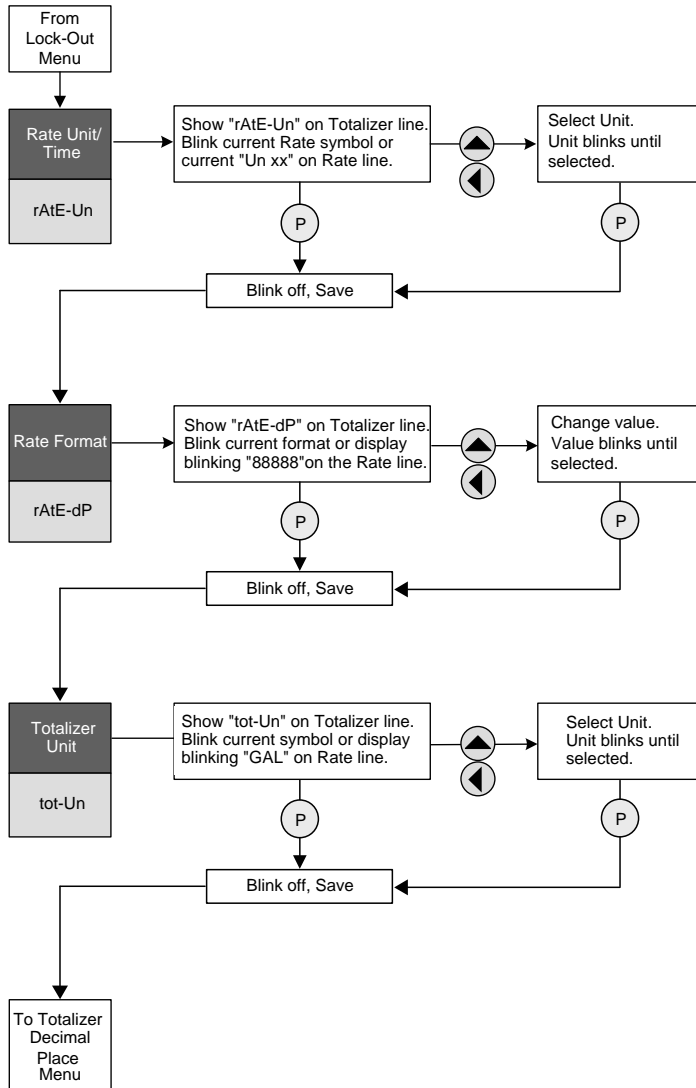

Display	Units of Measure
Un 22	Barrels per day (42G)
Un 21	Barrels per hour (42G)
Un 20	Barrels per minute (42G)
Un 19	Barrels per day (55G)
Un 18	Barrels per hour (55G)
Un 17	Barrels per minute (55G)
Un 16	Cubic feet per minute
Un 15	Cubic meters per minute
Un 14	Liters per hour
Un 13	Kiloliters per hour
Un 12	Acre-feet per day
Un 11	Miner's inch (11.22G)
Un 10	Miner's inch (9G)
Un 9	Imperial gallons per minute
Un 8	Gallons per hour
Un 7	Liters per minute
CMH	
LPS	
MLD	
CFS	
MGD	
GPM	

Sets both Rate Unit and period. Default is the "GPM" symbol. Cycles the Unit selection from the current (or default) selection through the set of symbols and text selections.

Display	Units of Measure
88800	Set rate display format. Default is "88888"
88880	
88888	
8888.8	
8888.88	
88.888	
8.8888	

Cycles the format from the current selection.

Display	Units of Measure
Un 54	Miner's inch-hour (9G)
Un 53	Miner's inch-day (9G)
Un 52	Miner's inch-hour (11.22G)
Un 51	Miner's inch day (11.22G)
Un 50	Miner's inch (9G)
Un 49	Miner's inch (11.22G)
Un 48	Ton (Short)
Un 47	Acre-inch
Un 46	Imperial gallon
Un 45	Barrel (55G)
Un 44	Barrel (46G)
Un 43	Barrel (42G)
Un 42	Barrel (31G)
Un 41	Metric ton (KL)
Un 40	Megaliter
AFT	
CUM	
LIT	
CUF	
GAL	

Applies factor to convert gallons to customer's unit. Cycles the Unit from the current selection through the set of symbols and text selections. Default is the "GAL" symbol.

NOTES:

1. "Un XX" are units of measures that do not have an abbreviated symbol directly on the display.
2. The rate unit selection for the flow rate and 4-20mA full scale is chosen from the same menu table.
3. The total unit selection for the total and pulse output increment is chosen from the same menu table.

First Menu Level	
4	tot-dP-E
5	tot-dP
	Tot-FAct
6	20mA-Un

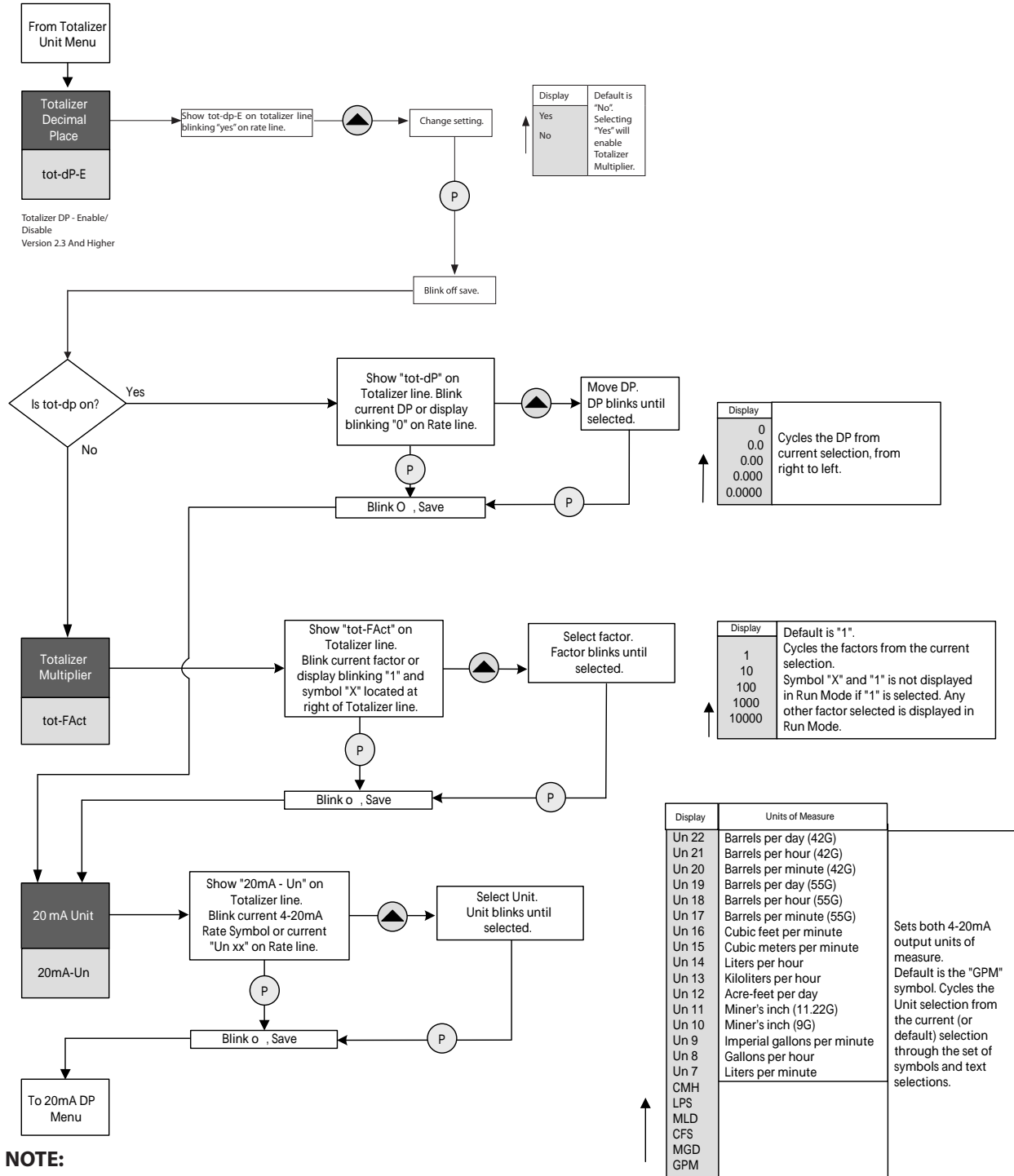

NOTE:

1. The cumulative total can either have a decimal point or a multiplier setting but not both simultaneously.

First Menu Level	
7	20mA-dP
8	20mA-FS
9	PLS-Un

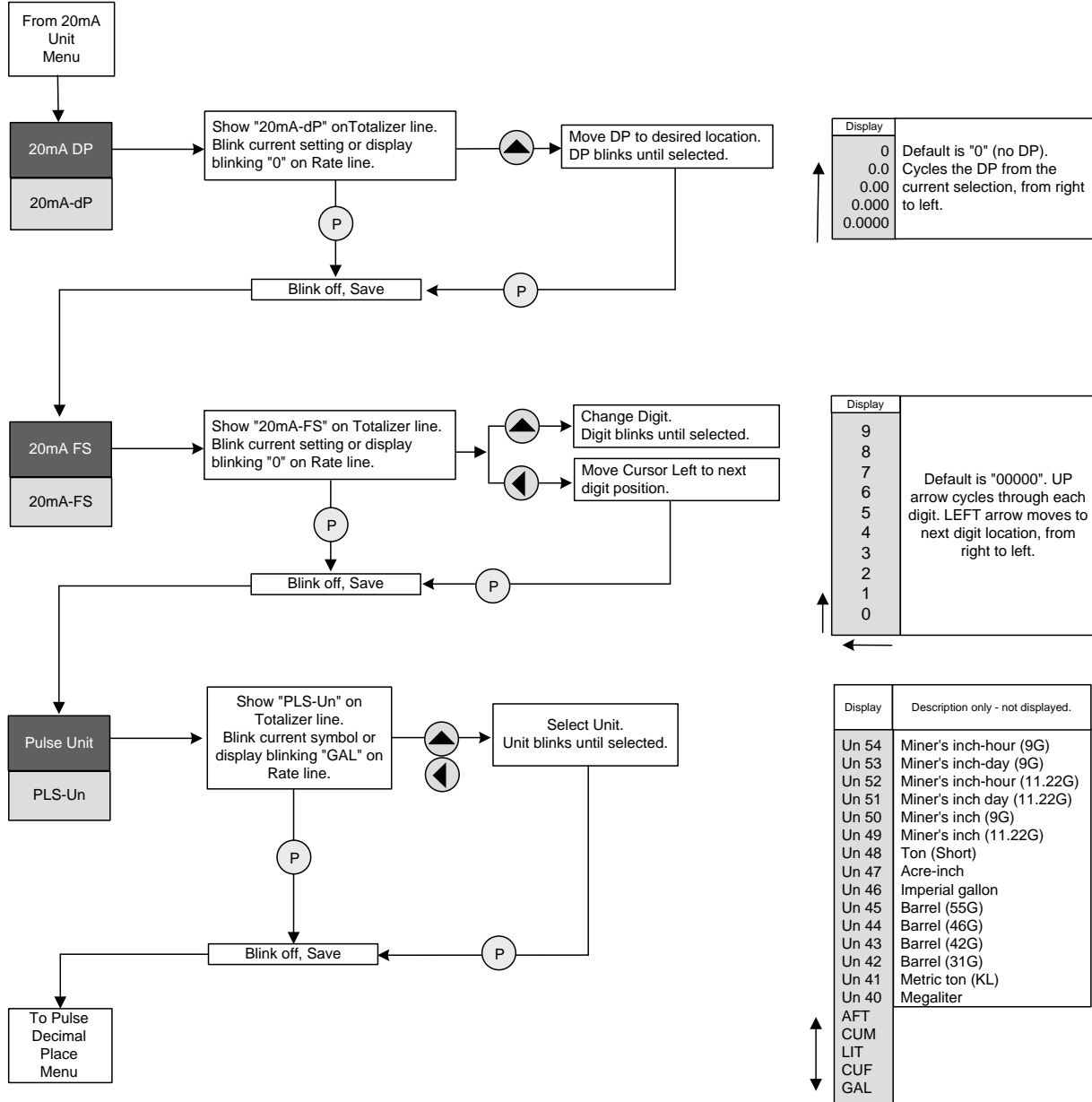

First Menu Level	
10	PLS-dP
11	PLS-Inc
12	CAL-Pct
13	-Go to

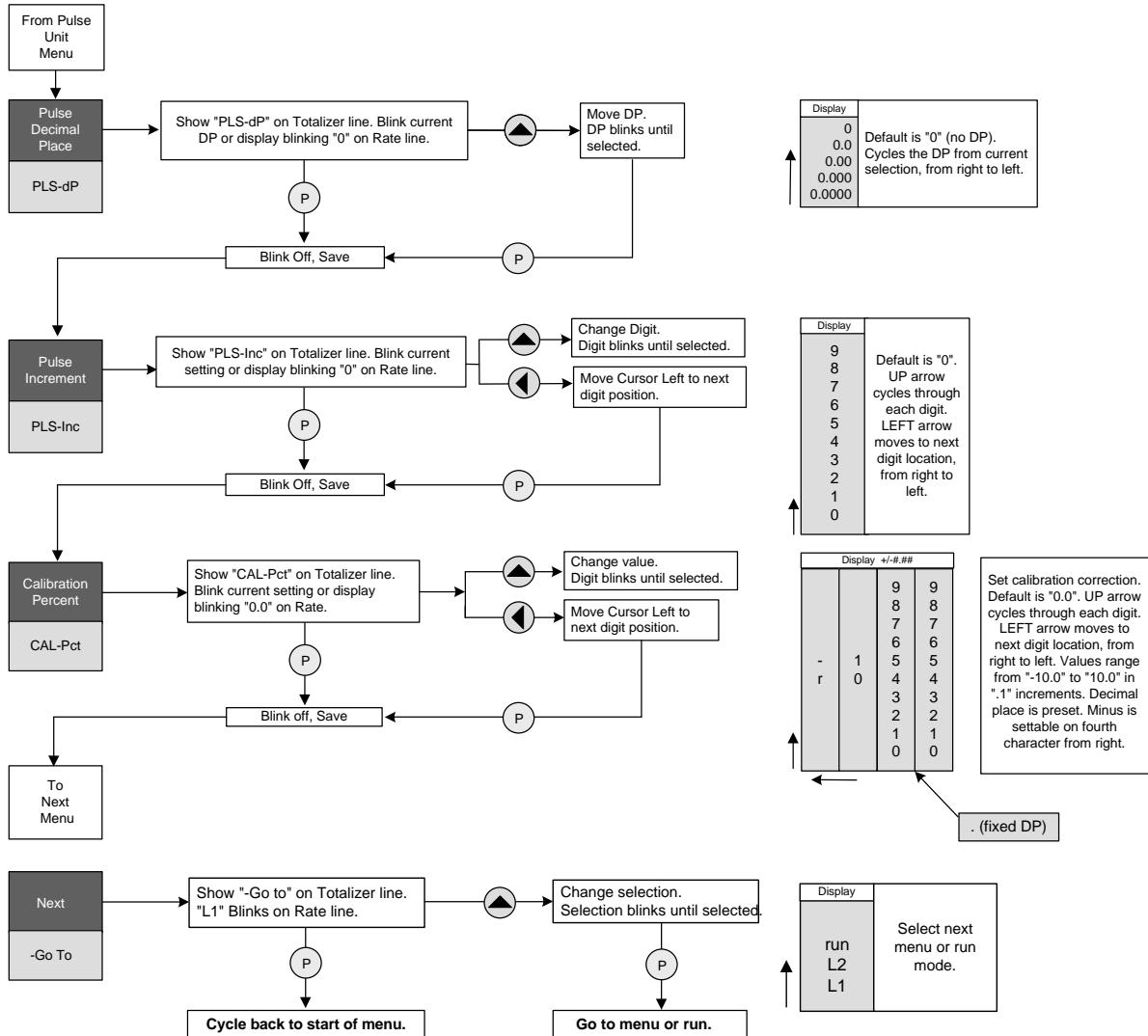

NOTES:

1. Pulse increment is used to set the amount of volume that initiates one pulse output. For example, as the pulse unit of measure is set to "Gallon" and the Pulse Increment is set to "1000", then one pulse will be generated for every 1000 gallons of fluid flowing through the system.
2. The type of pulse output is set by the pulse type in menu L2. The type of pulse output is set by the pulse type in menu L2.

Second Menu Level	
1	Par-S
2	SErno

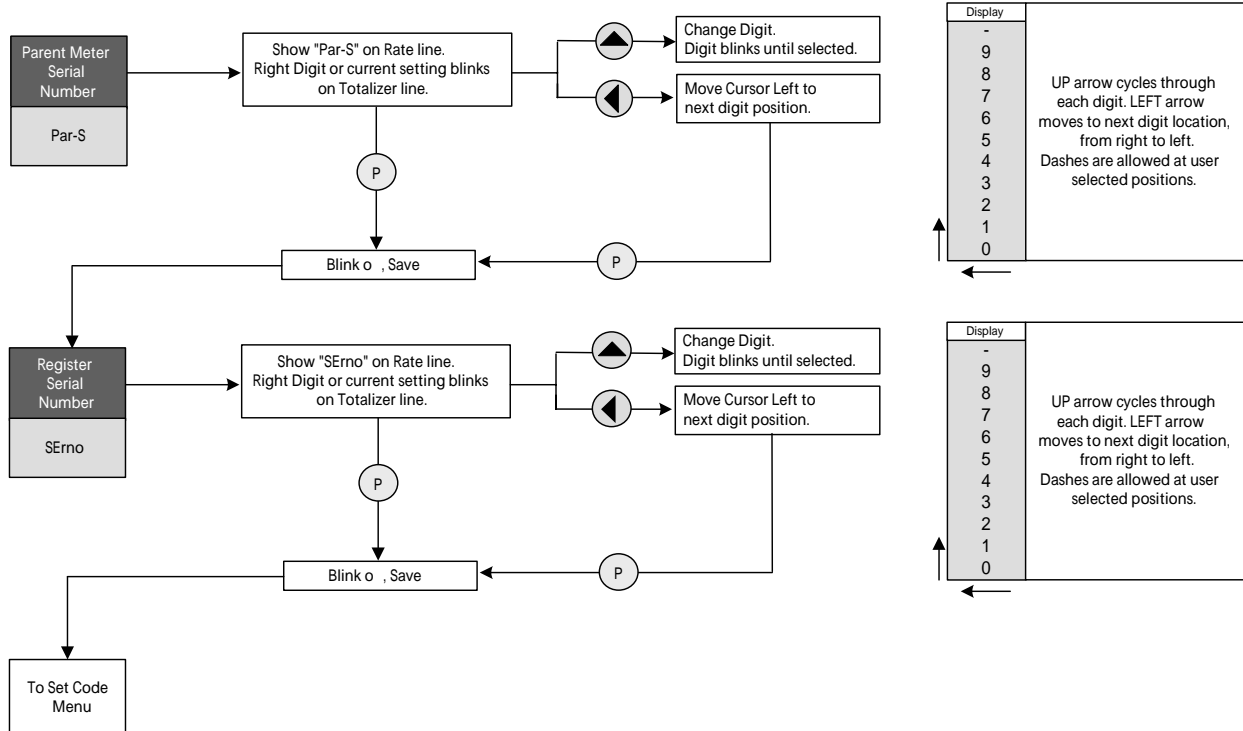

NOTE:

1. Each electronic register has a unique serial number separate from the meter (parent) serial number.

Second Menu Level	
3	Set-CodE
4	GPr-dP
5	GPr
6	Smooth

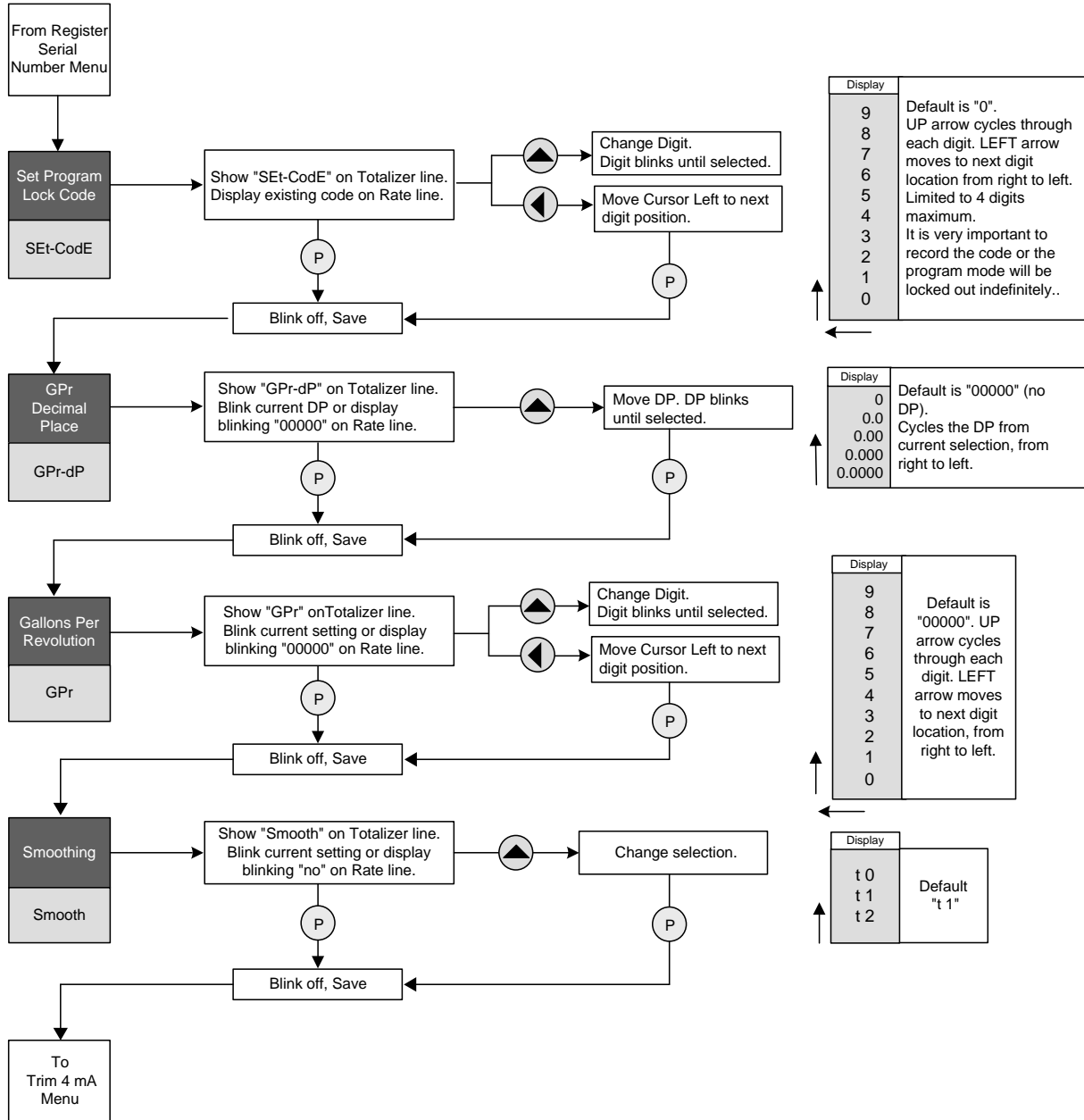

Second Menu Level	
7	4mA-AdJ
8	20mA-AdJ
9	PLS-tYPE
10	PLSwidth **

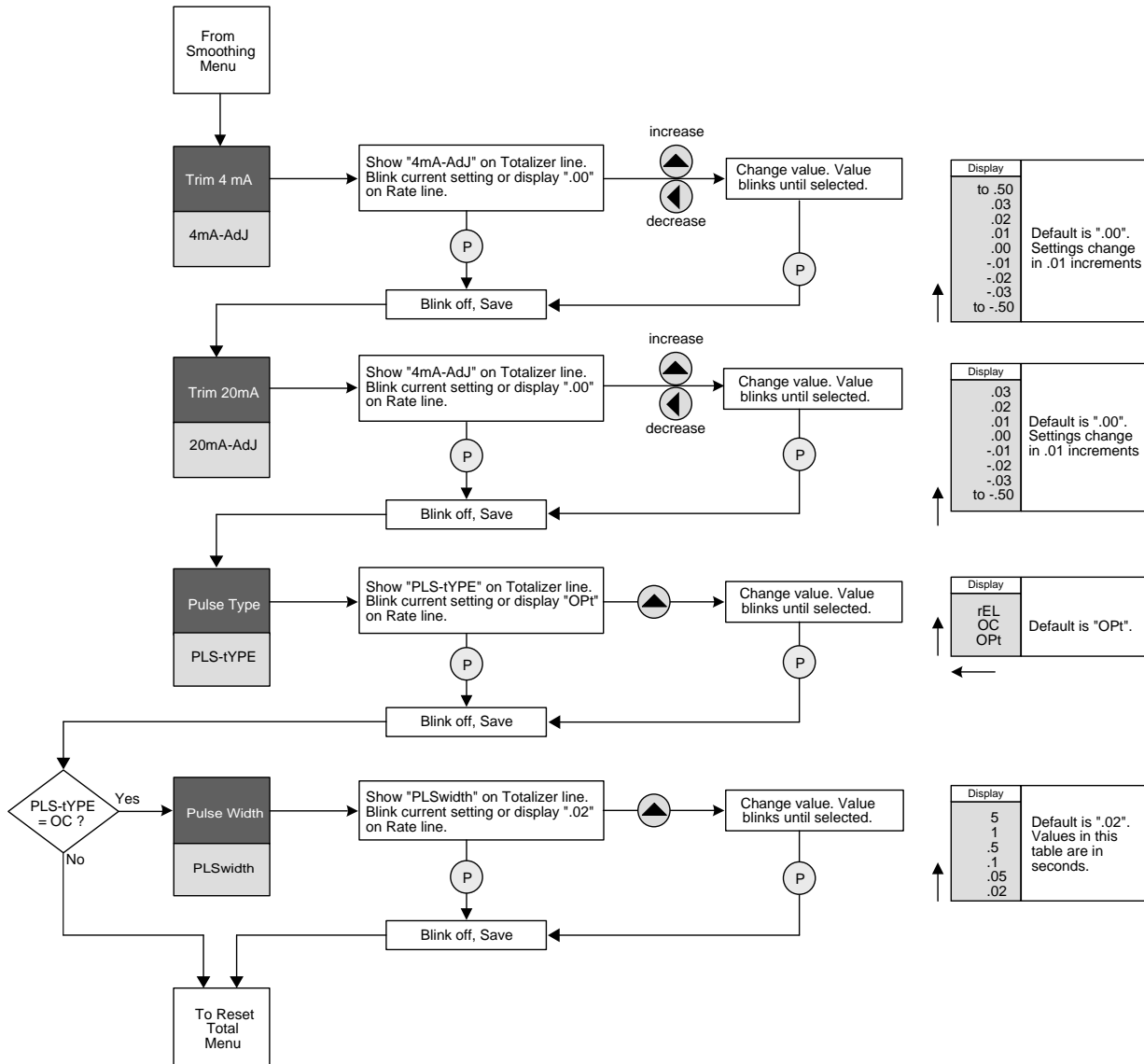

NOTES:

1. The pulse width setting is only available for a standard open collector output.
2. 4-20mA can be calibrated by adjusting the 4mA and 20mA trim values.

Second Menu Level	
11	RESEttot
12	DIS-rSt
13	tot-S
14	Au-InP

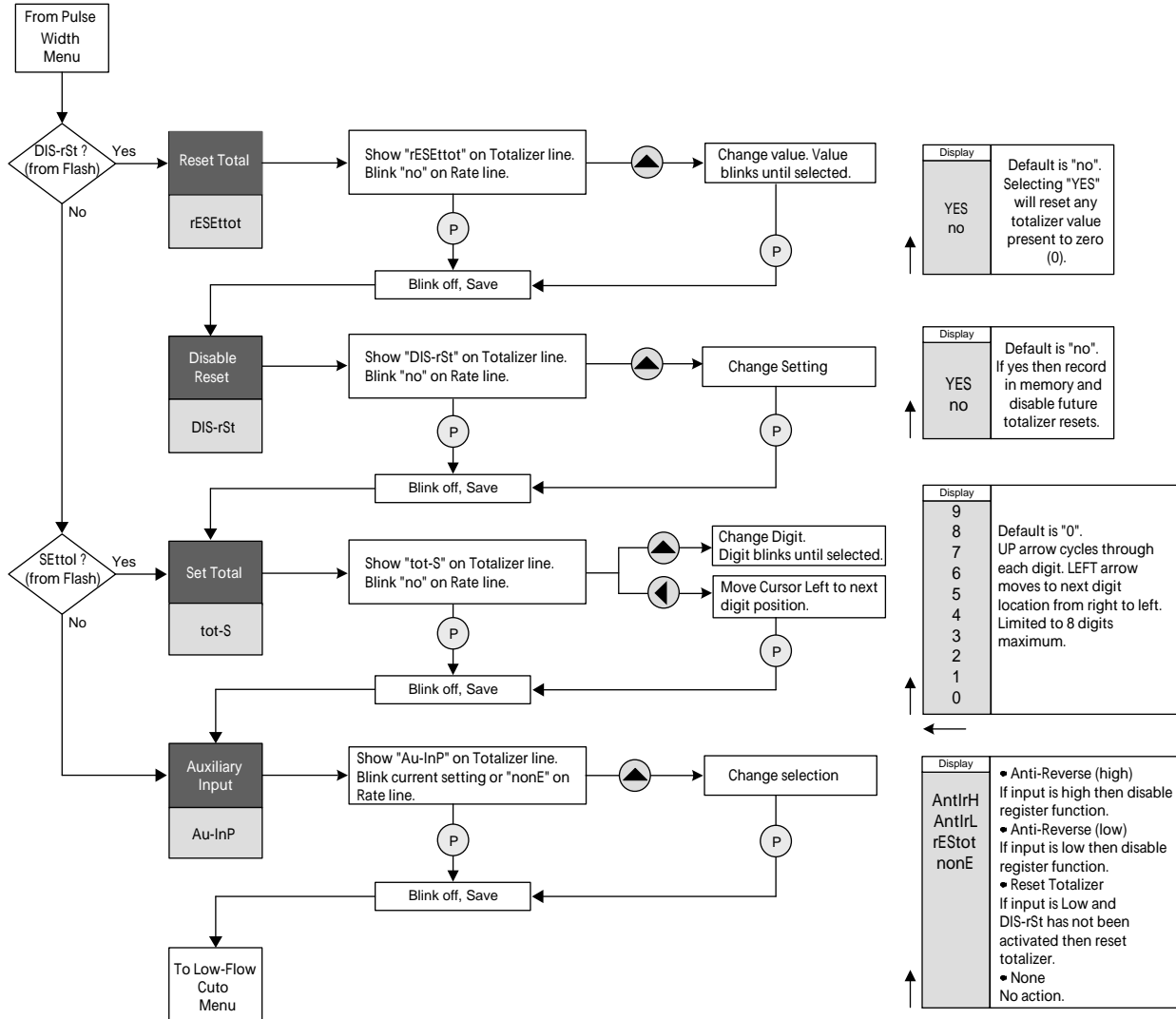

NOTES:

1. The ability to reset the cumulative total can be *permanently* disabled. Once the reset is disabled, the Reset Total function will no longer appear in the menu.
2. The Auxiliary Input function is available for usage to stop the register from totalizing and transmitting. The factory should be consulted if this feature is required.

Second Menu Level	
15	cutoff
16	PLS-Pr
17	-Go to

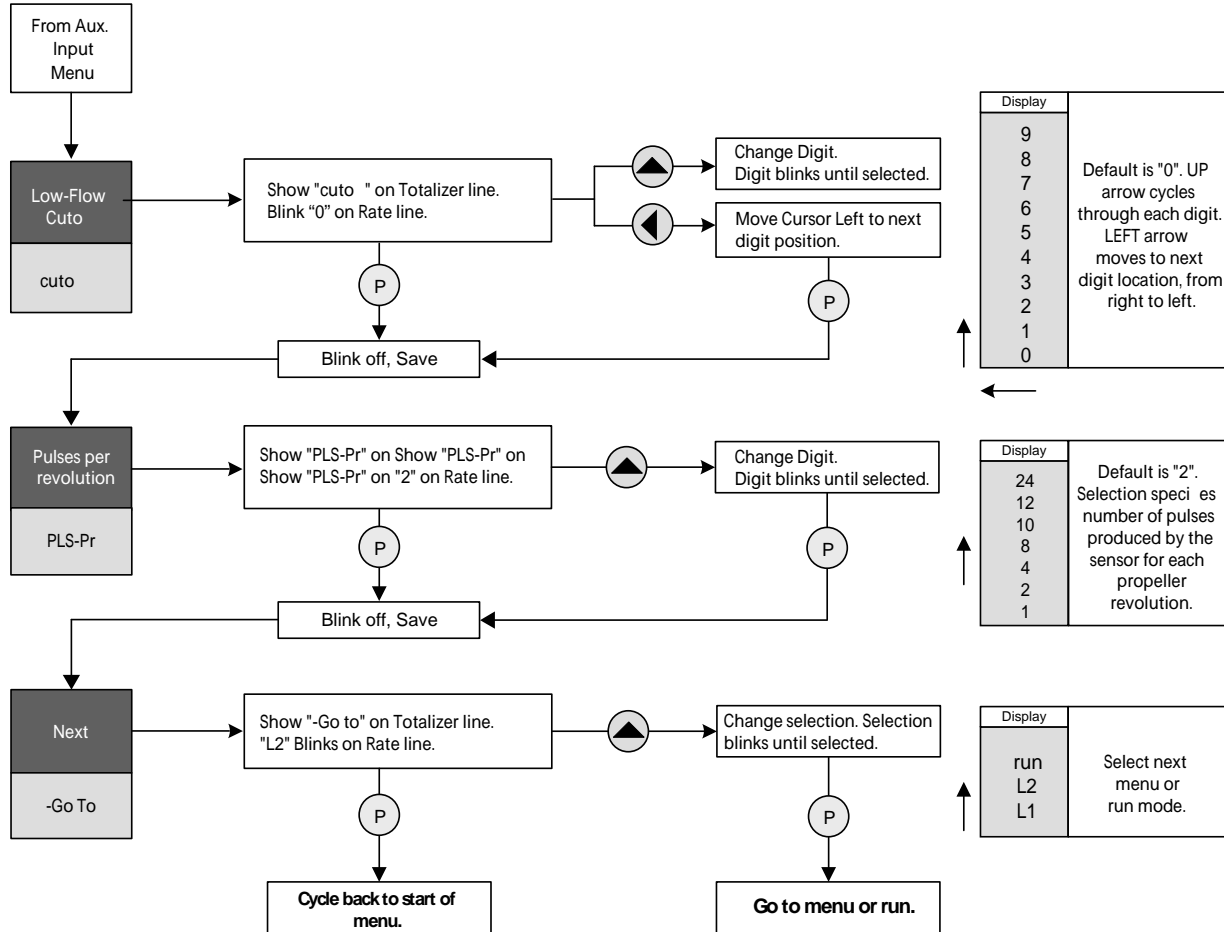

NOTE:

1. Entering the correct pulses per revolution is very important. Contact the factory regarding the pulses per revolution if unknown.

4.5 Configuration Examples

Example 1: Register With DC-powered Optically-Isolated O.C. Pulse Output

Meter Size : 6"
 Gallons Per Revolution: 1.4815
 Rate Units: Cubic Feet per Second
 Totalizer Units: Acre Feet x 0.001
 4-20mA Full Scale: 2.5 CFS
 Switch Closure Output: 1 Switch for Every 1000 Gallons
 Sensor Type: 2 PPR

Configuration Settings:

Menu Item Display	Menu Item Description	Item Selection
rAtE-Un	Rate Unit	CFS
rAtE-dP	Rate Format	888.88
tot-Un	Totalizer Unit	AFT
tot-dP-E	Totalizer Decimal Point Enable	On
tot-dP	Totalizer Decimal Place	0.000
Tot-FAct	Totalizer Multiplier	(Not applicable with a tot-dP setting)
20mA-Un	20 mA Unit	CFS
20mA-dP	20 mA dp	0.0
20mA-FS	20 mA FS	2.5
PLS-Un	Pulse Units	GAL
PLS-dP	Pulse Decimal Place	0
PLS-Inc	Pulse Increment	1000
SErno	Reg. Serial Number	(Serial number is set at the factory)
GPr-dP	GPR Decimal Place	0.0000
GPr	Gallons Per Rev	1.4815
Smooth	Smoothing	t1
4mA-AdJ	Trim 4mA	.00 (Adjusted during 4-20mA calibration)
20mA-AdJ	Trim 20mA	.00 (Adjusted during 4-20mA calibration)
PLS-tYPE	Pulse Type	rEL
PLSwidth	Pulse Width	(Not applicable for the dry contact switch output)
Au-InP	Auxiliary Input	nonE
Cut-dP	Low-Flow Cutoff DP	0
cutoff	Low-Flow Cutoff	0
PLS-Pr	Pulse Per Rev	2

NOTE:

1. The dry contact switch pulse output commonly used on Scada and irrigation systems. The dry contact switch pulse length is not adjustable.

Example 2: Register With Battery-Powered O.C. Pulse Output

Meter Size : 24"
 Gallons Per Revolution: 37.0
 Rate Units: MGD
 Totalizer Units: Gallons x 10000
 Open Collector Pulse Output: 1 Pulse for Every 0.01 Acre Foot
 Pulse Width: 0.1 milliseconds
 Sensor Type: 2 PPR

Configuration Settings:

Menu Item Display	Menu Item Description	Item Selection
rAtE-Un	Rate Unit	MGD
rAtE-dP	Rate Format	8888.8
tot-Un	Totalizer Unit	GAL
tot-dP-E	Totalizer Decimal Point Enable	Off
tot-dP	Totalizer Decimal Place	(Not applicable with a tot-Fact setting)
Tot-FACT	Totalizer Multiplier	X 10000
20mA-Un	20 mA Unit	GAL
20mA-dP	20 mA dp	0
20mA-FS	20 mA FS	0 (4-20mA full scale not defined)
PLS-Un	Pulse Units	AFT
PLS-dP	Pulse Decimal Place	0.00
PLS-Inc	Pulse Increment	0.01
Par-S	Parent Serial Number	(Serial number is set at the factory)
SErno	Reg. Serial Number	(Serial number is set at the factory)
GPr-dP	GPR Decimal Place	00000
GPr	Gallons Per Rev	37
Smooth	Smoothing	t1
4mA-AdJ	Trim 4mA	.00 (Adjusted during 4-20mA calibration)
20mA-AdJ	Trim 20mA	.00 (Adjusted during 4-20mA calibration)
PLS-tYPE	Pulse Type	OC
PLSwidth	Pulse Width	0.1
Au-InP	Auxiliary Input	nonE
Cut-dP	Low-Flow Cutoff DP	0
cutoff	Low-Flow Cutoff	0
PLS-Pr	Pulse Per Rev	2

NOTE:

1. Optically-isolated open collector and dry contact switch closure outputs are not applicable because they both require DC power. The pulse width length is an option only for the standard open collector pulse output.

Example 3: Register With 4-20mA Transmitter Output

Meter Size : 4"
 Gallons Per Revolution: 0.5
 Rate Units: Liters Per Hour
 Totalizer Units: Metric Ton x 1
 4-20mA FS: 100 LPM
 Sensor type: 2 PPR

Configuration Settings:

Menu Item Display	Menu Item Description	Item Selection
rAtE-Un	Rate Unit	Un 14 (No symbol on display)
rAtE-dP	Rate Format	88888
tot-Un	Totalizer Unit	Un 7 (No symbol on display)
tot-dP-E	Totalizer Decimal Point Enable	Off
tot-dP	Totalizer Decimal Place	0
Tot-FAct	Totalizer Multiplier	X 1
20mA-Un	20 mA Unit	Un 7 (Un 7 is an reference to a rate unit)
20mA-dP	20 mA dp	0
20mA-FS	20 mA FS	100
PLS-Un	Pulse Units	GAL
PLS-dP	Pulse Decimal Place	0
PLS-Inc	Pulse Increment	0 (No pulse output defined)
Par-S	Parent Serial Number	(Serial number is set at the factory)
SErno	Reg. Serial Number	(Serial number is set at the factory)
GPr-dP	GPR Decimal Place	0000.0
GPr	Gallons Per Rev	0.5
Smooth	Smoothing	t1
4mA-AdJ	Trim 4mA	.00 (Adjusted during 4-20mA calibration)
20mA-AdJ	Trim 20mA	.00 (Adjusted during 4-20mA calibration)
PLS-tYPE	Pulse Type	Opt (Type is irrelevant since there the pulse increment is not defined)
PLSwidth	Pulse Width	(Not applicable for the optically-isolate open collector pulse output)
Au-InP	Auxiliary Input	nonE
Cut-dP	Low-Flow Cutoff DP	0
cutoff	Low-Flow Cutoff	0
PLS-Pr	Pulse Per Rev	2

NOTE:

1. In this example, units of measures "Un XX" are used at three different settings. There will not be any unit of measure symbol on the display. The cumulative total is using "Un 7" from the set of total units, and the 4-20mA is using "Un 7" from the set of rate units.

5.0 PRODUCT SPECIFICATIONS

5.1 Features and Specifications

- Retrofits to any existing Mc Propeller or Water Specialties Propeller Flowmeter.
- Four output options: 4-20mA Loop, Open Collector, Optically Isolated, and Contact Closure.
- Unique Units of Measurement for Rate, Total, 4-20mA and Pulse Outputs.
- Factory sealed Remote and Meter-Mounted Models.
- Sensus compatible with three wire protocol

<p>Environmental</p> <p>Operating Temp.: -4°F to 158°F (-20°C to 70°C)</p> <p>Storage Temperature: -40°F to 158°F (-40°C to 70°C)</p> <p>Housing Rating: NEMA 4X</p> <p>Meter Rating (with Remote Mount): IP67</p>	<p>4-20mA Analog</p> <p>Power Requirements: 12 to 30 VDC</p> <p>Transmission: 5,000 feet max.</p> <p>4mA/20mA Trim: .01 mA to .50 mA</p> <p>Engineering/Time Units: 22 different units</p>
<p>Input Signal</p> <p>Input Compatibility: McCrometer Flow Meters</p> <p>Remote Distance: 50 feet max.</p>	<p>Pulse Outputs</p> <p>Engineering Units: 20 different units</p>
<p>Rate Functions</p> <p>Display: 5-digit</p> <p>Rate Units: 22 different units</p> <p>Totalizer Functions</p> <p>Display: 8-Digit</p> <p>Totalizer Units: 20 different units</p> <p>Accuracy: 0.25%</p> <p>Non-Volatile Storage: Updated hourly</p> <p>Scaling Factor: .0001 to 10000</p>	<p>Optically Isolated Pulse</p> <p>Collector to emitter voltage: 50V @ 50 mA max.</p> <p>Pulse Width: 80 ms</p> <p>Max Pulses Per Minute: 30</p> <p>Signal Distance: 500 feet max.</p> <p>Open Collector Pulse</p> <p>Collector to emitter voltage: 50V @ 50 mA max.</p> <p>Pulse Width: adjustable</p> <p>Max Pulses Per Minute: 30</p> <p>Signal Distance: 500 feet max.</p>
<p>Programming</p> <p>Program Access: Magnetic wand (included)</p> <p>Programming: Menu driven</p> <p>Access Lockout: 5-digit code</p> <p>Test Modes: 4 mA and 20 mA test modes</p> <p>Totalizer Reset: Programming</p> <p>Total Reset Disable: Programming (permanent)</p> <p>Calibration Adjustment: ± .01% to 10%</p>	<p>Contact Closure</p> <p>Contact Rating: 30V @ 1 Amp Max.</p> <p>Pulse Width: 80 ms</p> <p>Max Counts Per Minute: 150</p> <p>Signal Distance: 500 feet</p> <p>Power Requirement</p> <p>Battery Type: Lithium 3.6 V</p> <p>Battery Life: 6 - 10 Years</p> <p>Optional 4-20mA: Loop powered</p>

5.2 Dimensions

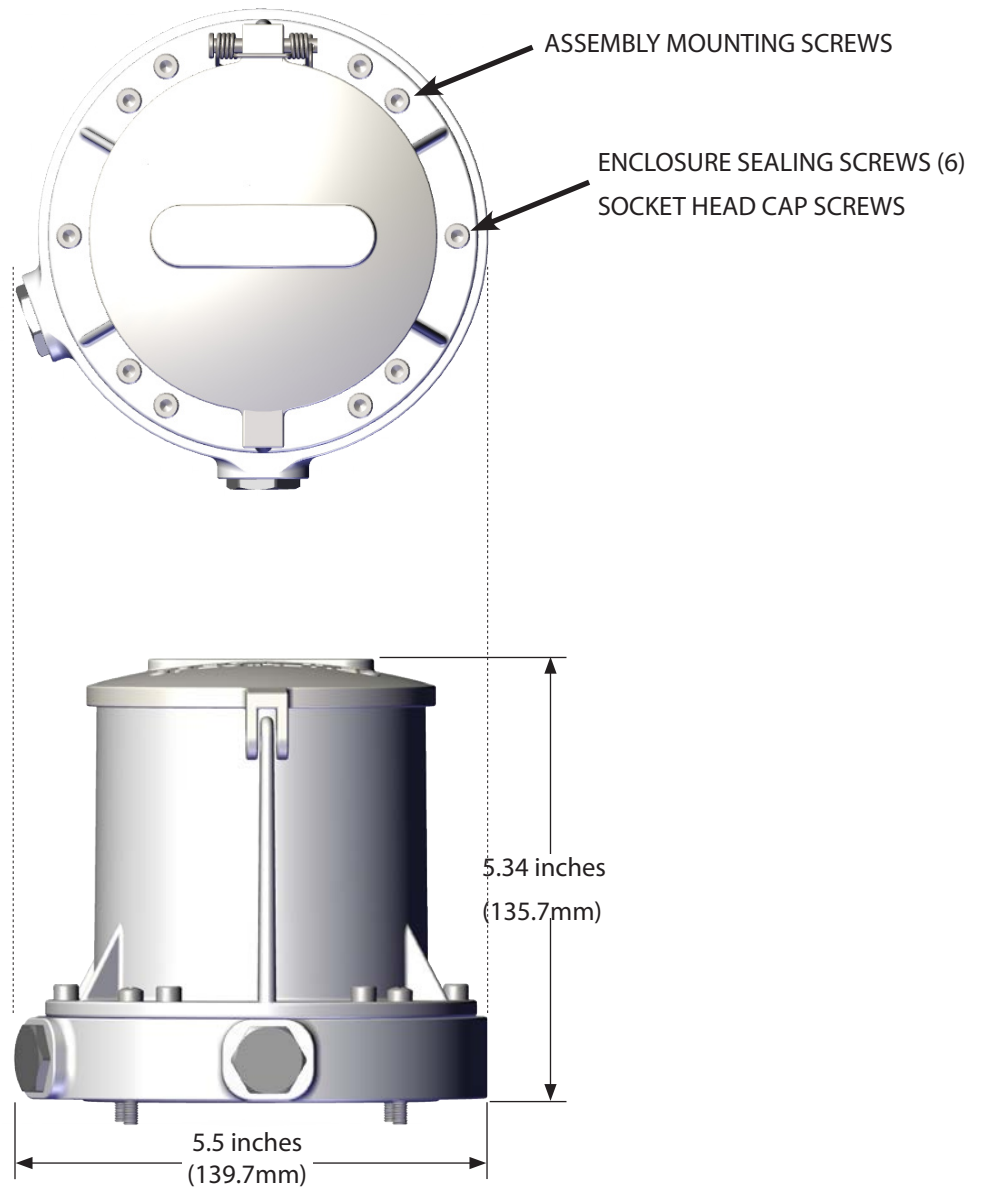

Figure 18. FlowCom Housing

5.3 Housing

The enclosure assembly is sealed by six socket head cap screws. The enclosure cover and base are made of aluminum and coated for all weather use.

PRODUCT SPECIFICATIONS

5.4 Parts List

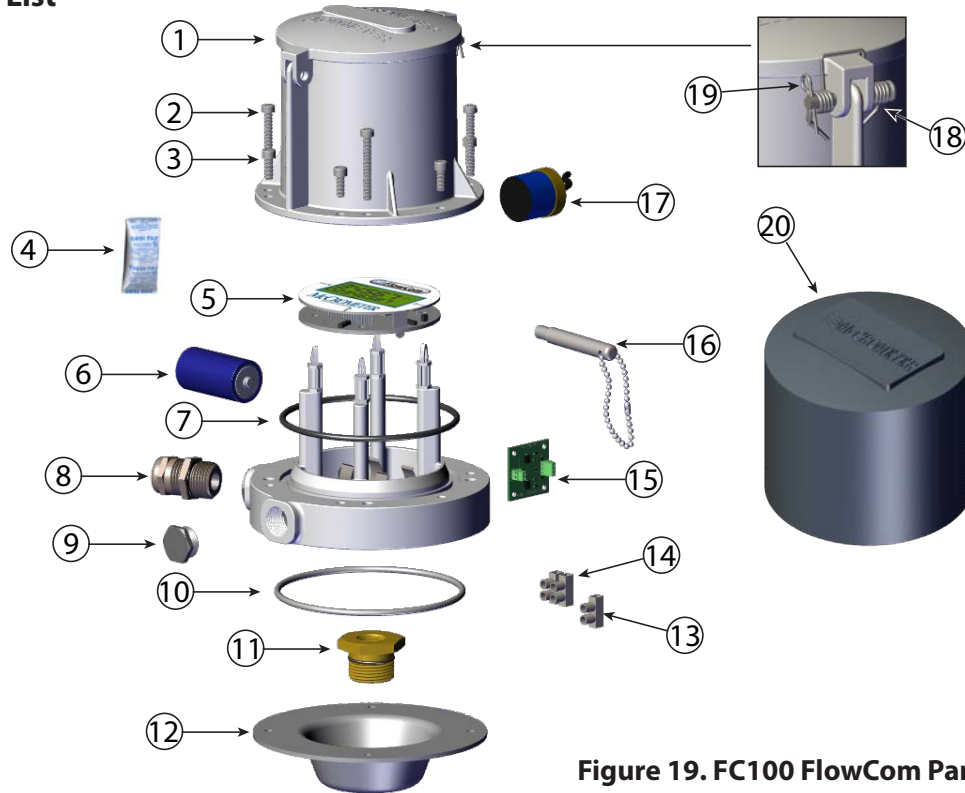

Figure 19. FC100 FlowCom Parts

Ref.	Part Number	Description	Qty
1	R0710-40	Canopy Enclosure McCrometer	1
2	10605	Screw 10-32 x 1.25" Long	4
3	10602	Screw 10-32 x 0.5" Long Socket Head Cap	6
4	10015-00	Dry Pack	2
5	ELR500-01	Electronic Register	1
6	EZ100-00	Battery C 3.6V Lithium	1
7	10285	O-Ring (241 Buna)	1
8	EJ539-00 / EJ543-00	Fitting Cable Compression PG7 (Inside) / Fitting Cable PG11 Brass Plate (Outside)	Note 1
9	EJ544-00-K	Plug Cable PG11 Hex Head Brass Plate w/O-ring	Note 1
10	1-1551-38	O-Ring (243 Buna)	1
11	R0147-00	Hex Bushing with O-rings (021 Buna and 121 Buna)	1
12	R0138-10	Mounting Plate	1
13	1-1707-18	Inline Terminal 1 Wire	1
14	1-1707-19	Inline Terminal 2 Wire	1
15	EB420-01	4-20mA Protection Board	1
16	FC100-M	Magnet Wand	Note 2
17	EA530-00 / EA538-00	Pulse Transmitter 2 PPR or Pulse Transmitter 8 PPR (36" and larger)	1
18	SP100-00	Spring Double Torsion F/Canopy	1
19	RP100-00	Retaining Pin SS F/Canopy	1
20	CB100-10	Canopy Boot	1

NOTES:

- Quantity is based on the model selected.
- The FC100-M quantity varies depending on quantity of FC100-XX registers on the sales order (2 per sales order line item).

Recommended parts for technicians: FC100-M (2 each), EZ100-00 (quantity as required), 10015-00 (quantity as required).

6.0 PRODUCT MAINTENANCE

6.1 Battery Replacement

To replace the battery the canopy enclosure must be removed. The time period which the enclosure is opened should be minimized to reduce moisture and contamination. The battery holder may have a zip tie or other locking mechanism in place which can be removed.

1. Make a note of the enclosure to base orientation prior to disassembly.
2. Remove the enclosure retaining screws and then the cover.
3. Inspect the inside environment of the enclosure and look for damage of any type.
4. Remove the existing battery and discard it following the local government standards.
5. Install the new battery.
6. Verify that the register turns on.
7. Replace the existing dry packs with new dry packs if available.
8. Apply O-ring lube to the cover O-ring (Figure 20).
9. Install the cover and screws.
10. If required re-install tamper evident components.

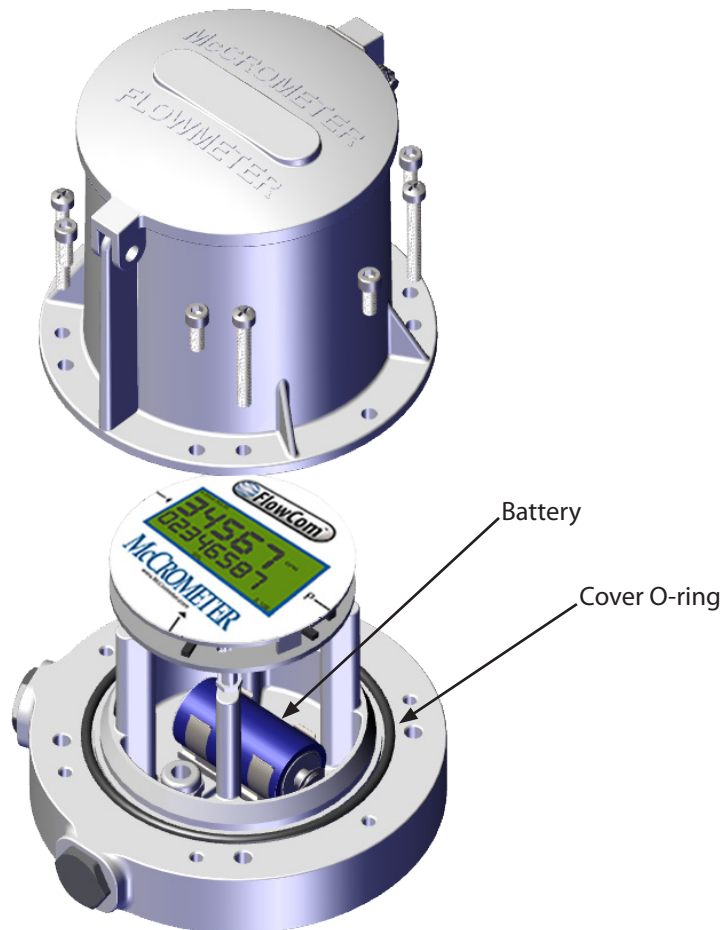

Figure 20. Canopy Enclosure Removed For Battery Replacement

7.0 TROUBLESHOOTING

Inaccurate Rate And Total Readings

- A. Check the gallons per revolution (GPR) and pulses per revolution (PPR) settings. The electronic register could be programmed with incorrect GPR and PPR values.
- B. Check that the input sensor cable's shield wire is connected to the earth ground, per instructions on tag. Also, check the connection of the shield wire on the outside instrumentation side of the output cable, per instructions on tag.
- C. If there is known noisy process instrumentation close to the installation, such as variable frequency drives, use the crimped green wire to connect any of the screws on the FlowCom's canopy to a known good earth ground, such as a copper rod inserted 4' (four feet) into the ground.

No Optically-Isolated Pulse Or Dry Contact Switch Output

- A. Verify that both the 4-20mA loop power and DC power to the optically-isolated pulse/dry contact switch are present and connected to the correct output wires.
- B. Check if the power source has the correct pulse voltage and current.
- C. Make sure the ground wire inside the output cable is grounded on the instrument side.
- D. Check whether a pull-up resistor is required to produce a signal.

No 4-20mA Transmitter Output

- A. Check that the negative side of the 24VDC (-24VDC) loop power supply is not connected to earth ground. To do this, turn off the 24VDC power supply and use a standard ohm meter to verify that the -24VDC connection is not shorted to the earth ground.
- B. Check whether the 4-20mA loop is connected properly and powered.
- C. Verify that the 20mA unit and full scale are set up in the program configurations.

Non-responsive Rate And Total Readings

- A. Check the connection between the sensor cable and the pulse input cable.

Blank LCD Display

- A. Check whether the 4-20mA loop is powered and/or the battery inside the canopy enclosure is installed properly.

7.1 Circuit Board Connections

The circuit board does not have any serviceable components. Each register is shipped with the cables connected to the appropriate input and output connections per the customer requirements. The circuit board layout is contained in this manual as a technical support reference manual as a technical support reference.

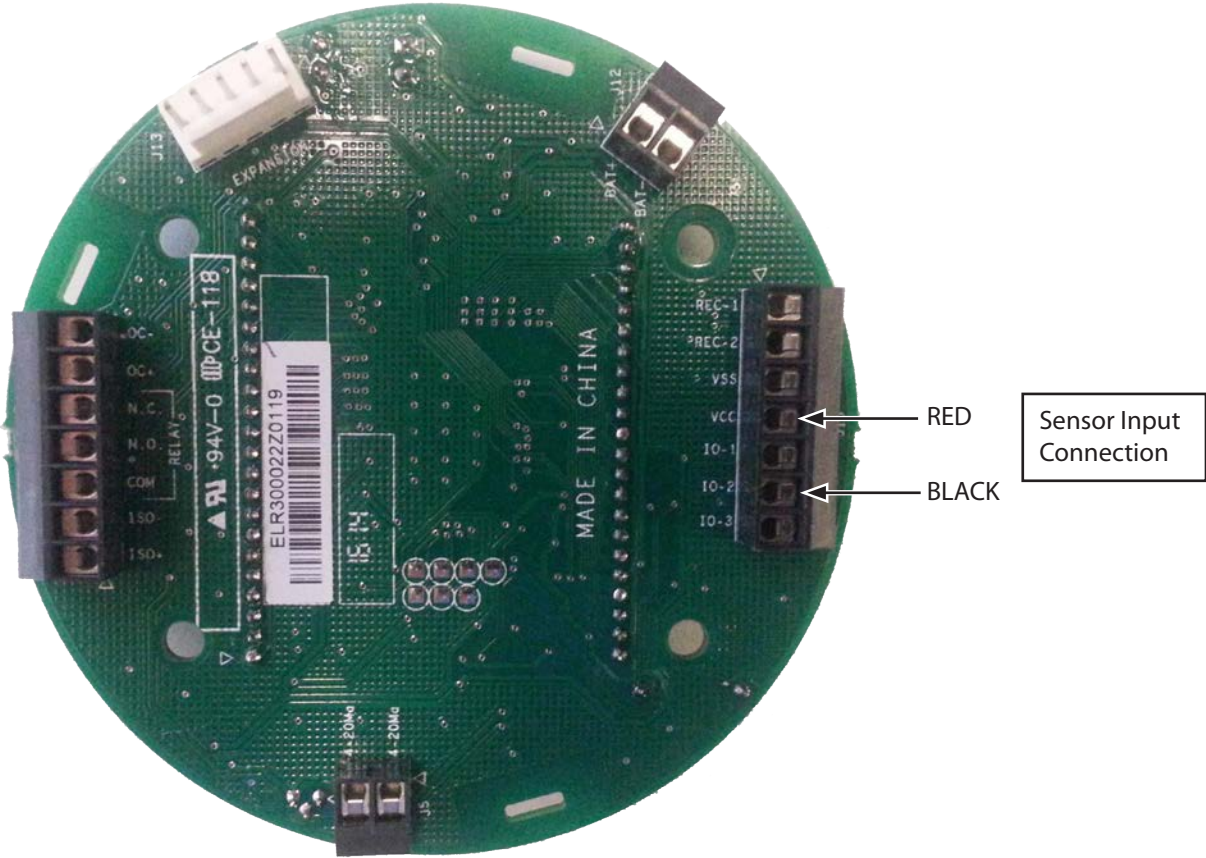

Figure 21. FlowCom Circuit Board

WARRANTY STATEMENT

WARRANTY STATEMENT

Manufacturer warrants all products of its manufacture to be free from defects in workmanship and material under normal use and service. This warranty extends for a period of twelve (12) months after date of shipment, unless altered by mutual agreement between the purchaser and manufacturer prior to the shipment of the product. If this product is believed to be defective, purchaser shall notify manufacturer and will return the product to the manufacturer, postage paid, within twelve (12) months after date of shipment by the manufacturer. If the purchaser believes the return of the product to be impractical, manufacturer shall have the option, but will not be required, to inspect the product wherever located. In any event, if the purchaser requests the manufacturer visit their location, the purchaser agrees to pay the non-warranty expenses of travel, lodging and subsistence for the field service response. If the product is found by the manufacturer's inspection to be defective in workmanship or material, the defective part or parts will either be repaired or replaced, at manufacturer's election, free of charge, and if necessary the product will be returned to purchaser, transportation prepaid to any point in the United States. If inspection by the manufacturer of such product does not disclose any defect of workmanship or material, manufacturer's regular service repair charges will apply. Computing devices sold but not manufactured by McCrometer, Inc. are covered only by the original manufacturer's written warranty. Hence, this warranty statement does not apply.

THE FOREGOING WARRANTY IS MANUFACTURER'S SOLE WARRANTY, AND ALL OTHER WARRANTIES, EXPRESS, IMPLIED OR STATUTORY, INCLUDING ANY IMPLIED WARRANTY OF MERCHANTABILITY OR FITNESS FOR A PARTICULAR PURPOSE, ARE NEGATED AND EXCLUDED. THE FOREGOING WARRANTY IS IN LIEU OF ALL OTHER WARRANTIES, GUARANTEES, REPRESENTATIONS, OBLIGATIONS OR LIABILITIES ON THE PART OF THE MANUFACTURER.

Purchaser's sole remedy and manufacturer's sole obligation for alleged product failure, whether under warranty claim or otherwise, shall be the aforesated obligation of manufacturer to repair or replace products returned within twelve months after date of original shipment. The manufacturer shall not be liable for, and the purchaser assumes and agrees to indemnify and save harmless the manufacturer in respect to, any loss or damage that may arise through the use by the purchaser of any of the manufacturer's products.

If you experience problems with your FlowCom register, please contact your local factory representative for assistance. You may also contact Customer Service at the factory directly at 951-652-6811. Be prepared to provide the serial number off of your meter or FlowCom register (this information is located on the lid of the register).

When returning McCrometer products to the factory for repair or warranty consideration, a return authorization number (RA) must be obtained from the factory and referenced on the outside of the box of the products you are returning. The products should be shipped back to the factory at:

McCrometer
3255 West Stetson Avenue
Hemet CA 92545

OTHER  **McCrometer** PRODUCTS INCLUDE:

 **Propeller Meter**



**Propeller
Flowmeters**



**Differential Pressure
Flowmeters**



**Magnetic
Flowmeters**



**Wireless Monitoring
System**