

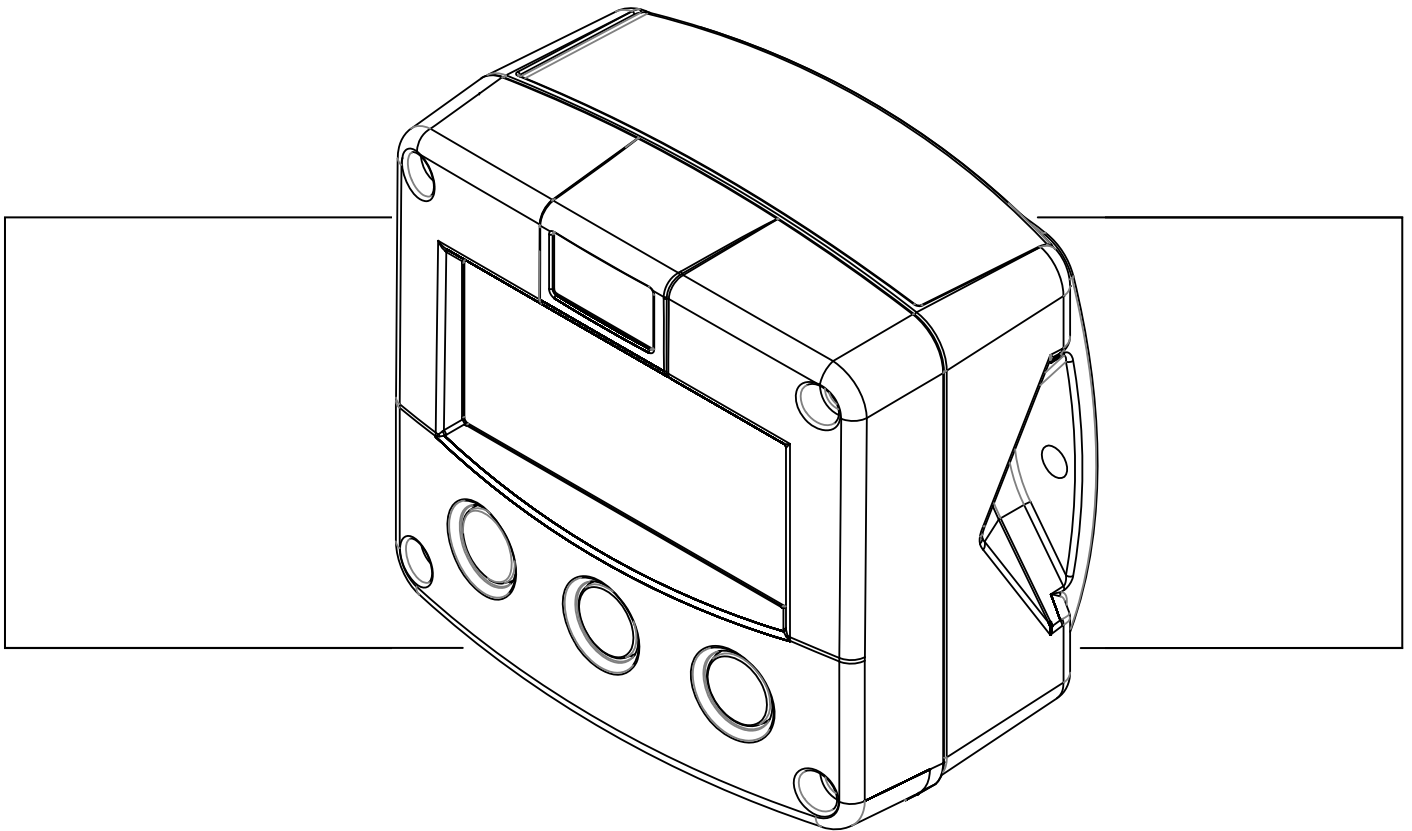

# Flowrate Indicator/Totalizer with Differential and Sum Function

## Owner's Manual – Model F116-P

---



*Signal input flowmeter: pulse, Namur and coil*

*Analog output: 4-20mA ref. flowrate, pulse ref. total and negative flow*

*Options: Intrinsically Safe, Modbus communication and backlight*



## SAFETY INSTRUCTIONS



- *Any responsibility is lapsed if the instructions and procedures as described in this manual are not followed.*
- *LIFE SUPPORT APPLICATIONS: The F116-P is not designed for use in life support appliances, devices, or systems where malfunction of the product can reasonably be expected to result in a personal injury. Customers using or selling these products for use in such applications do so at their own risk and agree to fully indemnify the manufacturer and supplier for any damages resulting from such improper use or sale.*
- *Electro static discharge does inflict irreparable damage to electronics! Before installing or opening the unit, the installer has to discharge himself by touching a well-grounded object.*
- *This unit must be installed in accordance with the EMC guidelines (Electro Magnetic Compatibility).*
- *Do connect a proper grounding to the aluminum casing as indicated if the F116-P has been supplied with the 115-230V AC power-supply type PM. The green / yellow wire between the back-casing and removable terminal-block may never be removed.*
- *Intrinsically Safe applications: follow the instructions as mentioned in Chapter 5 and consult "Fluidwell F1...-XI - Documentation for Intrinsic Safety".*

## DISPOSAL



At the end of its life this product should be disposed of according to local regulations regarding waste electronic equipment. If a battery is present in this product it should be disposed of separately. The separate collection and recycling of your waste equipment will help to conserve natural resources and ensure that it is recycled in a manner that protects the environment.

## SAFETY RULES AND PRECAUTIONARY MEASURES

- The manufacturer accepts no responsibility whatsoever if the following safety rules and precautions instructions and the procedures as described in this manual are not followed.
- Modifications of the F116-P implemented without preceding written consent from the manufacturer, will result in the immediate termination of product liability and warranty period.
- Installation, use, maintenance and servicing of this equipment must be carried out by authorized technicians.
- Check the mains voltage and information on the manufacturer's plate before installing the unit.
- Check all connections, settings and technical specifications of the various peripheral devices with the F116-P supplied.
- Open the casing only if all leads are free of potential.
- Never touch the electronic components (ESD sensitivity).
- Never expose the system to heavier conditions than allowed according to the casing classification (see manufacture's plate and chapter 4.2.).
- If the operator detects errors or dangers, or disagrees with the safety precautions taken, then inform the owner or principal responsible.
- The local labor and safety laws and regulations must be adhered to.

## ABOUT THE OPERATION MANUAL

This operation manual is divided into two main sections:

- The daily use of the unit is described in chapter 2 "Operation". These instructions are meant for users.
- The following chapters and appendices are exclusively meant for electricians/technicians. These provide a detailed description of all software settings and hardware installation guidance.

This operation manual describes the standard unit as well as most of the options available. For additional information, please contact your supplier.

**A hazardous situation may occur if the F116-P is not used for the purpose it was designed for or is used incorrectly. Please carefully note the information in this operating manual indicated by the pictograms:**



A "**warning**" indicates actions or procedures which, if not performed correctly, may lead to personal injury, a safety hazard or damage of the F116-P or connected instruments.



Caution !

A "**caution**" indicates actions or procedures which, if not performed correctly, may lead to personal injury or incorrect functioning of the F116-P or connected instruments.



Note !

A "**note**" indicates actions or procedures which, if not performed correctly, may indirectly affect operation or may lead to an instrument response which is not planned.

Hardware version	:	02.01.xx
Software version	:	02.05.xx
Manual	:	GPI_F116PEN_v0501_04
© Copyright 2015	:	Fluidwell bv - The Netherlands.

**Information in this manual is subject to change without prior notice. The manufacturer is not responsible for mistakes in this material or for incidental damage caused as a direct or indirect result of the delivery, performance or use of this material.**

**© All rights reserved. No parts of this publication may be reproduced or used in any form or by any means without written permission of your supplier.**

# CONTENTS MANUAL

Safety instructions .....	2
Safety rules and precautionary measures .....	2
Contents manual.....	4
1. Introduction .....	5
1.1. System description of the F116-P.....	5
2. Operational .....	7
2.1. General .....	7
2.2. Control panel.....	7
2.3. Operator information and functions .....	8
3. Configuration.....	9
3.1. Introduction .....	9
3.2. Programming SETUP-level.....	9
3.2.1. General .....	9
3.2.2. Overview functions SETUP level .....	12
3.2.3. Explanation OF SETUP-functions.....	13
1 - Total A .....	13
2 - Flowrate A.....	14
3 - Total B .....	15
4 - Flowrate B.....	15
5 - Display .....	16
6 - Power management .....	17
7 - Flowmeter .....	18
8 - Analog output.....	19
9 - Relay output.....	20
A - Communication (optional) .....	21
B - Others.....	21
4. Installation.....	22
4.1. General directions .....	22
4.2. Installation / surrounding conditions .....	22
4.3. Dimensions- Enclosure .....	23
4.4. Installing the hardware.....	25
4.4.1. Introduction .....	25
4.4.2. Voltage selection sensor supply .....	26
4.4.3. Terminal connectors .....	27
5. Intrinsically safe applications .....	35
5.1. General information and instructions .....	35
5.2. Terminal connectors Intrinsically Safe applications .....	36
5.3. Configuration Examples.....	38
5.4. Battery replacement instructions.....	40
6. Maintenance .....	41
6.1. General directions.....	41
6.2. Repair.....	41
Appendix A: Technical specification.....	42
Appendix B: Problem solving.....	46
Appendix C: Communication variables.....	47
Index of this manual.....	51
List of figures in this manual .....	52
Declaration of Conformity .....	54

# 1. INTRODUCTION

## 1.1. SYSTEM DESCRIPTION OF THE F116-P

### Functions and features

The flowrate / totalizer model F116-P is a microprocessor driven instrument designed to display flowrate, total and accumulated total based on the calculated differential or count up value of two separated flows.

This product has been designed with a focus on:

- ultra-low power consumption to allow long-life battery powered applications (type PB / PC),
- intrinsic safety for use in hazardous applications (type XI),
- several mounting possibilities with aluminum or GRP enclosures for harsh industrial surroundings,
- ability to process all types of flowmeter signals,
- transmitting possibilities with analog / pulse and communication (option) outputs.

### Flowmeter input

This manual describes the unit with a pulse type input from the flowmeter "-P version". Other versions are available to process (0)4-20mA or 0-10V flowmeter signals.

One flowmeter with a passive or active pulse, Namur or sine wave (coil) signal output can be connected to the F116-P. To power the sensor, several options are available.

### Standard outputs

- Configurable pulse output: a scaled pulse mirroring a certain totalized quantity. Maximum frequency 60Hz.; the pulse length can be set from 7,8msec up to 2 seconds.
- Flow direction output: related to the acc. total it will be switched when counting down.
- Configurable linear (0)4-20mA or 0-10V analog output with 10-bits resolution mirroring the actual flowrate. Flowrate levels as well as the minimum and maximum signal output can be tuned.

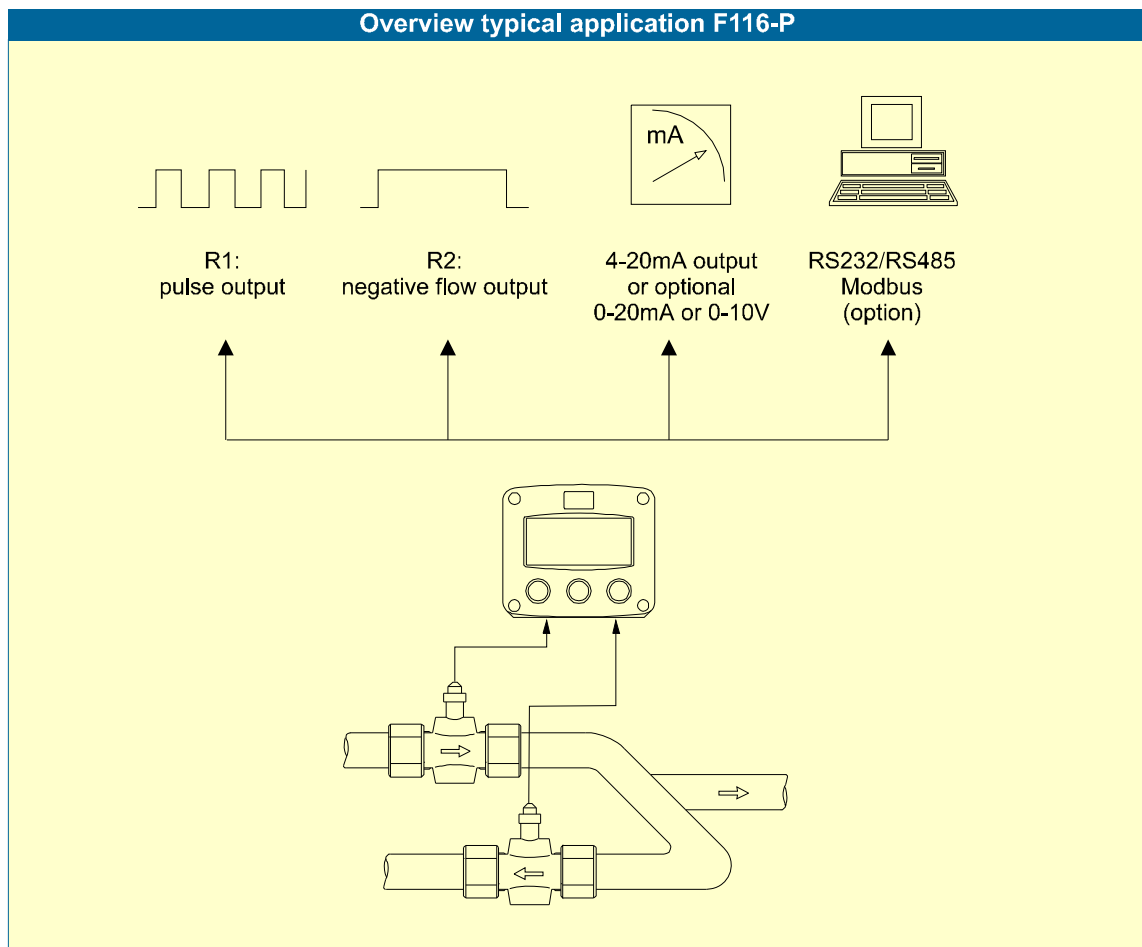

Fig. 1: Typical application for the F116-P.

### **Configuration of the unit**

The F116-P was designed to be implemented in many types of applications. For that reason, a SETUP-level is available to configure your F116-P according to your specific requirements. SETUP includes several important features, such as K-factors, measurement units, signal selection etc. All settings are stored in EEPROM memory and will not be lost in the event of power failure or a drained battery.

To extend the battery-life time (option), please make use of the power-management functions as described in chapter 3.2.3.

### **Display information**

The unit has a large transfective LCD with all kinds of symbols and digits to display measuring units, status information, trend-indication and key-word messages.

Differential or sum Flowrate and totals can be displayed either with the small 8mm digits or with the 17mm digits. The flowrate and accumulated total of flow A and flow B can be displayed as well.

A backup of the total and accumulated total in EEPROM memory is made every minute.

### **Options**

The following options are available: isolated or active 4-20mA / 0-10V / 0-20mA analog output, full Modbus communication RS232/485/TTL (also battery powered), intrinsic safety, mechanical relay or active output, power- and sensor-supply options, panel-mount, wall-mount and weather-proof enclosures, flame proof enclosure and LED backlight.

## 2. OPERATIONAL

### 2.1. GENERAL



- *The F116-P may only be operated by personnel who are authorized and trained by the operator of the facility. All instructions in this manual are to be observed.*
- *Take careful notice of the " Safety rules, instructions and precautionary measures " in the front of this manual.*

This chapter describes the daily use of the F116-P. This instruction is meant for users / operators.

### 2.2. CONTROL PANEL

The following keys are available:

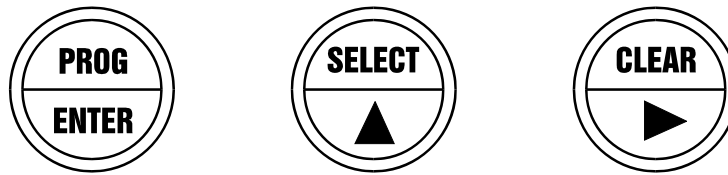

Fig. 2: Control Panel.

#### Functions of the keys



This key is used to program and save new values or settings.  
It is also used to gain access to SETUP-level; please read chapter 3.



This key is used to SELECT differential or sum accumulated total, flowrate A and B and accumulated total A and B.  
The arrow-key ▲ is used to increase a value after PROG has been pressed or to configure the unit; please read chapter 3.



Press this key twice to CLEAR the value for total.  
The arrow-key ► is used to select a digit after PROG has been pressed or to configure the unit; please read chapter 3.

### 2.3. OPERATOR INFORMATION AND FUNCTIONS

In general, the F116-P will always act at Operator level. The information displayed is dependant upon the SETUP-settings. All pulses generated by the connected flowmeter are measured by the F116-P in the background, whichever screen refresh rate setting is chosen. After pressing a key, the display will be updated very quickly during a 30 second period, after which it will slow-down again.



Fig. 3: Example of display information during process.

For the Operator, the following functions are available:

- **Display flowrate / total or flowrate**  
 This is the main display information of the F116-P. After selecting any other information, it will always return to this main display automatically.  
 The calculated Total (differential or sum) is displayed on the upper-line of the display and the calculated flowrate on the bottom line. It is possible to display flowrate only with the large 17mm digits; in this instance press the SELECT-key to read the total.  
 A negative flowrate might be displayed as soon as the returned flow - measured with flowmeter B - is more as the input flow.  
 When "-----" is shown, then the flowrate value is too high to be displayed. The arrows  $\blacklozenge$  indicate the increase/decrease of the flowrate trend.
- **Clear total**  
 The value for total can be re-initialized. To do so, press CLEAR twice. After pressing CLEAR once, the flashing text "PUSH CLEAR" is displayed. To avoid re-initialization at this stage, press another key than CLEAR or wait for 20 seconds.  
 Re-initialization of total DOES NOT influence the accumulated total.
- **Display accumulated total**  
 When the SELECT-key is pressed, the calculated total and accumulated total are displayed. The accumulated total cannot be re-initialized. The value will count up to 99,999,999,999. The unit and number of decimals are displayed according to the configuration settings for total.
- **Display flowrate / accumulated total flow A and B**  
 If enabled with the configuration of the F116-P, the actual flows and accumulated totals for flow A and B will be displayed after pressing SELECT several times.
- **Low-battery alarm**  
 When the battery voltage drops, it must be replaced. At first "low-battery" will flash, but as soon as it is displayed continuously, the battery MUST be replaced shortly after!  
 Only original batteries supplied by the manufacturer may be used, else the guarantee and liability will be terminated. The remaining lifetime after the first moment of indication is generally several days up to some weeks.



Fig. 4: Example of low-battery alarm.

- **Alarm**  
 When "alarm" is displayed, please consult Appendix B: problem solving.



### 3. CONFIGURATION

#### 3.1. INTRODUCTION

This and the following chapters are exclusively meant for electricians and non-operators. In these, an extensive description of all software settings and hardware connections are provided.



Caution !

- *Mounting, electrical installation, start-up and maintenance of the instrument may only be carried out by trained personnel authorized by the operator of the facility. Personnel must read and understand this Operating Manual before carrying out its instructions.*
- *The F116-P may only be operated by personnel who are authorized and trained by the operator of the facility. All instructions in this manual are to be observed.*
- *Ensure that the measuring system is correctly wired up according to the wiring diagrams. The housing may only be opened by trained personnel.*
- *Take careful notice of the " Safety rules, instructions and precautionary measures " in the front of this manual.*

#### 3.2. PROGRAMMING SETUP-LEVEL

##### 3.2.1. GENERAL

Configuration of the F116-P is done at SETUP-level. SETUP-level is reached by pressing the PROG/ENTER key for 7 seconds; at which time, both arrows  will be displayed. In order to return to the operator level, PROG will have to be pressed for three seconds. Alternatively, if no keys are pressed for 2 minutes, the unit will exit SETUP automatically. SETUP can be reached at all times while the F116-P remains fully operational.



Note !

**Note:** A pass code may be required to enter SETUP. Without this pass code access to SETUP is denied.

To enter SETUP-level:

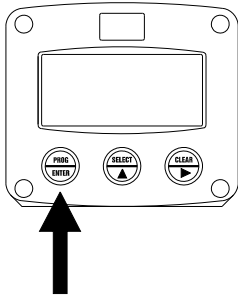

Press  for 7 seconds

**Matrix structure SETUP-level:**

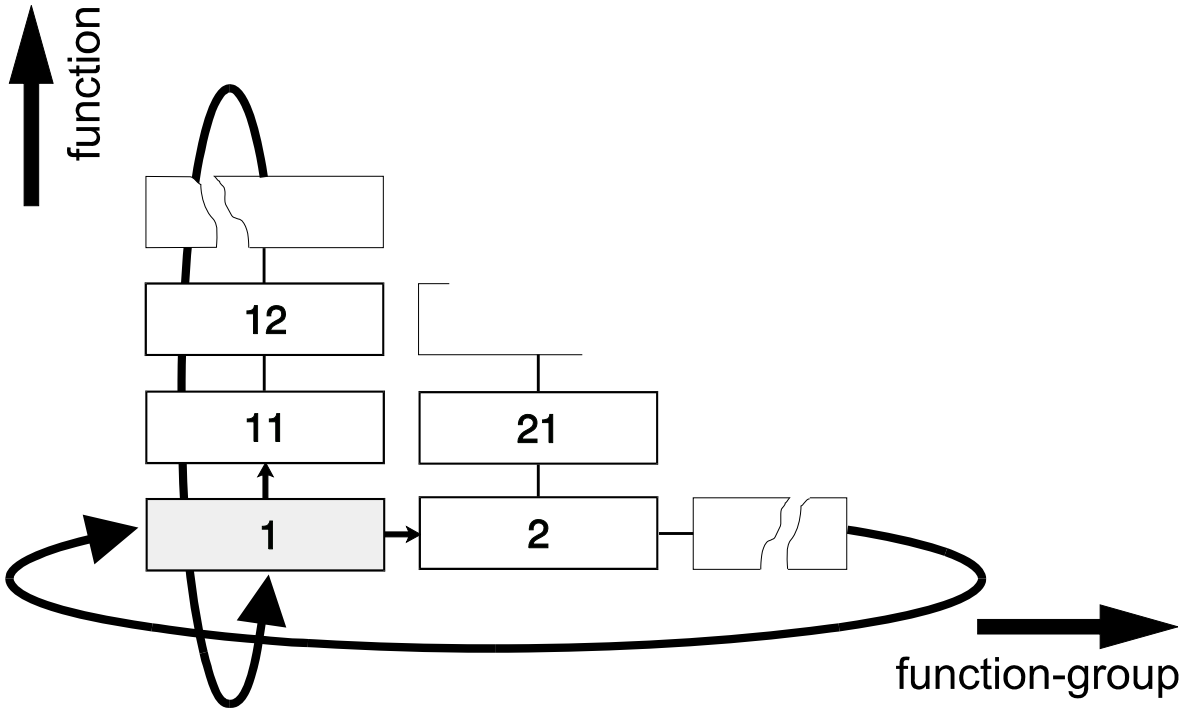

**SCROLLING THROUGH SETUP-LEVEL**

**Selection of function-group and function:**

SETUP is divided into several function groups and functions.

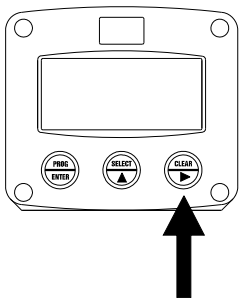

Select function-group with

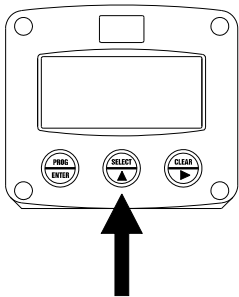

Select function with







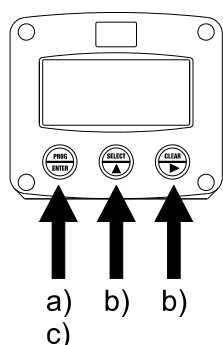

Each function has a unique number, which is displayed below the word "SETUP" at the bottom of the display. The number is a combination of two figures. The first figure indicates the function-group and the second figure the sub-function. Additionally, each function is expressed with a keyword.



After selecting a sub-function, the next main function is selected by scrolling through all "active" sub-functions (e.g. 1<sup>▲</sup>, 11<sup>▲</sup>, 12<sup>▲</sup>, 13<sup>▲</sup>, 14<sup>▲</sup>, 1<sup>▶</sup>, 2<sup>▶</sup>, 3<sup>▲</sup>, 31 etc.).



To change or select a value:



- a) press  briefly; **PROGRAM** will start flash
- b) select or enter value with  and / or 
- c) press  to confirm the value / selection.

To change a value, use  to select the digits and  to increase that value.

To select a setting, both  and  can be used.

If the new value is invalid, the increase sign  or decrease-sign  will be displayed while you are programming.

When data is altered but ENTER is not pressed, then the alteration can still be cancelled by waiting for 20 seconds or by pressing ENTER for three seconds: the PROG-procedure will be left automatically and the former value reinstated.



Note !

**Note:** alterations will only be set after ENTER has been pressed!

To return to OPERATOR-level:

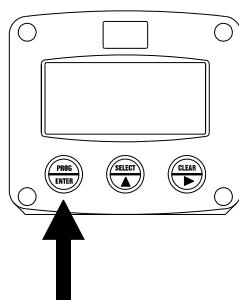

Press  for 3 seconds

In order to return to the operator level, PROG will have to be pressed for three seconds. Also, when no keys are pressed for 2 minutes, SETUP will be left automatically.

## 3.2.2. OVERVIEW FUNCTIONS SETUP LEVEL

<b>SETUP FUNCTIONS AND VARIABLES</b>			
<b>1</b>	<b>TOTAL A</b>		
11	UNIT	L - m3 - kg - lb - GAL - USGAL - bbl - no unit	
12	DECIMALS	0 - 1 - 2 - 3 (Ref: displayed value)	
13	K-FACTOR:	0.000010 - 9,999,999	
14	DECIMALS K-FACTOR	0 - 6	
<b>2</b>	<b>FLOWRATE A</b>		
21	UNIT	mL, L, m3, mg, g, kg, ton, GAL, bbl, lb, cf, rev, no unit	
22	TIME UNIT	sec - min - hour - day	
23	DECIMALS	0 - 1 - 2 - 3 (Ref: displayed value)	
24	K-FACTOR	0.000010 - 9,999,999	
25	DECIMALS K-FACTOR	0 - 6	
26	FILTER	1 - 99	
27	PERIOD	0.1 - 99.9 seconds	
<b>3</b>	<b>TOTAL B</b>		
31	K-FACTOR	0.000010 - 9,999,999	
32	DECIMALS K-FACTOR	0 - 6	
<b>4</b>	<b>FLOWRATE B</b>		
41	K-FACTOR	0.000010 - 9,999,999	
42	DECIMALS K-FACTOR	0 - 6	
<b>5</b>	<b>DISPLAY</b>		
51	FUNCTION	total - flowrate - all	
52	CALCULATE	differential - add	
53	MEASUREMENT	bi-directional - not negative - threshold - stationary	
54	STATIONARY FLOWRATE	0000.000 - 9999999 units/time unit	
55	STATIONARY TOTAL	0000.000 - 9999.999 units/hr	
<b>6</b>	<b>POWER MANAGEMENT</b>		
61	LCD UPDATE	fast - 1 sec - 3 sec - 15 sec - 30 sec - off	
62	BATTERY MODE	operational - shelf	
<b>7</b>	<b>FLOWMETER</b>		
71	SIGNAL A	npn - npn_lp - reed - reed_lp - pnp - pnp_lp - namur - coil_hi - coil_lo - act_8.1 - act_12 - act_24	
72	SIGNAL B	npn - npn_lp - reed - reed_lp - pnp - pnp_lp - namur - coil_hi - coil_lo - act_8.1 - act_12 - act_24	
<b>8</b>	<b>ANALOG</b>		
81	OUTPUT	disable - enable	
82	MINIMUM SIGNAL	0000.000 - 9,999,999 unit/time unit	
83	MAXIMUM SIGNAL	0000.000 - 9,999,999 unit/time unit	
84	CUT-OFF	0.0 - 9.9%	
85	TUNE MIN - 4mA / 0V	0 - 9,999	
86	TUNE MAX- 20mA / 10V	0 - 9,999	
87	FILTER	00 - 99	
<b>9</b>	<b>IMPULSE</b>		
91	PERIOD TIME	0 - 250	
92	IMPULSE PER	X,XXX,XXX quantity	
<b>A</b>	<b>COMMUNICATION</b>		
A1	SPEED / BAUDRATE	1200 - 2400 - 4800 - 9600	
A2	ADDRESS	1 - 255	
A3	MODE	RTU - off	
<b>B</b>	<b>OTHERS</b>		
B1	TYPE / MODEL	F116-P	
B2	SOFTWARE VERSION		
B3	SERIAL NO.		
B4	PASSWORD	0000 - 9999	
B5	TAGNUMBER	0000000 - 9999999	

## 3.2.3. EXPLANATION OF SETUP-FUNCTIONS

1 - TOTAL A	
<b>MEASUREMENT UNIT 11</b>	<p>SETUP - 11 determines the measurement unit for total, accumulated total and pulse output for BOTH A and B. The following units can be selected:</p> <p style="text-align: center;">L - m3 - kg - lb. - GAL - USGAL - bbl - _ (no unit).</p> <p>Alteration of the measurement unit will have consequences for operator and SETUP-level values. Please note that the K-factor has to be adapted as well; the calculation is not done automatically.</p>
<b>DECIMALS 12</b>	<p>The decimal point determines for total, accumulated total and pulse output the number of digits following the decimal point for BOTH A and B. The following can be selected:</p> <p style="text-align: center;">0000000 - 111111.1 - 22222.22 - 3333.333</p>
<b>K-FACTOR 13</b>	<p>With the K-factor, the flowmeter pulse signals are converted to a quantity. The K-factor is based on the number of pulses generated by the flowmeter per selected measurement unit (SETUP 11), for example per cubic meter. The more accurate the K-factor, the more accurate the functioning of the system will be.</p> <p><b>Example 1: Calculating the K-factor.</b> <i>Let us assume that the flowmeter generates 2.4813 pulses per liter and the selected unit is "cubic meters / m3". A cubic meter consists of 1000 parts of one liter which implies 2,481.3 pulses per m3. So, the K-factor is 2,481.3. Enter for SETUP - 13: "2481300" and for SETUP - 14 - decimals K-factor "3".</i></p> <p><b>Example 2: Calculating the K-factor.</b> <i>Let us assume that the flowmeter generates 6.5231 pulses per gallon and the selected measurement unit is gallons. So, the K-Factor is 6.5231. Enter for SETUP - 13: "6523100" and for SETUP - 14 decimals K-factor "6".</i></p>
<b>DECIMALS K-FACTOR 14</b>	<p>This setting determines the number of decimals for the K-factor entered. (SETUP 13). The following can be selected:</p> <p style="text-align: center;">0 - 1 - 2 - 3 - 4 - 5 - 6</p> <p>Please note that this setting influences the accuracy of the K-factor indirectly. (i.e. the position of the decimal point and thus the value given) This setting has NO influence on the displayed number of digits for total (SETUP 12)!</p>

## 2 - FLOWRATE A

The settings for total and flowrate are entirely separate. In this way, different units of measurement can be used for each e.g. cubic meters for total and liters for flowrate.  
The display update time for flowrate is one second or more.

**Note:** *these settings also influence the analog output.*

<b>MEASUREMENT UNIT 21</b>	SETUP - 21 determines the measurement unit for flowrate for BOTH A and B.  mL - L - m3 - mg - gr - kg - ton - GAL - bbl - lb - cf - rev (revolutions for RPM) - _ (no unit).  Alteration of the measurement unit will have consequences for operator and SETUP-level values. Please note that the K-factor has to be adapted as well; the calculation is not done automatically.			
<b>TIME UNIT 22</b>	The flowrate can be calculated per second (SEC), minute (MIN), hour (HR) or day (DAY). This selection is valid for BOTH A and B flow.			
<b>DECIMALS 23</b>	This setting determines for flowrate the number of digits following the decimal point for BOTH A and B. The following can be selected:  00000 - 1111.1 - 2222.22 - 3333.333			
<b>K-FACTOR 24</b>	With the K-factor, the flowmeter pulse signals are converted to a flowrate. The K-factor is based on the number of pulses generated by the flowmeter per selected measurement unit (SETUP 21), for example per liter. The more accurate the K-factor, the more accurate the functioning of the system will be. For examples read SETUP 13.			
<b>DECIMALS K-FACTOR 25</b>	This setting determines the number of decimals for the K-factor (SETUP 24). The following can be selected:  0 - 1 - 2 - 3 - 4 - 5 - 6  Please note that this SETUP - influences the accuracy of the K-factor indirectly. This setting has NO influence on the displayed number of digits for "flowrate" (SETUP 23)!			
<b>FILTER 26</b>	This function is used to stabilize the flowrate reading. With the help of this digital filter a more stable but less actual reading can be obtained. The filter principal is based on three input values: the filter level (01-99), the last calculated flowrate on both the A / B flow and the last average value. The higher the filter level, the longer the response time on a value change will be. Below, several filter levels with there response times are indicated:			
<b>FILTER VALUE</b>	<b>RESPONSE TIME ON STEP CHANGE OF ANALOG VALUE. TIME IN SECONDS</b>			
	<b>50% INFLUENCE</b>	<b>75% INFLUENCE</b>	<b>90% INFLUENCE</b>	<b>99% INFLUENCE</b>
01	filter disabled	filter disabled	filter disabled	filter disabled
02	0.1 second	0.2 second	0.4 second	0.7 second
03	0.2 second	0.4 second	0.6 second	1.2 seconds
05	0.4 second	0.7 second	1.1 seconds	2.1 seconds
10	0.7 second	1.4 seconds	2.2 seconds	4.4 seconds
20	1.4 seconds	2.8 seconds	4.5 seconds	9.0 seconds
30	2.1 seconds	4 seconds	7 seconds	14 seconds
50	3.5 seconds	7 seconds	11 seconds	23 seconds
75	5.2 seconds	10 seconds	17 seconds	34 seconds
99	6.9 seconds	14 seconds	23 seconds	45 seconds

Continued next page >>>

## 2 - FLOWRATE A (CONTINUED)

<b>PERIOD</b> 27	<p>The flowrate is calculated by counting the number of pulses within a certain time, for example 1 second. The longer the time the more accurate the flowrate will be. The maximum value is 999.9 seconds.</p> <p><b>Note:</b> <i>this setting does influence the update time for the analog output directly (maximum update 10 times a second). If the output response is too slow, decrease the number of pulses.</i></p> <p><b>Note:</b> <i>the shorter the time, the higher the power consumption of the unit will be (important for battery powered applications).</i></p>
---------------------	--



Note !

## 3 - TOTAL B

<b>K-FACTOR</b> 31	<p>With the K-factor, the flowmeter pulse signals are converted to a quantity. The K-factor is based on the number of pulses generated by the flowmeter per selected measurement unit (SETUP 11), for example per cubic meter. The more accurate the K-factor, the more accurate the functioning of the system will be.</p> <p>For examples: please read SETUP 13</p>
<b>DECIMALS K-FACTOR</b> 32	<p>This setting determines the number of decimals for the K-factor (SETUP 31). The following can be selected:</p> <p style="text-align: center;">0 - 1 - 2 - 3 - 4 - 5 - 6</p> <p>Please note that this function influences the accuracy of the K-factor indirectly.</p>

## 4 - FLOWRATE B

<b>K-FACTOR</b> 41	<p>With the K-factor, the flowmeter pulse signals are converted to a flowrate. The K-factor is based on the number of pulses generated by the flowmeter per selected measurement unit (SETUP 21), for example per liter. The more accurate the K-factor, the more accurate the functioning of the system will be. For examples read SETUP 13.</p>
<b>DECIMALS K-FACTOR</b> 42	<p>This setting determines the number of decimals for the K-factor (SETUP 24). The following can be selected:</p> <p style="text-align: center;">0 - 1 - 2 - 3 - 4 - 5 - 6</p> <p>Please note that this SETUP - influences the accuracy of the K-factor indirectly.</p>

<b>5 - DISPLAY</b>	
<b>FUNCTION 51</b>	The operator information can be set to: <b>TOTAL:</b> the differential total and flowrate will be displayed simultaneously. Press SELECT to display the acc total. <b>FLOWRATE:</b> only the flowrate will be displayed. First after pressing the SELECT the total and acc. total will be displayed. <b>ALL:</b> As FLOWRATE. After pressing SELECT several times, flowrate A, Total A, flowrate B and Total B will be displayed as well.
<b>CALCULATE 52</b>	The unit can be set to calculate and display either the differential total / flowrate or to add (sum function) both flows.
<b>MEASUREMENT 53</b>	To solve undesired display readings during low or even negative consumption situations, four different measurement methods have been implemented. Be aware that the selection does influence the analog output value (ref. flowrate) as well.  <b>bi-directional</b> <u>Displayed flowrate:</u> positive and negative <u>Displayed total:</u> positive and negative  <b>not negative</b> <u>Displayed flowrate:</u> only positive or zero <u>Displayed total:</u> positive and negative  <b>threshold</b> <u>Displayed flowrate:</u> as soon as the flowrate is lower as setting 54 or negative, flowrate zero will be displayed. <u>Displayed total:</u> as soon as the flowrate is lower as setting 54 or negative, totalisation will stop.  <b>stationary</b> <u>Displayed flowrate:</u> as soon as the flowrate is lower as setting 54 or negative, the stationary flowrate (setting 54) will be displayed. <u>Displayed total:</u> as soon as the flowrate is lower as setting 54 or negative, stationary totalisation (setting 55) will be activated. However, if the value of setting 55 is zero, totalisation will be positive and negative.
<b>STATIONARY FLOWRATE 54</b>	Enter here the flowrate according setting 53 - threshold or stationary. The time and measuring units are according to FLOWRATE - setting 21 and 22. <u>In case of selection "threshold":</u> flowrate zero will be displayed as soon as the flowrate will be lower as this setting. <u>In case of selection "stationary":</u> as soon as the flowrate is lower as this setting, this flowrate will be displayed. However, if the flowmeters do not generate pulses, the displayed flowrate will be zero
<b>STATIONARY TOTAL 55</b>	Enter here a flowrate per hour according setting 53 - stationary. The measuring unit is according to TOTAL - setting 11. This flowrate is converted to a total which will be used as long as the flowrate is lower as setting 54. However, if the flowmeters do not generate pulses, the totalisation will stop. This function is disabled if value zero has been entered.



## 6 - POWER MANAGEMENT

When used with the internal battery option, the user can expect reliable measurement over a long period of time. The F116-P has several smart power management functions to extend the battery life time significantly. Two of these functions can be set:

### LCD NEW 61

The calculation of the display-information influences the power consumption significantly. When the application does not require a fast display update, it is **strongly advised** to select a slow refresh rate. Please understand that NO information will be lost; every pulse will be counted and the output signals will be generated in the normal way. The following can be selected:

Fast - 1 sec - 3 sec - 15 sec - 30 sec - off.

**Example 3: Battery life-time**

*battery life-time with a coil pick-up, 1KHz. pulses and FAST update: about 2 years.*

*battery life-time with a coil pick-up, 1KHz. pulses and 1 sec update: about 5 years.*

**Note:** after a button has been pressed by the operator - the display refresh rate will always switch to FAST for 30 seconds. When "OFF" is selected, the display will be switched off after 30 seconds and will be switched on as soon as a button has been pressed.

### BATTERY-MODE 62

The unit has two modes: operational or shelf. After "shelf" has been selected, the unit can be stored for several years; it will not count pulses, the display is switched off but all settings and totals are stored. In this mode, power consumption is extremely low. To wake up the unit again, press the SELECT-key twice.



Note !

## 7 - FLOWMETER



Note !

**SIGNAL A  
71**

The F116-P is able to handle several types of input signal. The type of flowmeter pickup / signal for input A is selected with SETUP 71.  
**Note:** The selections "active pulse" offer a detection level of 50% of the supply voltage.  
 Read also par. 4.4.3. Flowmeter input terminal 09-11.



Note !

**SIGNAL B  
72**

The F116-P is able to handle several types of input signal. The type of flowmeter pickup / signal for input B is selected with SETUP 72.  
**Note:** The selections "active pulse" offer a detection level of 50% of the supply voltage.  
 Read also par. 4.4.3. Flowmeter input terminal 12-14.

TYPE OF SIGNAL	EXPLANATION	RESISTANCE	FREQ. / MV	REMARK
NPN	NPN input	100K pull-up	6 kHz.	(open collector)
NPN - LP	NPN input with low pass filter	100K pull-up	2.2 kHz.	(open collector) less sensitive
REED	Reed-switch input	1M pull-up	1.2 kHz.	
REED - LP	Reed-switch input with low pass filter	1M pull-up	120 Hz.	Less sensitive
PNP	PNP input	100K pull-down	6 kHz.	
PNP - LP	PNP input with low pass filter	100K pull-down	700 Hz.	Less sensitive
NAMUR	Namur input	820 Ohm pull-down	4 kHz.	External power required
COIL HI	High sensitive coil input	-	20mV p.t.p.	Sensitive for disturbance!
COIL LO	Low sensitive coil input	-	90mV p.t.p.	Normal sensitivity
ACT_8.1	Active pulse input 8.1 VDC	3K9	10KHz.	External power required
ACT_12	Active pulse input 12 VDC	4K	10KHz.	External power required
ACT_24	Active pulse input 24 VDC	3K	10KHz.	External power required

## 8 - ANALOG OUTPUT

A linear analog (0)4-20mA or 0-10V signal is generated according to the calculated differential or sum flowrate with a 10 bits resolution. The settings for flowrate (SETUP - 2) influence the analog output directly.

The relationship between rate and analog output is set with the following functions:

<b>DISABLE / ENABLE</b> <b>81</b>	The analog output can be disabled. 3.5mA will be generated if a power supply is available but the output is disabled (this is not valid in case type AB or AU has been supplied).
<b>MINIMUM FLOWRATE</b> <b>82</b>	Enter here the flowrate at which the output should generate the minimum signal (0/4mA or 0V) - in most applications at flowrate "zero". The number of decimals displayed depend upon SETUP 23. The time and measuring units (L/min for example) are dependant upon SETUP 21 and 22 but are not displayed.
<b>MAXIMUM FLOWRATE</b> <b>83</b>	Enter here the flowrate at which the output should generate the maximum signal (20mA or 10V) - in most applications at maximum flow. The number of decimals displayed depend upon SETUP 23. The time and measuring units (L/min for example) are dependant upon SETUP 21 and 22 but can not be displayed.
<b>CUT-OFF</b> <b>84</b>	To ignore leakage of the flow for example, a low flow cut-off can be set as a percentage of the full range of 16mA (or 20mA / 10V). When the flow is less than the required rate, the current will be 4mA. <b>Examples:</b>

4mA (SETUP 82)	20mA (SETUP 83)	CUT-OFF (SETUP 84)	REQUIRED RATE	OUTPUT
0 L/min	100 L/min	2%	$(100-0)*2\% = 2.0 \text{ L/min}$	$4+(16*2\%) = 4.32\text{mA}$
20 L/min	800 L/min	3.5%	$(800-20)*3.5\% = 27.3 \text{ L/min}$	$4+(16*3.5\%) = 4.56\text{mA}$

<b>TUNE MIN / 4MA</b> <b>85</b>	<p>The initial minimum analog output value is 0/4mA or 0V. However, this value might differ slightly due to external influences such as temperature for example. The 0/4mA or 0V value can be tuned precisely with this setting.</p> <ul style="list-style-type: none"> <li>▪ <b><i>Before tuning the signal, be sure that the analog signal is not being used for any application!</i></b></li> </ul> <p>After pressing PROG, the current will be about 4mA (or 0mA / 0V). The current can be increased / decreased with the arrow-keys and is <u>directly active</u>. Press ENTER to store the new value. Remark: the analog output value can be programmed "up-side-down" if desired, so 20mA at minimum flowrate for example!</p>
<b>TUNE MAX / 20MA</b> <b>86</b>	<p>The initial maximum analog output value is 20mA (or 10V). However, this value might differ slightly due to external influences such as temperature for example. The 20mA value (or 10V) can be tuned precisely with this setting.</p> <ul style="list-style-type: none"> <li>▪ <b><i>Before tuning the signal, be sure that the analog signal is not being used for any application!</i></b></li> </ul> <p>After pressing PROG, the current will be about 20mA. The current can be increased / decreased with the arrow-keys and is <u>directly active</u>. Press ENTER to store the new value. Remark: the analog output value can be programmed "up-side-down" if desired, so 4mA at maximum flowrate for example!</p>

Continued next page >>>



Note !



## 8 - ANALOG OUTPUT (CONTINUED)

<b>FILTER 87</b>	<p>This function is used to stabilize the analog output signal. The output value is updated every 0.1 second. With the help of this digital filter a more stable but less precise reading can be obtained.</p> <p>The filter principal is based on three input values: the filter level (01-99), the last analog output value and the last average value. The higher the filter level, the longer the response time on a value change will be. Below, several filter levels with their response times are indicated:</p>			
<b>FILTER VALUE</b>	<b>RESPONSE TIME ON STEP CHANGE OF ANALOG VALUE.</b>			
	<b>TIME IN SECONDS</b>			
	<b>50% INFLUENCE</b>	<b>75% INFLUENCE</b>	<b>90% INFLUENCE</b>	<b>99% INFLUENCE</b>
01	filter disabled	filter disabled	filter disabled	filter disabled
02	0.1 second	0.2 second	0.4 second	0.7 second
03	0.2 second	0.4 second	0.6 second	1.2 seconds
05	0.4 second	0.7 second	1.1 seconds	2.1 seconds
10	0.7 second	1.4 seconds	2.2 seconds	4.4 seconds
20	1.4 seconds	2.8 seconds	4.5 seconds	9.0 seconds
30	2.1 seconds	4 seconds	7 seconds	14 seconds
50	3.5 seconds	7 seconds	11 seconds	23 seconds
75	5.2 seconds	10 seconds	17 seconds	34 seconds
99	6.9 seconds	14 seconds	23 seconds	45 seconds

## 9 - RELAY OUTPUT

One transistor or mechanic relay output is available as scaled pulse output according to the calculated differential or sum total.

**PERIOD TIME  
PULSE OUTPUT  
91**

The period time determines the time that the transistor or relay will be switched; in other words the pulse length. The minimum time between the pulses is as long as the selected period time.

One period is approx. 7.8 msec. If the value selected is "zero", the pulse output is disabled. The maximum value is 255 periods.

***Note:** If the frequency should go out of range - when the flowrate increases for example - an internal buffer will be used to "store the missed pulses": As soon as the flowrate reduces again, the buffer will be "emptied".*

*It might be that pulses will be missed due to a buffer-overflow, so it is advised to program this setting within it's range.*

*If a mechanic relay is used for the pulse output, it is recommended to reduce the max. output frequency to 0.5Hz, else the life time will be reduced significantly.*

NUMBER OF PERIODS	PERIOD TIME	MAX. FREQUENCY
0	disabled	disabled
1	0,0078 seconds	64 Hz.
2	0,0156 seconds	32 Hz.
3	0,0234 seconds	21 Hz.
64	0,5000 seconds	1 Hz.
255	1,9922 seconds	0.25 Hz.

**PULSE PER  
92**

According to the measurement unit settings for total, a pulse will be generated every X-quantity. Enter this quantity here while taking the displayed decimal position and measuring unit into account.



Note !

## A - COMMUNICATION (OPTIONAL)

The functions described below deal with hardware that is not part of the standard delivery. Programming of these functions does not have any effect if this hardware has not been installed. Consult Appendix C and the Modbus communication protocol description for a detailed explanation.	
<b>BAUDRATE A1</b>	For external control, the following communication speeds can be selected:  1200 - 2400 - 4800 - 9600 baud
<b>BUS ADDRESS A2</b>	For communication purposes, a unique identity can be attributed to every F116-P. This address can vary from 1-255.
<b>MODE A3</b>	The communication protocol is Modbus RTU mode. Select OFF, to disable this communication function.

## B - OTHERS

<b>TYPE OF MODEL B1</b>	For support and maintenance it is important to have information about the characteristics of the F116-P. Your supplier will ask for this information in the case of a serious breakdown or to assess the suitability of your model for upgrade considerations.
<b>VERSION SOFTWARE B2</b>	For support and maintenance it is important to have information about the characteristics of the F116-P. Your supplier will ask for this information in the case of a serious breakdown or to assess the suitability of your model for upgrade considerations.
<b>SERIAL NUMBER B3</b>	For support and maintenance it is important to have information about the characteristics of the F116-P. Your supplier will ask for this information in the case of a serious breakdown or to assess the suitability of your model for upgrade considerations.
<b>PASS CODE B4</b>	All SETUP-values can be pass code protected. This protection is disabled with value 0000 (zero). Up to and including 4 digits can be programmed, for example 1234.
<b>TAGNUMBER B5</b>	For identification of the unit and communication purposes, a unique tag number of maximum 7 digits can be entered.

## 4. INSTALLATION

### 4.1. GENERAL DIRECTIONS



- Mounting, electrical installation, start-up and maintenance of this instrument may only be carried out by trained personnel authorized by the operator of the facility. Personnel must read and understand this Operating Manual before carrying out its instructions.
- The F116-P may only be operated by personnel who are authorized and trained by the operator of the facility. All instructions in this manual are to be observed.
- Ensure that the measuring system is correctly wired up according to the wiring diagrams. Protection against accidental contact is no longer assured when the housing cover is removed or the panel cabinet has been opened (danger from electrical shock). The housing may only be opened by trained personnel.
- Take careful notice of the " Safety rules, instructions and precautionary measures " at the front of this manual.

### 4.2. INSTALLATION / SURROUNDING CONDITIONS

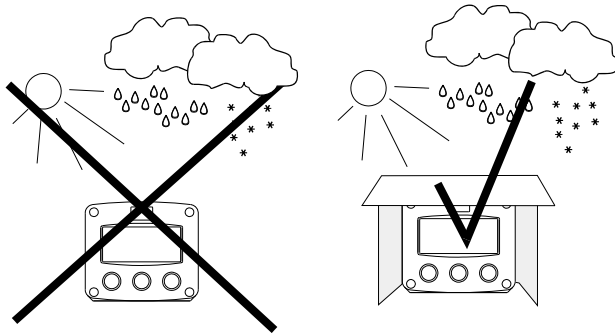

Take the relevant IP classification of the casing into account (see manufactures plate). Even an IP67 (NEMA 4X) casing should NEVER be exposed to strongly varying (weather) conditions.

When panel-mounted, the unit is IP65 (NEMA 4X)!

When used in very cold surroundings or varying climatic conditions, take the necessary precautions against moisture by placing a dry sachet of silica gel, for example, inside the instrument case.

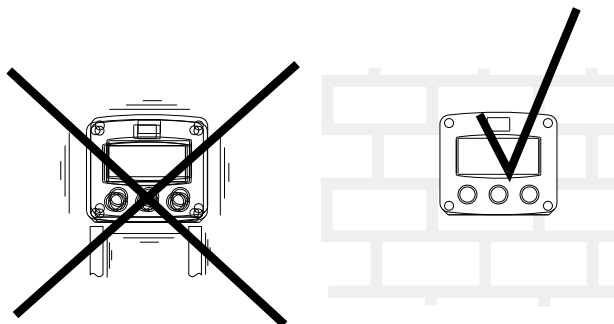

Mount the F116-P on a solid structure to avoid vibrations.

4.3. DIMENSIONS- ENCLOSURE

Aluminum enclosures:

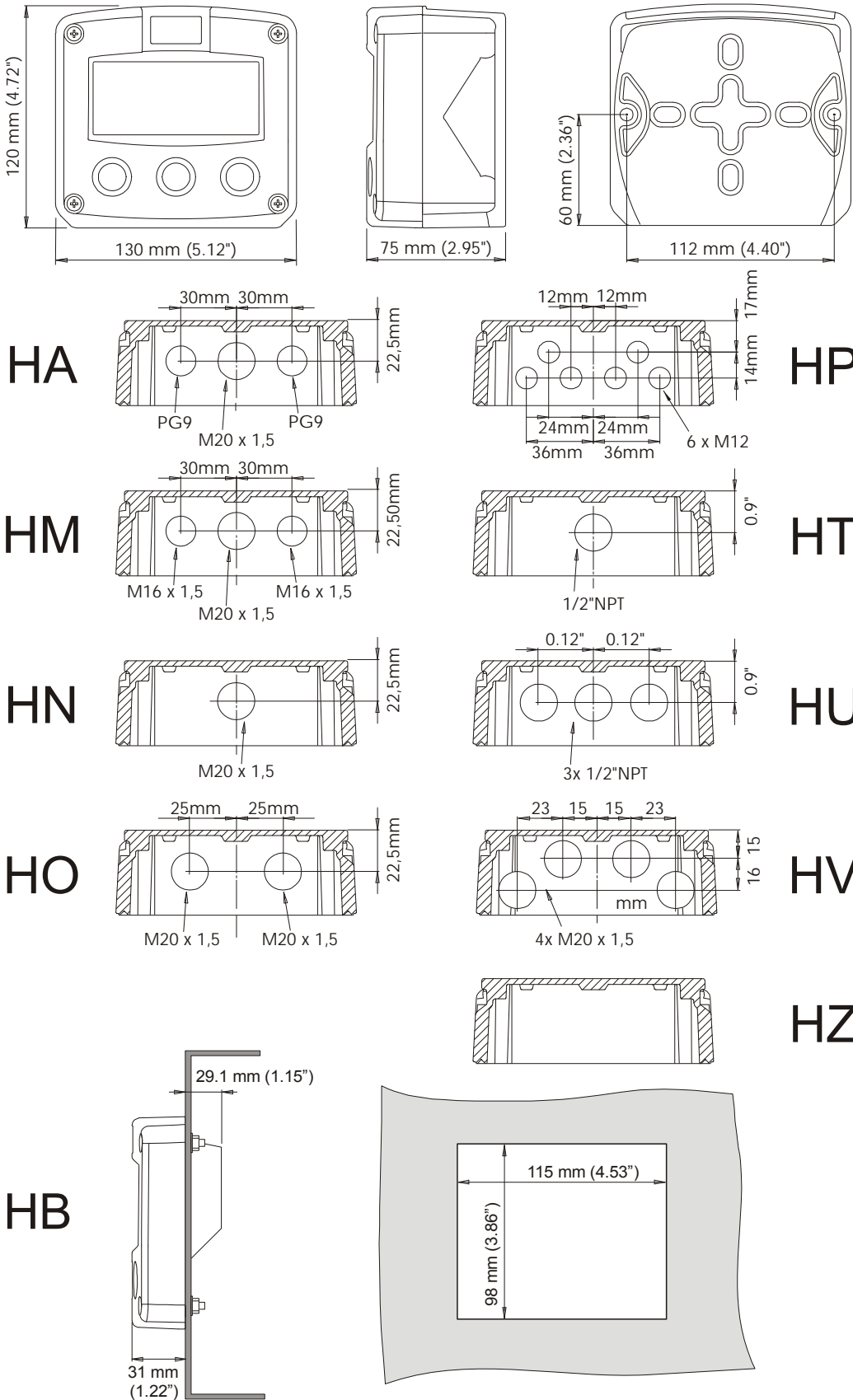
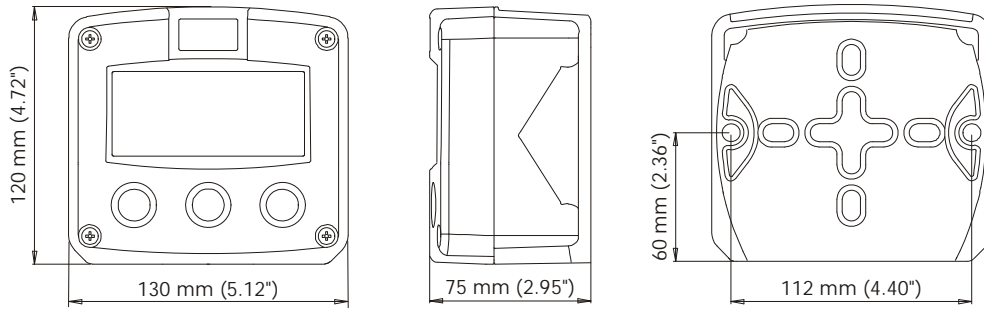

Fig. 5: Dimensions aluminum enclosures

GRP enclosures:



HK back box:  
(flat bottom)

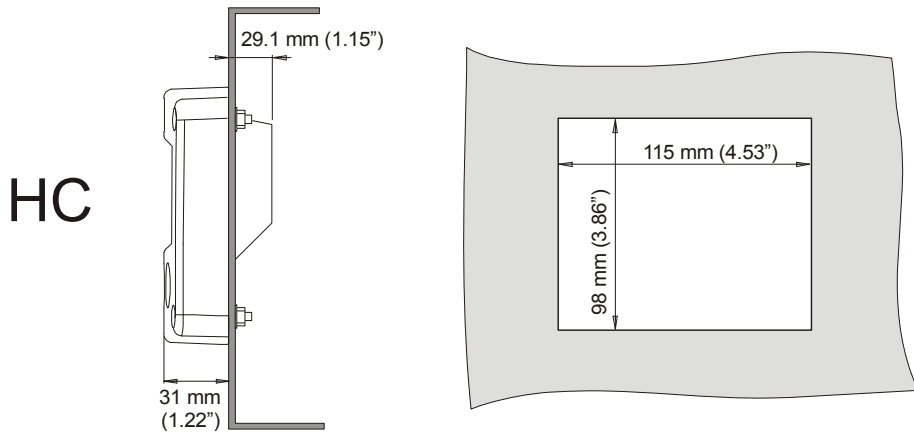
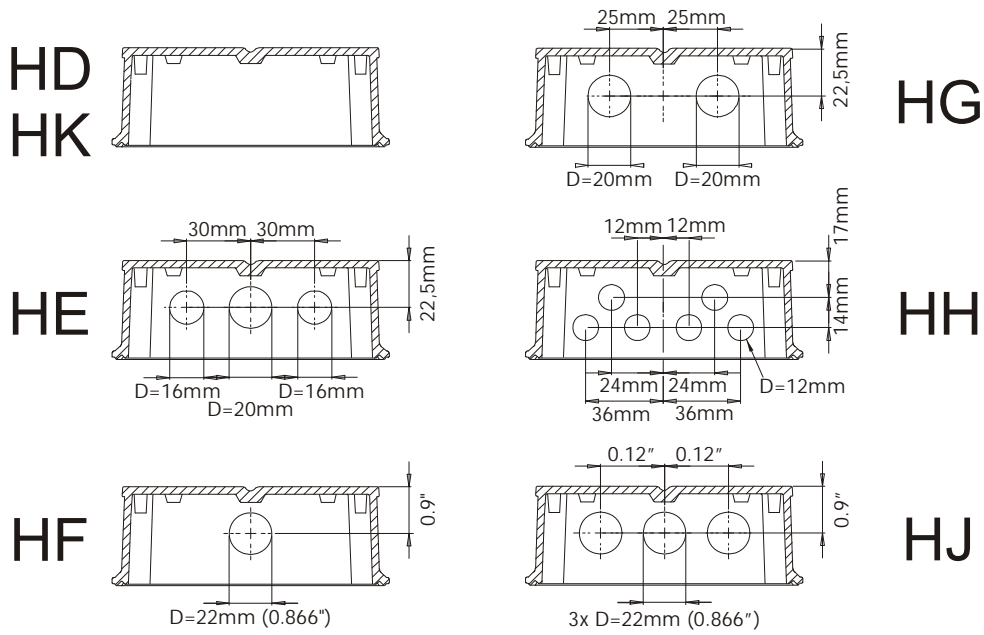
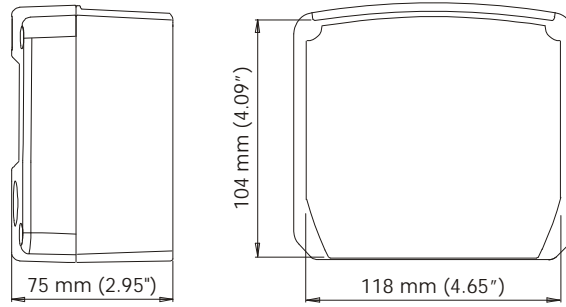

Fig. 6: Dimensions GRP enclosures



#### 4.4. INSTALLING THE HARDWARE



##### 4.4.1. INTRODUCTION

- Electro static discharge does inflict irreparable damage to electronics! Before installing or opening the unit, the installer has to discharge himself by touching a well-grounded object.
- This unit must be installed in accordance with the EMC guidelines (Electro Magnetic Compatibility).



##### Aluminum enclosures

- When installed in an aluminum enclosure and a potentially explosive atmosphere requiring apparatus of equipment protection level Ga and Da, the unit must be installed such that, even in the event of rare incidents, an ignition source due to impact or friction sparks between the enclosure and iron/steel is excluded.
- Do ground the aluminum enclosure properly as indicated, if the F116-P has been supplied with the 115-230V AC power-supply type PM. The green / yellow wire between the back-casing and removable terminal-block may never be removed.

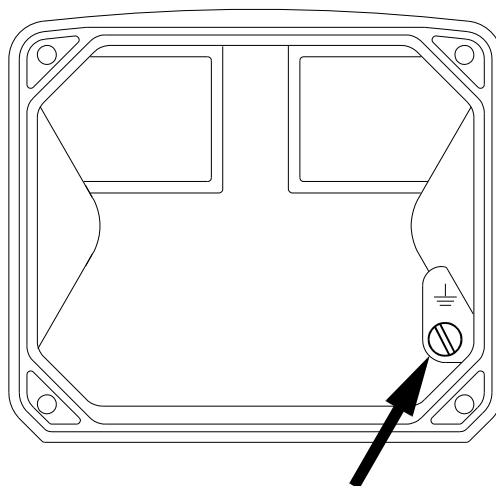

*Fig. 7: Grounding aluminum enclosure with type PM 115-230V AC.*

#### FOR INSTALLATION, PAY EMPHATIC ATTENTION TO:

- Separate cable glands with effective IP67 (NEMA4X) seals for all wires.
- Unused cable entries: ensure that you fit IP67 (NEMA4X) plugs to maintain rating.
- A reliable ground connection for both the sensor, and if applicable, for the metal casing.
- An effective screened cable for the input signal, and grounding of its screen to terminal 9 (GND) or at the sensor itself, whichever is appropriate to the application.

4.4.2. VOLTAGE SELECTION SENSOR SUPPLY

For *Intrinsically Safe* applications: read chapter 5.

**Type PB / PC / PX (AP) - battery powered and output loop-powered applications:**

Terminal 11 provides a limited supply voltage of 3.2 V DC (coil signals 1.2V) for the signal output of the flowmeter.

**Note:** This voltage MAY NOT be used to power the flowmeters electronics, converters etc, as it will not provide adequate sustained power ! All energy used by the flowmeters pick-up will directly influence the battery life-time. It is strongly advised to use a "zero power" pickup such as a coil or reed-switch when operating without external power. It is possible to use some low power NPN or PNP output signals, but the battery life time will be significantly reduced (consult your distributor).



**Type PD / PF / PM: Sensor supply: 1.2 / 3.2V / 8.2V / 12V or 24 V DC:**

With this option, a real power supply for the sensor is available. The flowmeter can be powered with 8.2 / 12 or 24 V DC.

Total power consumption PD: max. 50mA@24V and PF / PM: max. 400mA@24V.

The voltage is selected with the three switches inside the enclosure.

- **Warning:** be sure that all the leads to the terminals are disconnected from the unit when the internal plastic protection cover has been removed !
- **HIGH VOLTAGE 400V !! NEVER connect the mains power supply to the unit when the plastic protection cover has been removed !!!**

First, remove the terminal strip(s) after which the internal plastic cover can be removed. The switches are located in the top left corner (type PD) or on the right hand (type PF / PM) as indicated:

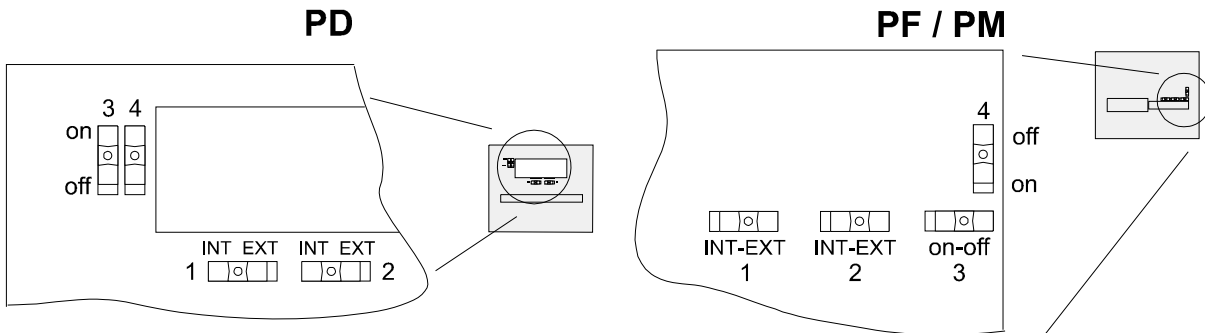

Fig. 8: Switch setting sensor supply voltage.

**Switch positions**

SENSOR A	
SWITCH 1	VOLTAGE
internal	3.2 V DC
external	switch 3+4

SENSOR B	
SWITCH 2	VOLTAGE
internal	3.2 V DC
external	switch 3+4

VOLTAGE SELECTION		
SWITCH 3	SWITCH 4	VOLTAGE
on	on	8.2 V DC
on	off	12 V DC
off	off	23 V DC

- Function switch 1:** voltage selection sensor A - terminal 11.
- Function switch 2:** voltage selection sensor B - terminal 14.
- Function switch 3+4:** the combination of these switches determine the voltage as indicated. If switch 1 and 2 are both set to position OFF than the selected voltage with switch 3+4 is valid for both sensors.

### 4.4.3. TERMINAL CONNECTORS

For Intrinsically Safe applications: read chapter 5.

The following terminal connectors are available:

POWER SUPPLY TYPE PD / PF / PM			NEGATIVE TOTAL OUTPUT R2 TYPE OA/ OT / OR			PULSE OUTPUT R1 TYPE OA/ OT / OR		ANALOG OUTPUT TYPE AA / AB AI / AP / AU POWER SUPPLY TYPE PX		INPUT A: SENSOR SIGNAL TYPE P: PULSE INPUT			INPUT B: SENSOR SIGNAL TYPE P: PULSE INPUT	
GND	1	2	3	4	5	6	7	8	9	10	11	12	13	14
⊥	N	L1	R2 ⊥	R2	R1 ⊥	R1	I ⊥	I ↓	⊥	SIGNAL	+ ↓	⊥	SIGNAL	+ ↓

Fig. 9: Overview of terminal connectors standard configuration F116-P and options.

#### REMARKS: TERMINAL CONNECTORS:

Terminal GND- 01- 02: Power Supply - only available with type PD / PF or PM:

TYPE	SENSOR SUPPLY	Terminal			backlight	TYPE AA	TYPE AU	Type OA	Type OR
		GND	01	02					
PD 8-24V AC	8,2 / 12 / 24V max. 50mA		AC	AC	◇	◇	◇	◇	
PD 8-30V DC	8,2 / 12 / 24V max. 50mA	L-	L+		◇	◇	◇	◇	
PF 24V AC ± 15%	8,2 / 12 / 24V max. 400mA		AC	AC	◇	◇	◇		◇
PF 24V DC ± 15%	8,2 / 12 / 24V max. 400mA	L-	L+		◇	◇	◇		◇
PM 115-230V AC ± 15%	8,2 / 12 / 24V max. 400mA	EARTH	AC	AC	◇	◇	◇	◇	◇
Note PD	do not use a AC autotransformer (Spartrafo) without a galvanic isolation.								
Note PF / PM	The total consumption of the sensors and outputs may not exceed 400mA@24V								

◇=option



**Note: for power supply type PX: please read Terminal 07-08 !**

Note !

**Terminal 05-06; transistor or relay output R1:**

This output is a pulse output. With SETUP A, the function of this output is set. The maximum pulse frequency of this output is 60Hz.

If a relay output option has been supplied, be sure that the output frequency does not exceed 5Hz or else the life-time of the relay will be reduced significantly.

**Terminal 03-04; negative total - transistor or relay output R2:**

This output is switched in case the calculated accumulated total counts down. This is the case as soon as the measured flow B is more as flow A.

**Type OA:**

An active 24V DC signal output is available with this option.

Max. driving capacity 50mA@24V per output. (Requires power supply type PD / PF / PM).

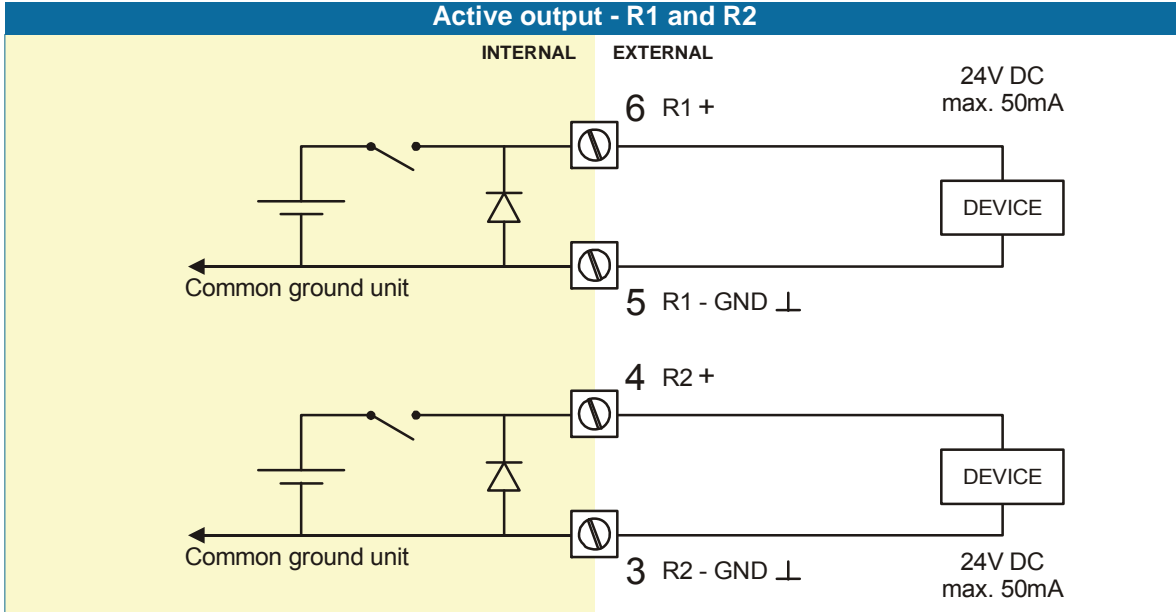

**Type OR:**

A mechanical relay output is available with this option.

Max. switch power 240V 0,5A per output. (Requires power supply type PF / PM).

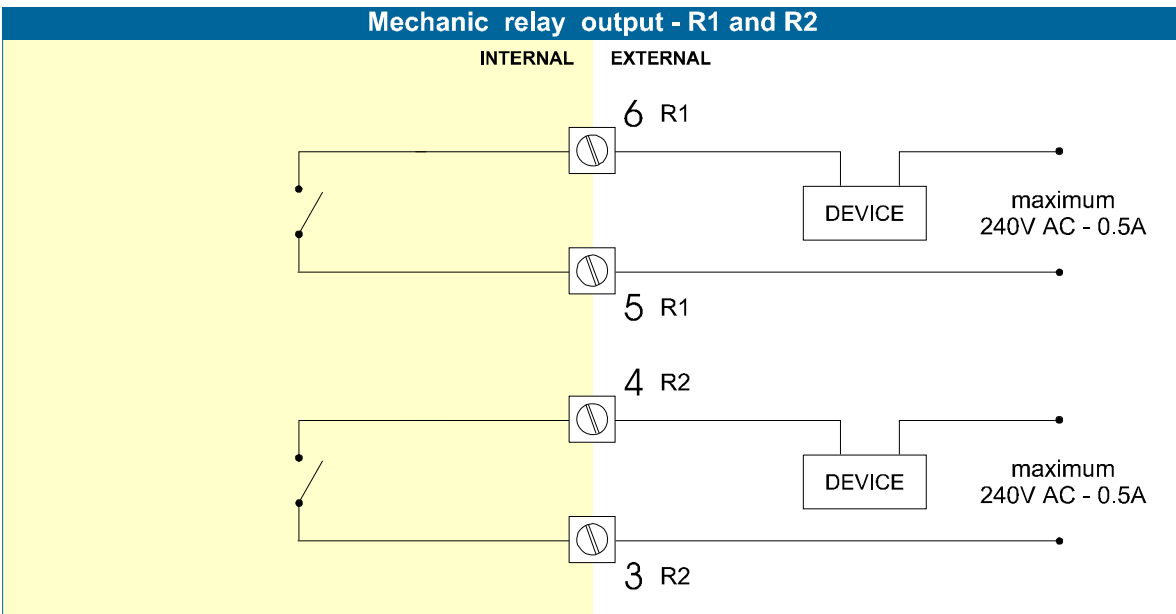

**Type OT:**

A passive transistor output is available with this option. Max. driving capacity 300mA@50V DC.

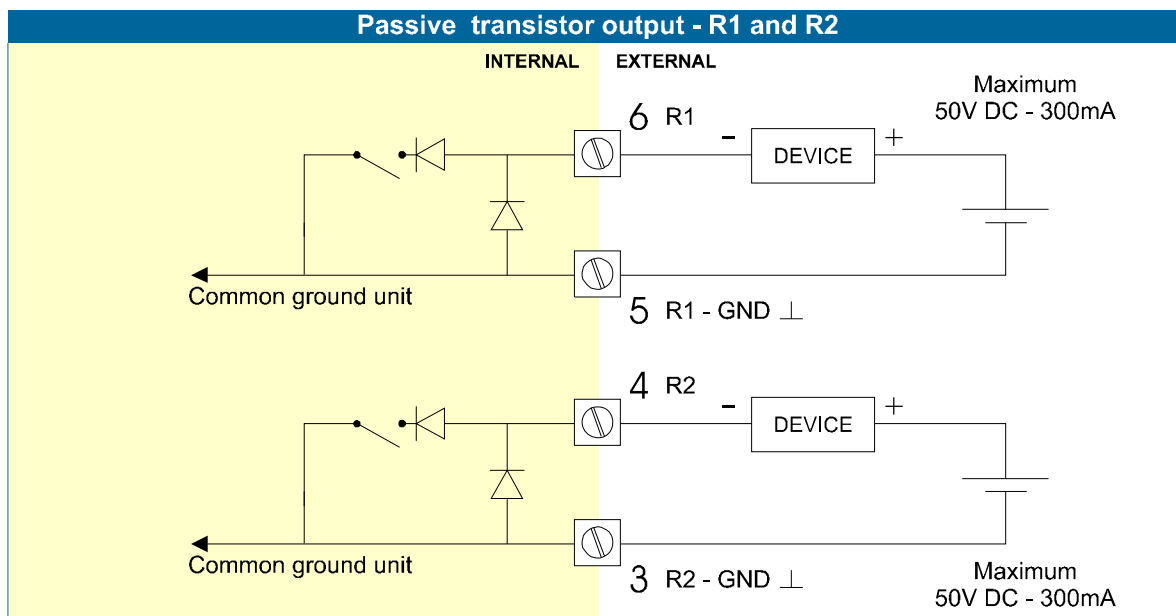

**Terminal 07-08; basic POWER SUPPLY - type PX - output loop powered:**

Connect an external power supply of 8-30VDC to these terminals or a 4-20mA loop.

Do not connect the "-" to terminal 7 and the "+" to terminal 8. When power is applied to these terminals, the (optional) internal battery will be disabled / enabled automatically to extend the battery life time.



Caution ! Only valid for standard passive output type AP!

**Terminal 07-08 analog output (SETUP 7) :**

An analog output signal proportional to the calculated differential / sum flowrate is available as standard.

**Type AA:**

An active 4-20mA signal proportional to the calculated differential / sum flowrate is available with this option. When the output is disabled, a 3.5mA signal will be generated on these terminals.

Max. driving capacity 1000 Ohm @ 24VDC. (Requires power supply type PD / PF / PM).

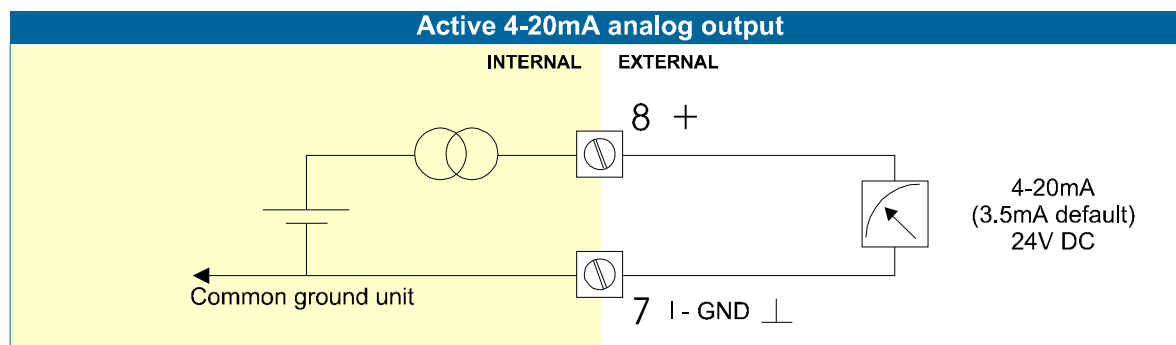

**Type AB:**

An active 0-20mA signal proportional to the calculated differential / sum flowrate is available with this option. Max. driving capacity 1000 Ohm @ 24VDC. (Requires power supply type PD / PF / PM).

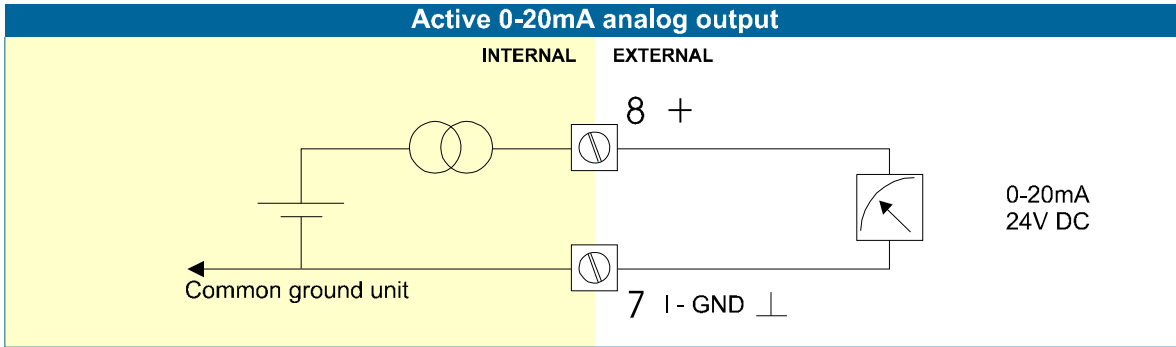

**Type AF:**

For the Intrinsically Safe floating 4-20mA signal: please read Chapter 5.

**Type AI:**

An isolated 4-20mA signal proportional to the calculated differential / sum flowrate is available with this option. When the output is disabled, a 3.5mA signal will be generated on these terminals. Max. driving capacity 1000 Ohm @ 30VDC. This option can be used with a battery powered unit but the life time of the battery is about 2 -3 years.

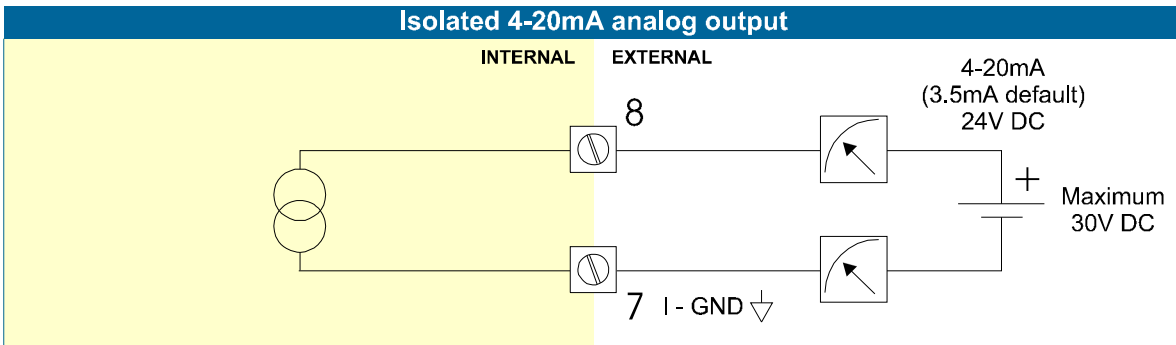

**Type AP:**

A passive 4-20mA signal proportional to the calculated differential / sum flowrate is available with this option. When a power supply is connected but the output is disabled, a 3.5mA signal will be generated. Max. driving capacity 1000 Ohm. This output does loop power the unit as well (type PX).

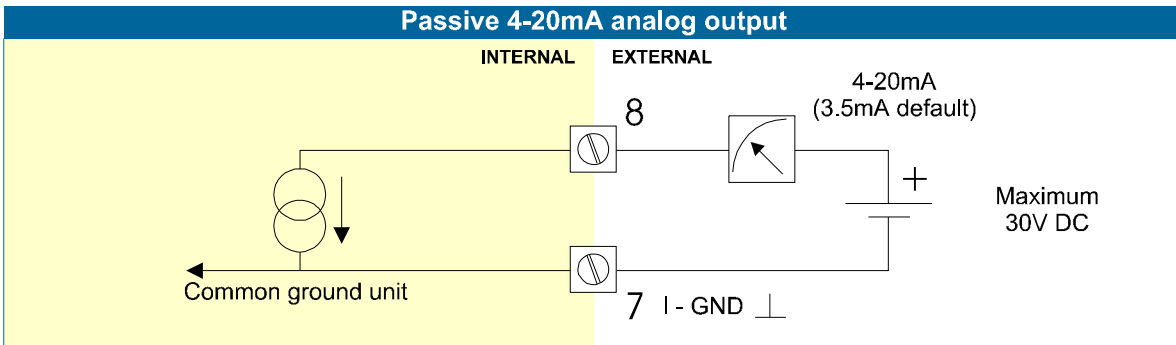

**Type AU:**

A 0-10VDC signal proportional to the calculated differential / sum flowrate is available with this option. Max. load 10mA @ 10VDC. (Requires power supply type PD / PF / PM).

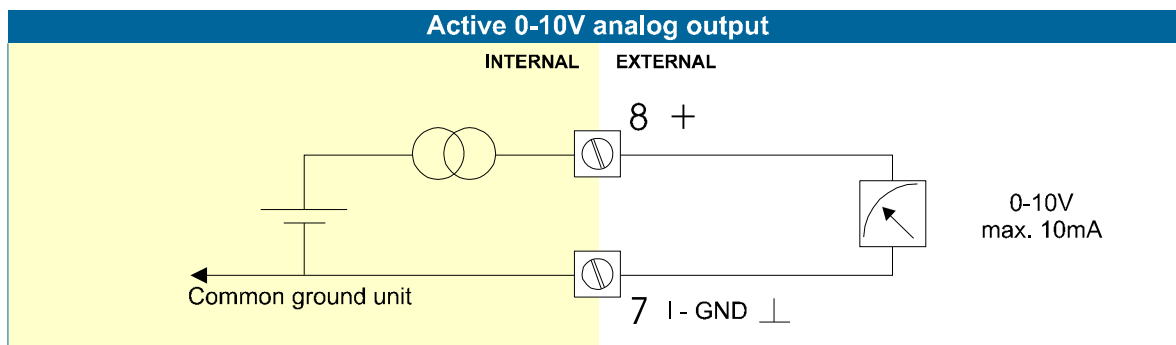
**Terminal 09-11; Flowmeter input:**

Three basic types of flowmeter signals can be connected to the unit: pulse, active pulse or sine-wave (coil). The screen of the signal wire must be connected to the common ground terminal 09 (unless earthed at the sensor itself).

The maximum input frequency is approximately 10 kHz (depending on the type of signal). The input signal type has to be selected with the correct SETUP-function (read par. 3.2.3.)

**Sine-wave signal (Coil):**

The F116-P is suitable for use with flowmeters which have a coil output signal. Two sensitivity levels can be selected with the SETUP-function:

COIL LO: sensitivity from about 120mVp-p.

COIL HI: sensitivity from about 20mVp-p.

Type ZF offers for setting COIL HI : sensitivity from about 10mVp-p.

Type ZG offers for setting COIL HI : sensitivity from about 5mVp-p.

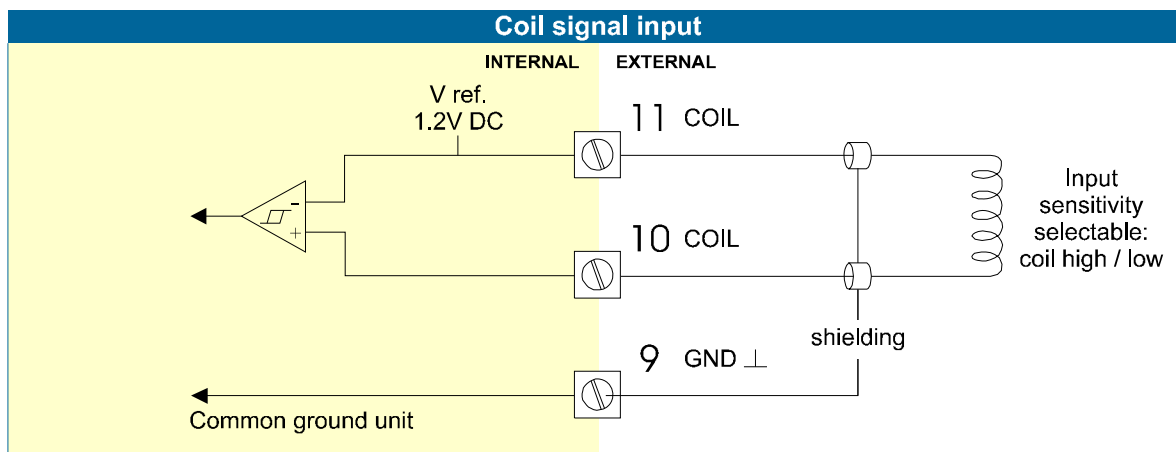

**Pulse-signal NPN / NPN-LP:**

The F116-P is suitable for use with flowmeters which have a NPN output signal. For reliable pulse detection, the pulse amplitude has to go below 1.2V. Signal setting NPN-LP employs a low-pass signal noise filter, which limits the maximum input frequency - read par. 3.2.3.

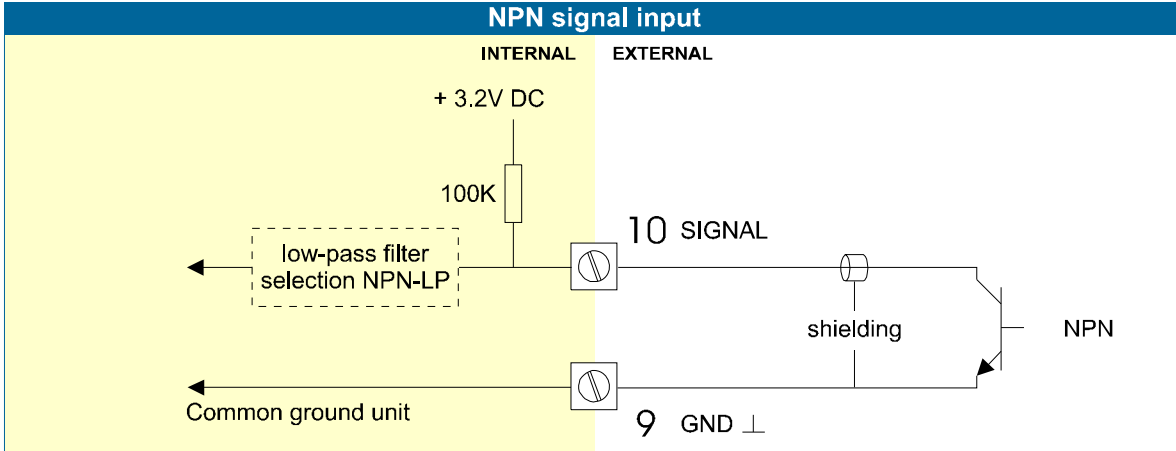

**Pulse-signal PNP / PNP-LP:**

The F116-P is suitable for use with flowmeters which have a PNP output signal. 3.2V is offered on terminal 11 which has to be switched by the sensor to terminal 10 (SIGNAL). For a reliable pulse detection, the pulse amplitude has to go above 1.2V. Signal setting PNP-LP employs a low-pass signal noise filter, which limits the maximum input frequency - read par. 3.2.3.

A sensor supply voltage of 8.1, 12 or 24V DC can be provided with power supply type PD, PF, PM. For a signal detection level of 50% of the supply voltage: please refer to "active signals".

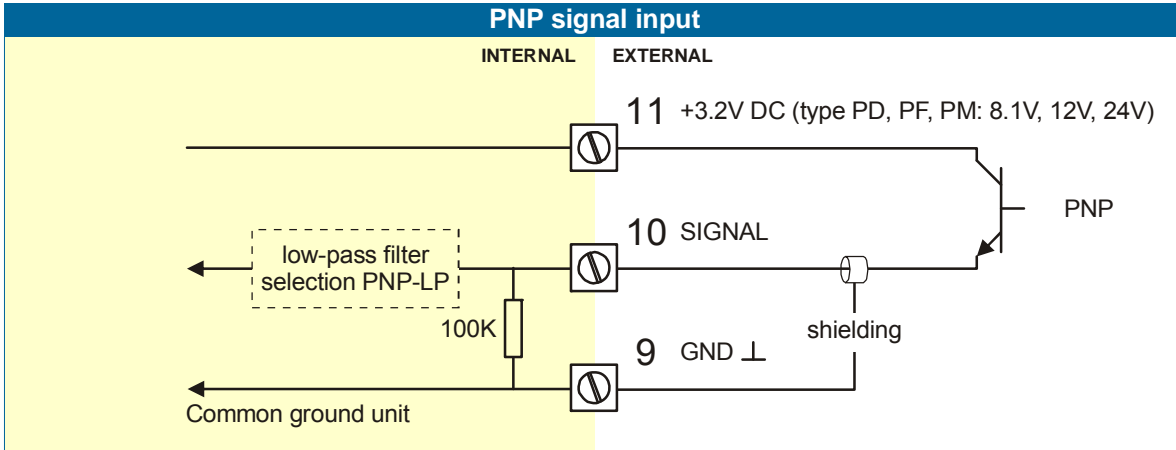



**Active signals 8.1V - 12V and 24V:**

If a sensor gives an active signal, please read par. 3.2.3. The detection levels are 50% of the selected supply voltage; approximately 4V (ACT\_8.1) or 6V (ACT\_12) or 12V (ACT\_24). Active signal selection may well be desired in the case of power supply type PD, PF, PM being supplied for sensor supply.

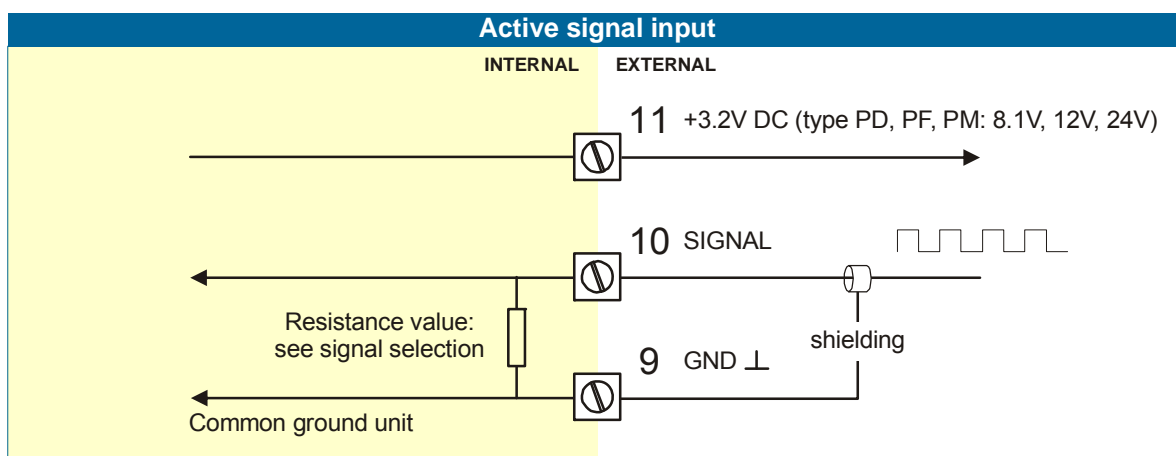
**Reed-switch:**

The F116-P is suitable for use with flowmeters which have a reed-switch. To avoid pulse bounce from the reed-switch, it is advised to select REED LP - low-pass filter (read par. 3.2.3.)

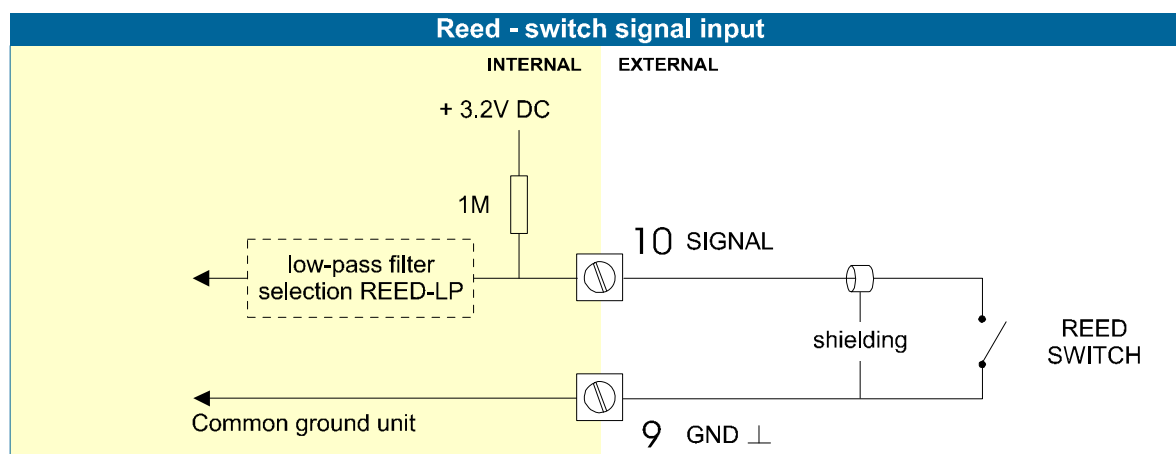
**NAMUR-signal:**

The F116-P is suitable for flowmeters with an Namur signal. The standard F116-P is not able to power the Namur sensor, as an external power supply for the sensor is required. However, a 8.2V sensor supply voltage (terminal 11) can be provided with power supply type PD, PF, PM.

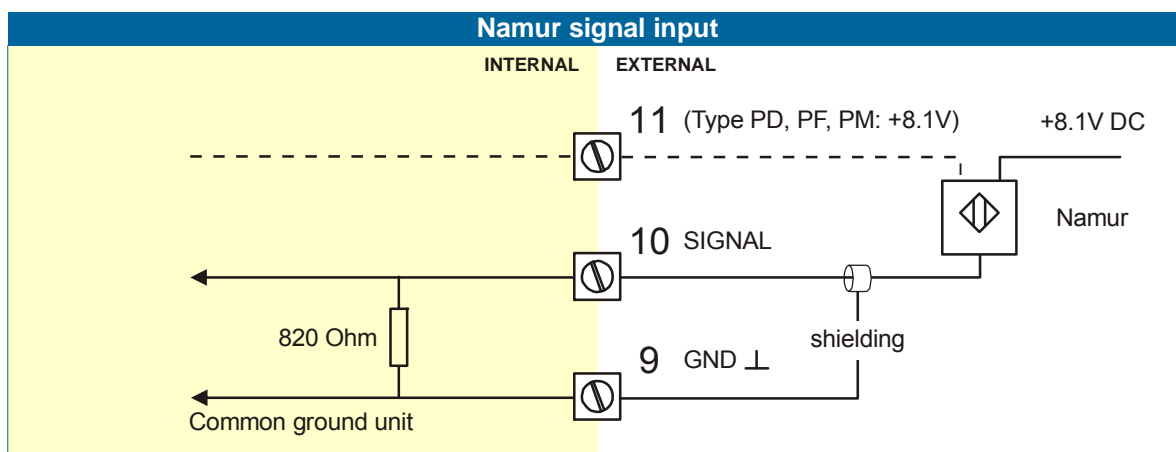

**Terminal 12-14; Flowmeter input B:**

Exactly as described for the flowmeter A, three basic types of flowmeter signals can be connected for flowmeter input B. Please refer to the descriptions per flowmeter type as describer for flowmeter A. The 9-10-11 do correspond with the terminals 12-13-14.

**Terminal 26-31: type CB / CH / CI / CT - communication RS232 / RS485 / TTL (option)**

- Full serial communications and computer control in accordance with RS232 (length of cable max. 15 meters) or RS485 (length of cable max. 1200 meters) is possible.
- Read the Modbus communication protocol and Appendix C.

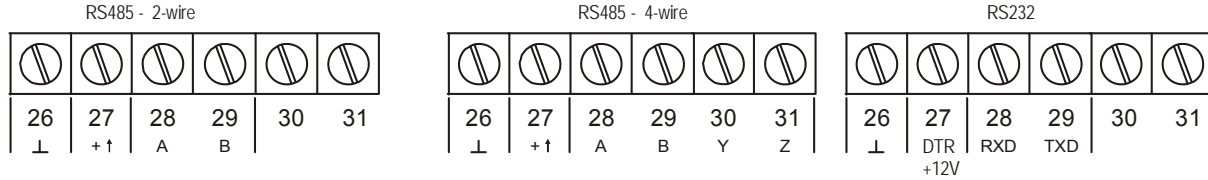

Fig. 10: Overview terminal connectors communication option.

When using the RS232 communication option, terminal 27 is used for supplying the interface. Please connect the DTR (or the RTS) signal of the interface to this terminal and set it active (+12V). If no active signal is available it is possible to connect a separate supply between terminals 26 and 27 with a voltage between 8V and 24V.

**Terminal 26-31: backlight - type ZB (option):**



**Note: if the unit is supplied with a power supply type PD, PF or PM, the backlight supply is integrated, so the text following is not applicable.**

To power the backlight, provide a 12-24V DC to terminal 26 (-) and 27 (+). An external trimmer 1kOhm trimmer can be used to tune the brightness of the backlight, or if not desired, a short-cut between these terminals have to be made which will result in the maximum brightness.



**Note: Intrinsically Safe as well as 4-wire RS485 communication is not possible in combination with type ZB, except if a PD, PF or PM power supply is being used.**

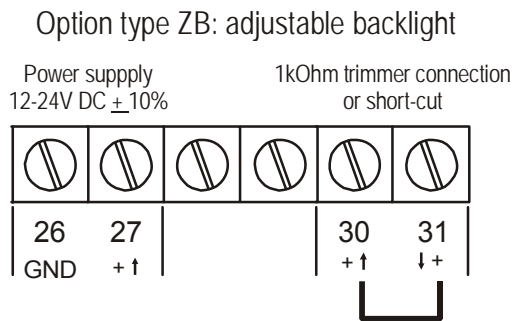

Fig. 11: Overview terminal connectors backlight option.

## 5. INTRINSICALLY SAFE APPLICATIONS

### 5.1. GENERAL INFORMATION AND INSTRUCTIONS



Caution !

#### Cautions

- Mounting, electrical installation, start-up and maintenance of this device may only be carried out by trained personnel authorized by the operator of the facility. Personnel must read and understand this Operating Manual before carrying out its instructions.
- This device may only be operated by personnel who are authorized and trained by the operator of the facility. All instructions in this manual are to be observed.
- Ensure that the measuring system is correctly wired up according to the wiring diagrams. Protection against accidental contact is no longer assured when the housing cover is removed or the cabinet has been opened (danger of electric shock). The housing may only be opened by trained personnel.
- To maintain the degree of protection of at least IP65 in accordance with IEC 60529, certified cable entries in accordance with IEC 61241-0 must be used and correctly installed. Unused openings must be closed with suitable blanking elements.
- When the enclosure of the Indicator is made of aluminum alloy, when used in a potentially explosive atmosphere requiring apparatus of equipment protection level Ga and Da, the unit must be installed such that, even in the event of rare incidents, an ignition source due to impact or friction sparks between the enclosure and iron/steel is excluded.
- Take careful notice of the " Safety rules, instructions and precautionary measures " in the front of this manual.



#### Safety Instructions

- When two or more active intrinsically safe circuits are connected to the indicator, in order to prevent voltage and/or current addition, applicable to the external circuits, precautions must be taken to separate the intrinsically safe circuits in accordance with IEC 60079-11.
- For the combined connection of the different supply, input and output circuits, the instructions in this manual must be observed.
- From the safety point of view the circuits shall be considered to be connected to earth.
- For installation under ATEX directive: this intrinsically safe device must be installed in accordance with the ATEX directive 94/9/EC and the product certificate KEMA 03ATEX1074 X.
- For installation under IECEx scheme: this intrinsically safe device must be installed in accordance with the product certificate IECEx DEK 11.0042X.
- Exchange of Intrinsically Safe battery FWLiBAT-0xx with certificate number KEMA 03ATEX1071 U or IECEx KEM 08.0005U is allowed in Hazardous Area. See paragraph 5.4. for detailed battery replacement instructions.



Note !

#### Please Note

- Certificates, safety values and declaration of compliance can be found in the document named: "Fluidwell F1...-XI - Documentation for Intrinsic Safety".
- Special conditions for safe use mentioned in both the certificate and the installation instructions must be observed for the connection of power to both input and / or output circuits.
- When installing this device in hazardous areas, the wiring and installation must comply with the appropriate installation standards for your industry.
- Study the following pages with wiring diagrams per classification.

**Label information (inside and outside the enclosure)**

Indicated labels on the back cover (below) and on the inside cover (right) show the type labels for intrinsically safe certified units. For details on usage see the separate “Fluidwell F1...-IX Documentation for Intrinsic Safety”.

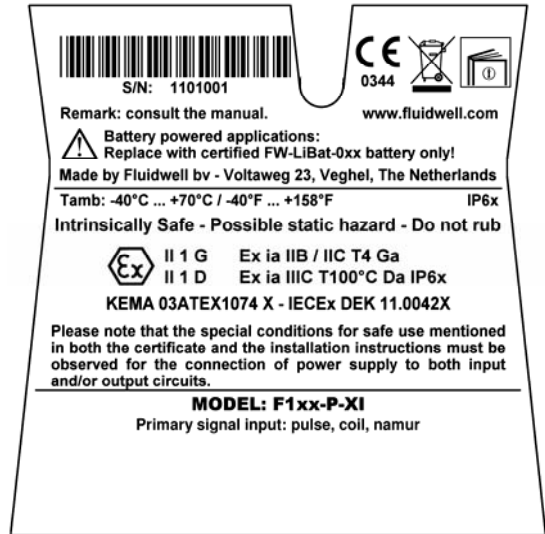
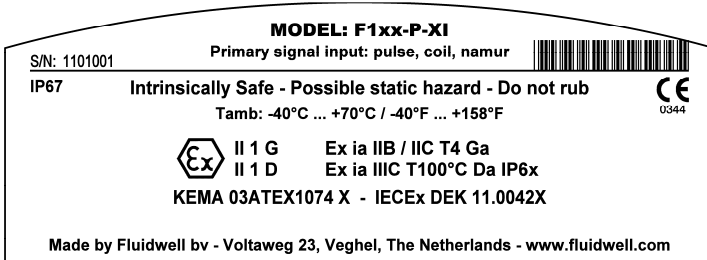

**Serial number and year of production**

This information can be looked-up on the display: See setup function (par. 3.2.2.) for details.

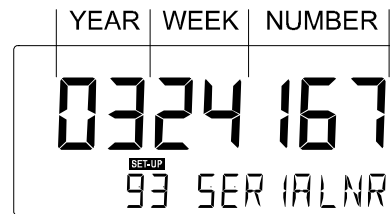

**5.2. TERMINAL CONNECTORS INTRINSICALLY SAFE APPLICATIONS**

*The unit is classified as group IIB/IIIC by default.*



Note !

Classification of the unit as group IIC is only possible under the following conditions:

- The indicator is either supplied by
  - the internal supply (option -PC); or
  - the external supply connected to terminals 0 and 1 (option -PD); or
  - the circuit supply connected to terminals 7 and 8 (option -AP);
 The maximum values for any of those circuits are those as defined for group IIB/IIIC;
- No other active external intrinsically safe circuits may be connected to the indicator, with exception of circuits connected to terminals 3 and 4 and/or terminals 5 and 6; the maximum values for any of those circuits are those as defined for group IIB/IIIC

**Terminal connectors F116-P-XI:**

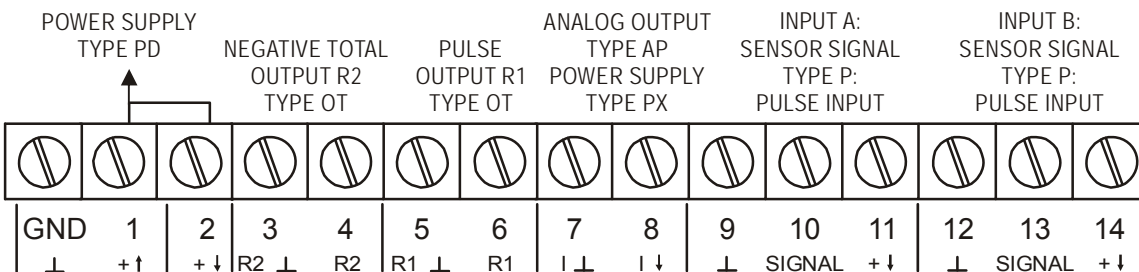

Fig. 12: Overview terminal connectors Intrinsically Safe.

**Explanation Intrinsically Safe options:**

**Type AF - Intrinsically Safe floating 4-20mA analog output - Terminal 7-8:**

A floating 4-20mA signal proportional to the calculated differential or sum flowrate is available with this option. When the output is disabled, a 3.5mA signal will be generated.  
 Max. driving capacity 1000 Ohm @ 30V DC.



*Note! It is required to link the minus from the analog output - terminal 7 - with a ground terminal of the unit; terminal: GND, 3, 5, 9, 12 or 15.*

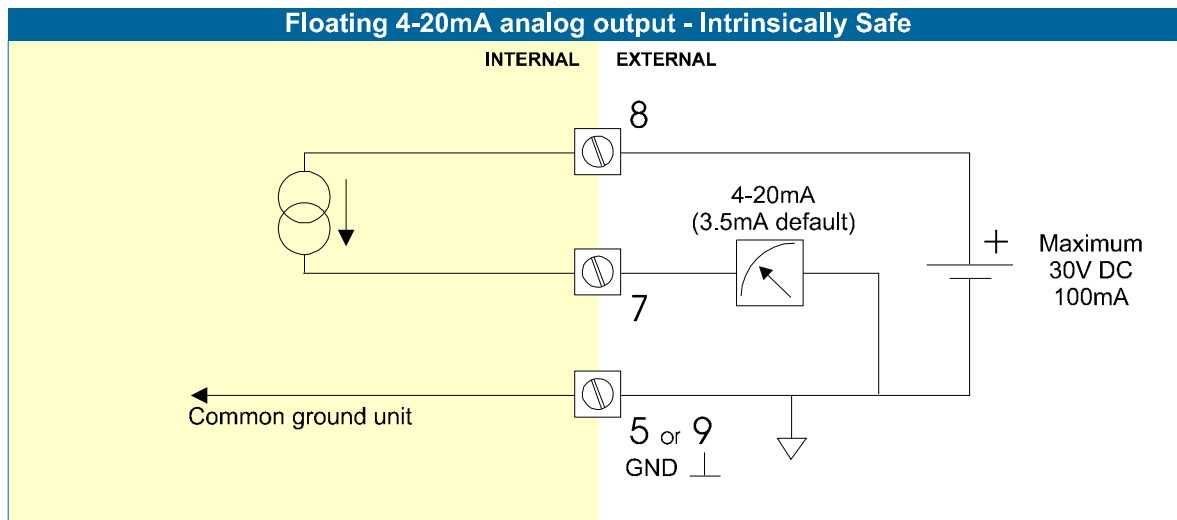

**Type PD - Intrinsically Safe power supply and sensor supply - Terminal GND- 01 and 11 + 14.**

TYPE	SENSOR SUPPLY	Terminal		
		GND	01	02
PD	Input voltage: 8-30V DC	L-	L+	internally linked with terminal 01.

Terminal 02: this terminal offers the same voltage as connected to terminal 01.

Terminal 11+14: these terminals offer a 3.2V or 8.1V to power the sensor.

This voltage is selected with the switch(es) inside the enclosure. First, remove the terminals after which the internal plastic cover can be removed.

Switch position terminal 11		Switch position terminal 14	
SWITCH 1	VOLTAGE	SWITCH 1	VOLTAGE
on	8.1 V DC	on	8.1 V DC
off	3.2 V DC	off	3.2 V DC

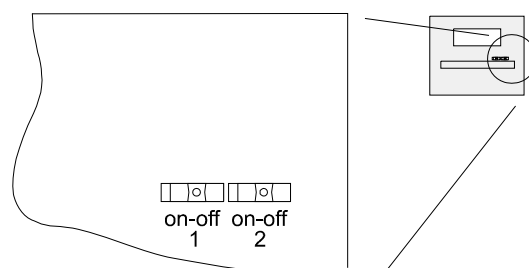

Fig. 13: Switch position voltage selection type PD-XI.

5.3 CONFIGURATION EXAMPLES

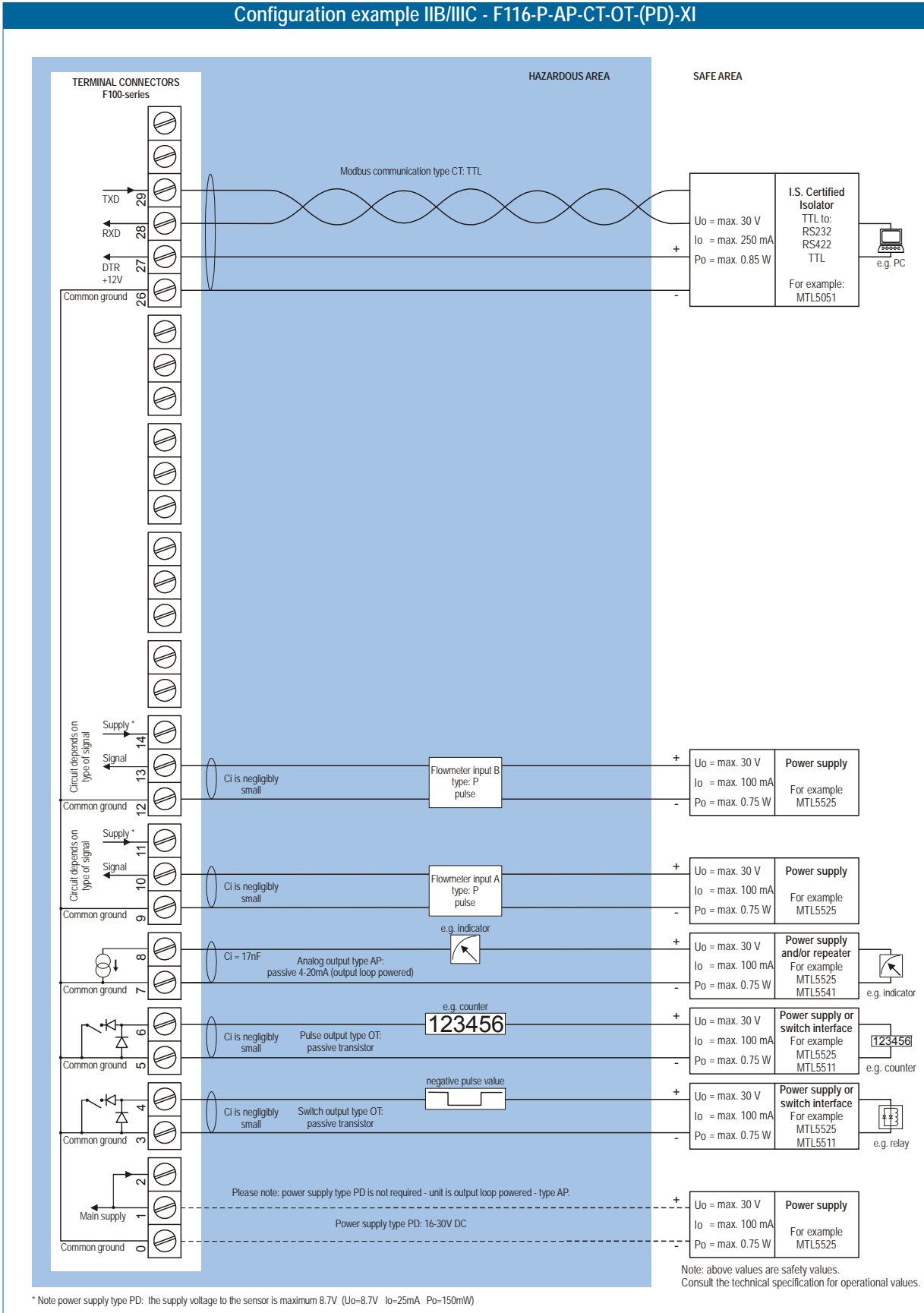

Fig. 14: Configuration example 1 Intrinsically Safe

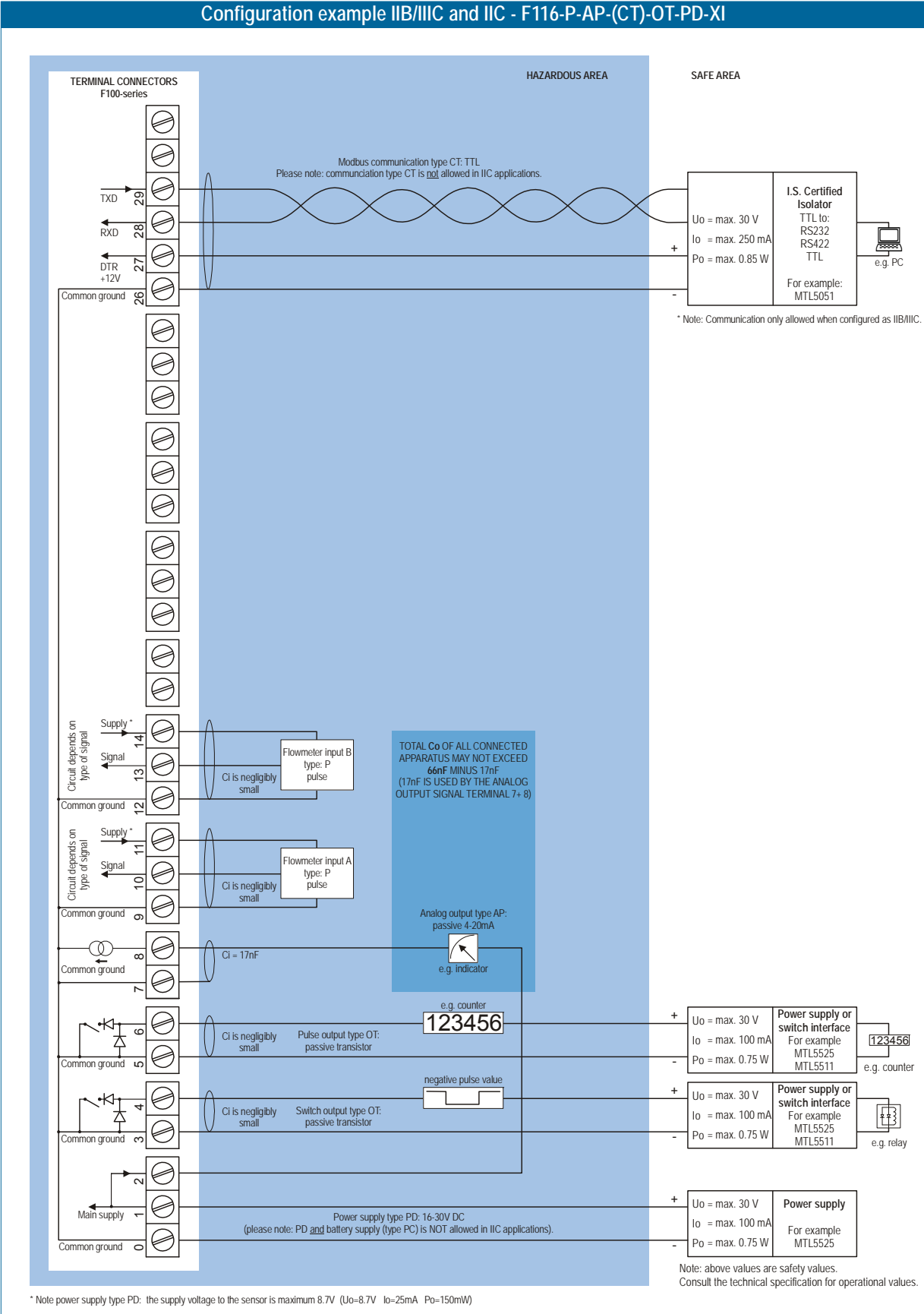

Fig. 15: Configuration example 2 Intrinsically Safe

## 5.4 BATTERY REPLACEMENT INSTRUCTIONS



### Safety Instructions

- **Fire, explosion or severe burns may result if mistreated.** Do not recharge, crush, disassemble, incinerate, heat above 100°C (212°F) or expose contents to water.
- Mounting, electrical installation, start-up and maintenance of this device may only be carried out by trained personnel authorized by the plant operator. Personnel must read and understand this instruction before carrying out the replacement procedure.
- Always follow the instructions listed in the supplied Battery Replacement Instruction Sheet.
- Batteries pose an environmental hazard. Return used batteries to a recycling point.





### Safety instructions for hazardous areas

- Verify the correct battery is supplied: **Only batteries with indicated Ex label are certified for replacement and use in hazardous areas.** Batteries for use in safe areas have no Ex label. **DO NOT EXCHANGE:** Using the wrong type of battery can pose a SERIOUS RISK.
- **For use in hazardous areas Fluidwell recommends FW-LiBAT batteries (manufactured by Fluidwell bv) only.**

### Battery replacement procedure

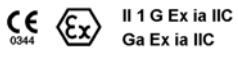

Depending on the production batch, one of two visualized Intrinsically Safe certified battery types may have been installed in the unit. They are interchangeable.

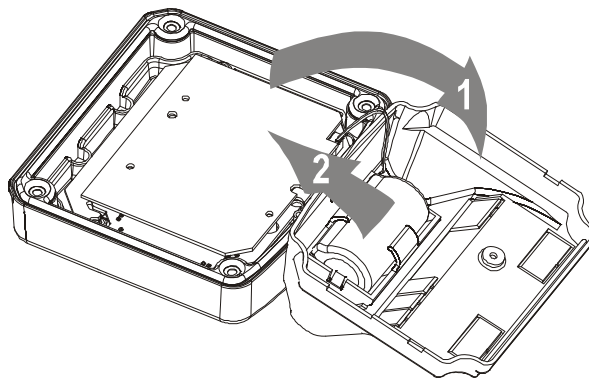
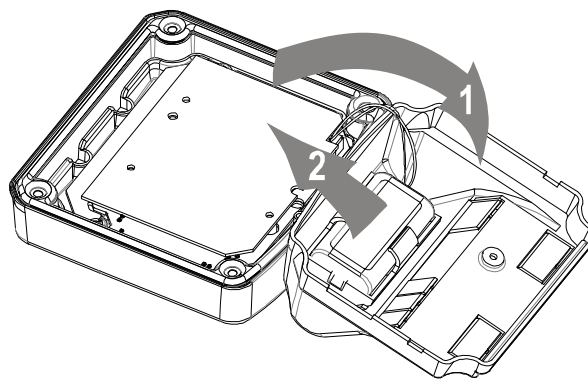
FW-LiBAT-001 battery	FW-LiBAT-021 battery
 <p>CE 0344 Ex II 1 G Ex ia IIC Ga Ex ia IIC</p> <p>KEMA 03ATEX1071 U IECEX KEM 08.0005U</p> <p>Fluidwell bv Intrinsically Safe Battery Part. no.: FW-LiBAT-001</p> <p>Uo = 3.9V Co = 100µF Io = 35mA Lo = 25mH Po = 35mW Ta = -40°C...+70°C</p> <p>Consult the manual for replacement instructions.</p> <p>WARNING: Fire, explosion or severe burns may result if mistreated. Do not recharge, crush, disassemble, incinerate, heat above 100°C (212°F) or expose contents to water.</p> <p>Primary Lithium Battery Only replace with Fluidwell I.S. battery pack!</p>	 <p>CE 0344 Ex II 1 G Ex ia IIC Ga</p> <p>KEMA 03ATEX1071 U IECEX KEM 08.0005U</p> <p>Fluidwell bv Intrinsically Safe Battery Part. no.: FW-LiBAT-021</p> <p>Uo = 3.9V Co = 100µF Io = 35mA Lo = 25mH Po = 35mW Ta = -40°C...+70°C</p> <p>Consult the manual for replacement instructions.</p> <p>WARNING: Fire, explosion or severe burns may result if mistreated. Do not recharge, crush, disassemble, incinerate, heat above 100°C (212°F) or expose contents to water.</p> <p>Primary Lithium Battery Only replace with Fluidwell I.S. battery pack!</p>
	

1. To replace the battery, open the unit to gain access to the back inside cover of the unit.
2. Unplug the field connectors from the back inside of the unit.
3. Remove the screw that holds the plastic inside cover.
4. Open the cover and unplug the battery connector.
5. Remove the battery from the inside of the plastic cover. *Do not remove the battery clip!*
6. Install the new battery and re-assemble the unit in reverse order.
7. Start-up the unit



## 6. MAINTENANCE

### 6.1. GENERAL DIRECTIONS



- *Mounting, electrical installation, start-up and maintenance of the instrument may only be carried out by trained personnel authorized by the operator of the facility. Personnel must read and understand this Operating Manual before carrying out its instructions.*
- *The F116-P may only be operated by personnel who are authorized and trained by the operator of the facility. All instructions in this manual are to be observed.*
- *Ensure that the measuring system is correctly wired up according to the wiring diagrams. Protection against accidental contact is no longer assured when the housing cover is removed or the panel cabinet has been opened (danger from electrical shock). The housing may only be opened by trained personnel.*
- *Take careful notice of the " Safety rules, instructions and precautionary measures " in the front of this manual.*

The F116-P does not require special maintenance unless it is used in low-temperature applications or surroundings with high humidity (above 90% annual mean). It is the users responsibility to take all precautions to dehumidify the internal atmosphere of the F116-P in such a way that no condensation will occur, for example by placing dry silica-gel sachet in the casing just before closing it. Furthermore, it is required to replace or dry the silica gel periodically as advised by the silica gel supplier.

#### **Battery life-time:**

It is influenced by several issues :

- Type of sensor: read chapter 3.2.3. NPN and PNP inputs consume more energy than coil inputs.
- Input frequency: the higher the frequency, the shorter the battery life-time.
- Flowrate calculation: the lower number of pulses (SETUP 26) the shorter the battery life-time.
- Analog output signal; be sure that an external power supply is connected or that the function is disabled if not in use; or else it will have a major influence on the battery life-time (SETUP 81).
- Display update: fast display update uses significantly more power; SETUP 61.
- Pulse output and communications .
- Low temperatures; the available power will be less due to battery chemistry.



**Note:** *It is strongly advised to disable unused functions.*

#### **Check periodically:**

- The condition of the casing, cable glands and front panel.
- The input/output wiring for reliability and aging symptoms.
- The process accuracy. As a result of wear and tear, re-calibration of the flowmeter might be necessary. Do not forget to re-enter any subsequent K-factor alterations.
- The indication for low-battery.
- Clean the casing with soapy-water. Do not use any aggressive solvents as these might damage the coating.

### 6.2. REPAIR

This product cannot be repaired by the user and must be replaced with an equivalent certified product. Repairs should only be carried out by the manufacturer or his authorized agent.

## APPENDIX A: TECHNICAL SPECIFICATION

### GENERAL

Display	
Type	High intensity reflective numeric and alphanumeric LCD, UV-resistant.
Digits	Seven 17mm (0.67") and eleven 8mm (0.31"). Various symbols and measuring units.
Refresh rate	User definable: 8 times/sec - 30 secs.
Type ZB	Transflective LCD with green LED backlight. Good readings in full sunlight and darkness. Note: only available for safe area applications. Power requirements: 12-24V DC + 10% or type PD, PF, PM. Power consumption max. 1 Watt.

Enclosures	
General	Die-cast aluminum or GRP (Glassfibre Reinforced Polyamide) enclosure with Polycarbonate window, silicone and EPDM gaskets. UV stabilized and flame retardant material.
Control Keys	Three industrial micro-switch keys. UV-stabilized silicone keypad.
Painting	Aluminum enclosure only: UV-resistant 2-component industrial painting.
Panel-mount enclosures	Dimensions: 130 x 120 x 60mm (5.10" x 4.72" x 2.38") – LxHxD.
Classification	IP65 / NEMA4X
Panel cut-out	115 x 98mm (4.53" x 3.86") LxH.
Type HC	GRP panel-mount enclosure
Type HB	Aluminum panel-mount enclosure
Field/wall-mount enclosures	Dimensions: 130 x 120 x 75mm (5.10" x 4.72" x 2.95") – LxHxD.
Classification	IP67 / NEMA4X
Aluminum enclosures	
Type HA	Drilling: 2x PG9 – 1x M20.
Type HM	Drilling: 2x M16 – 1x M20.
Type HN	Drilling: 1x M20.
Type HO	Drilling: 2x M20.
Type HP	Drilling: 6x M12.
Type HT	Drilling: 1x ½"NPT.
Type HU	Drilling: 3x ½"NPT.
Type HZ	No drilling.
GRP enclosures	
Type HD	No drilling.
Type HE	Drilling: 2x 16mm (0.63") – 1x 20mm (0.78").
Type HF	Drilling: 1x 22mm (0.87").
Type HG	Drilling: 2x 20mm (0.78").
Type HH	Drilling: 6x 12mm (0.47").
Option ZS	Silicone free ABS enclosure with EPDM and PE gaskets. UV-resistant polyester keypad. Note: this option comes with type HD only.

Operating temperature	
Operational	-40°C to +80°C (-40°F to +176°F)
Intrinsically Safe	-40°C to +70°C (-40°F to +158°F)

Power supply	
Type PB	Lithium battery - life-time depends upon settings - up to 5 years.
Type PC	Intrinsically Safe lithium battery - life-time depends upon settings - up to 5 years.
Type PD	8-24V AC / DC ± 10%. Power consumption max. 10 Watt. Intrinsically safe: 16-30V DC; power consumption max. 0.75 Watt.
Type PF	24V AC / DC ± 10%. Power consumption max. 15 Watt.
Type PL	Input loop powered from sensor signal 4-20mA (type A, non IS).
Type PM	115-230V AC ± 10%. Power consumption max. 15 Watt.
Type PX	Output loop powered: 8-30V DC. Power consumption max. 0.5 Watt.
Note PF / PM	The total consumption of the sensors', backlight and outputs may not exceed 400mA@24V.
Note I.S. applications	For intrinsically safe applications, consult the safety values in the certificate.

Sensor excitation	
Type PB / PC / PX	3.2V DC for pulse signals and 1.2V DC for coil pick-up. Note: This is not a real sensor supply. Only suitable for pulse sensors with a very low power consumption like coils (sine wave) and reed-switches.
Type PD	1.2 / 3.2 / 8.2 / 12 and 24V DC - max. 50mA@24V DC
Type PD-XI	Intrinsically safe: Pulse signals: 1.2 / 3.2 / 8.2 - max. 7mA@8.2V DC. Analog signals: the sensor supply voltage is according to the power supply voltage connected to terminal 1. Also terminal 2 offers the same voltage.
Type PF / PM	1.2 / 3.2 / 8.2 / 12 and 24V DC - max. 400mA@24V DC.

Terminal connections	
Type:	Removable plug-in terminal strip. Wire max. 1.5mm <sup>2</sup> and 2.5mm <sup>2</sup> (Type PM / PF)

Data protection	
Type	EEPROM backup of all setting. Backup of running totals every minute. Data retention at least 10 years.
Pass code	Configuration settings can be pass code protected.

Hazardous area (option)	
Intrinsically safe Type XI	<b>ATEX approval:</b>  II 1 G Ex ia IIB/IIC T4 Ga II 1 D Ex ia IIIC T100°C Da IP6x  <b>IECEX approval:</b> Ex ia IIB/IIC T4 Ga Ex ia IIIC T100°C Da IP6x
Explosion proof Type XD/XF	ATEX approval ref.: <EX> II 2 GD EEx d IIB T5. Weight appr. 15kg. Dimensions of enclosure: 350 x 250 x 200mm (13.7" x 9.9" x 7.9") LxHxD.

Directives & Standards	
EMC	Directive 2004/108/EC, FCC 47 CFR part 15
Low voltage	Directive 2006/95/EC
ATEX / IECEX	Directive 94/9/EC, IEC 60079-0, IEC 60079-11, IEC 60079-26
IP & NEMA	EN 60529 & NEMA 250

## INPUTS

Flowmeter	
Type P	Coil/sine wave (minimum 20mVp-p or 80mVp-p - sensitivity selectable), NPN/PNP, open collector, reed-switch, Namur, active pulse signals 8 - 12 and 24V.
Frequency	Minimum 0 Hz - maximum 7 kHz for total and flowrate. Maximum frequency depends on signal type and internal low-pass filter. E.g. Reed switch with low-pass filter: max. frequency 120 Hz.
K-Factor	0.000010 - 9,999,999 with variable decimal position.
Low-pass filter	Available for all pulse signals.
Type A	(0)4-20mA - with signal calibration feature at any current within the range.
Type U	0-10 V - with signal calibration feature at any voltage within the range.
Accuracy	Resolution: 14 bit.. Error < 0.025mA / ±0.125% FS. Low level cut-off programmable.
Span	0.000010 - 9,999,999 with variable decimal position.
Update time	Four times a second.
Voltage drop	2.5 Volt.
Load impedance	3kOhm
Relationship	Linear and square root calculation.
Note	For signal type A and U: external power to sensor is required; e.g. Type PD.

## OUTPUTS

Analog output	
Function	Transmitting calculated differential or sum flowrate.
Accuracy	10 bit. Error < 0.05% - update 10 times a second. Software function to calibrate the 4.00mA and 20.00mA levels precisely within set-up.
Load	max. 1 kOhm
Type AA	Active 4-20mA output (requires type OA + PD, PF or PM).
Type AB	Active 0-20mA output (requires type OA + PD, PF or PM).
Type AF	Passive floating 4-20mA output for Intrinsically Safe applications (requires PC, PD or PL).
Type AI	Passive galvanically isolated output (requires PB, PD, PF, PL or PM).
Type AP	Passive 4-20mA output - output loop powered (type PX).
Type AU	Active 0-10V output (requires type OA + PD, PF or PM).

Transistor output(s)	
Pulse output	Max. frequency 60Hz. Pulse length user definable between 7,8msec up to 2 seconds.
Function	Two outputs: scaled pulse output transmitting accumulated total and flow direction indication.
Type OA	Active 24V DC transistor output; max. 50mA per output (requires type AA + PD, PF or PM).
Type OR	Isolated mechanic relay output; max. switch power 230V AC - 0,5A (requires type PF or PM).
Type OT	Passive transistor output - not isolated. Load max. 50V DC - 300mA.

Communication option	
Functions	reading display information, reading / writing all settings.
Protocol	Modbus RTU
Speed	1200 - 2400 - 4800 - 9600 baud
Addressing	maximum 255 addresses.
Type CB	RS232
Type CH	RS485 2-wire
Type CI	RS485 4-wire
Type CT	TTL Intrinsically Safe communication.
Type CX	no communication.

## OPERATIONAL

<b>Operator functions</b>	
Displayed functions	<ul style="list-style-type: none"> <li>• calculated differential or sum total and/or flowrate.</li> <li>• calculated differential or sum accumulated total.</li> <li>• flowrate A</li> <li>• total A</li> <li>• flowrate B</li> <li>• total B</li> <li>• all totals can be reset to zero by pressing the CLEAR-key twice.</li> </ul>

<b>Total</b>	
Digits	7 digits.
Units	L, m3, GAL, USGAL, KG, lb, bbl, no unit.
Decimals	0 - 1 - 2 or 3.
Note	total can be reset to zero.

<b>Accumulated total</b>	
Digits	11 digits.
Units / decimals	according to selection for total.

<b>Flowrate</b>	
Digits	7 digits.
Units	mL, L, m3, mg, g, kg, ton, GAL, bbl, lb, cf, rev, no unit
Decimals	0 - 1 - 2 or 3.
Time units	/sec - /min - /hr - /day.

## APPENDIX B: PROBLEM SOLVING

In this appendix, several problems are included that can occur when the F116-P is going to be installed or while it is in operation.

### Flowmeter does not generate pulses:

Check:

- Signal selection SETUP - 71 / 72,
- Pulse amplitude (par. 4.4.3.),
- Flowmeter, wiring and connection of terminal connectors (par. 4.4.3.),
- Power supply of flowmeter (par. 4.4.2.).

### Flowmeter generates "too many pulses":

Check:

- Settings for total and Flowrate: SETUP 11-14, 21-27, 31-32 and 41-42.
- Type of signal selected with actual signal generated - SETUP - 71 / 72,
- Sensitivity of coil input - SETUP - 71 / 72 and par. 4.4.3.
- Proper grounding of the F116-P - par. 4.4.1.
- Use screened wire for flowmeter signals and connect screen to terminal 9 or 12. (unless connected at sensor)

### Analog output does not function properly:

Check:

- SETUP 81 - is the function enabled?
- SETUP 82 / 83: are the flow-levels programmed correctly?
- connection of the external power-supply according to the specification.

### Pulse output does not function:

Check:

- SETUP 91 - pulse per "x" quantity; is the value programmed reasonable and will the maximum output be under 60Hz?
- SETUP 92 - impulse width; is the external device able to recognize the selected pulse width and frequency?

### Flowrate displays "0 / zero" while there is flow (total is counting):

Check:

- SETUP 22 / 25 and 41 / 42: are the K-factor and time unit correct?
- SETUP 26 / 27: The unit has to count the number of pulses according to SETUP 26 within the time according to SETUP 27. Make sure that 27 is set to 10.0 seconds for example : the result is that the unit has at least 10 seconds time to measure the number of pulses according to SETUP 26.

### The pass code is unknown:

If the pass code is not 1234, there is only one possibility left: call your supplier.

### ALARM

When the alarm flag starts to blink an internal alarm condition has occurred. Press the "select button" several times to display the 5-digit error code. The codes are:

- 0001: irrecoverable display-data error: data on the display might be corrupted.
- 0002: irrecoverable data-storage error: the programming cycle might have gone wrong: check programmed values.
- 0003: error 1 and error 2 occurred simultaneously

If the alarm occurs more often or stays active for a longer time, please contact your supplier.

## APPENDIX C: COMMUNICATION VARIABLES

### Remarks:

- Below, an overview of the F116-P specific variables; other common variables are described in the standard table.
- All numbers are decimal numbers, unless otherwise noted.
- The following variables of the standard table (var00-var30) are not valid for this product and will be responded with value 1: var00, 03-05, 07,08, 16-22, 24, 26-29.

CONFIGURATION VARIABLES F116-P - SETUP-LEVEL:				
VAR	DESCRIPTION	BYTES	VALUE	REMARKS
<b>TOTAL A</b>				
32 (20h)	unit	1	0=L 1=m3 2=kg 3=lb 4=gal 5=usgal 6=bbl 7=none	
33 (21h)	decimals	1	0...3	
34 (22h)	K-factor	3	1....9.999.999	K-f 0000001 - K-f 0000009 is allowed when decs < 6! (VAR37)
37 (25h)	decimals K-factor	1	0...6	
<b>FLOWRATE A</b>				
48 (30h)	unit	1	0=mL 1=L 2=m3 3=mg 4=g 5=kg 6=ton 7=gal 8=bbl 9=lb 10=cf 11=rev (revolutions for RPM) 12=none	
49 (31h)	time unit	1	0=sec 1=min 2=hour 3=day	
50 (32h)	decimals	1	0...1	
51 (33h)	K-factor	3	1....9.999.999	K-f 0000001 - K-f 0000009 is allowed when decs < 6! (VAR54)
54 (36h)	decimals K-factor	1	0...6	
55 (37h)	number of pulses	1	1..255	
56 (38h)	cut-off time	2	1 .. 9999	steps of 100ms

VAR	DESCRIPTION	BYTES	VALUE	REMARKS
<b>TOTAL B</b>				
40 (28h)	K-factor	3	1....9.999.999	K-f 0000001 - K-f 0000009 is allowed when decs < 6! (VAR43)
43 (2Bh)	decimals K-factor	1	0...6	
<b>FLOWRATE B</b>				
227 (E3h)	K-factor	3	1....9.999.999	K-f 0000001 - K-f 0000009 is allowed when decs < 6! (VAR230)
230 (E6h)	decimals K-factor	1	0...6	
231 (E7h)	number of pulses	1	1..255	
232 (E8h)	cut-off time	2	1 .. 9999	steps of 100ms
<b>DISPLAY</b>				
64 (40h)	display function	1	0=total 1=flowrate 2=all	
68 (44h)	set flowrate monitor	1	0=operator level 1=SETUP level	
<b>POWERMANAGEMENT</b>				
80 (50h)	LCD update time	1	0=fast 1=1sec 2=3sec 3=15sec 4=30sec 5=off	
81 (51h)	power-mode battery	1	0=operational 1=shelf	
<b>FLOWMETER</b>				
96 (60h)	flowmeter signal A	1	0=npn 1=npn-lp 2=reed 3=reed LP 4=PNP 5=PNP-lp 6=namur 7=coil hi 8=coil lo	
97 (61h)	flowmeter signal B	1	0=npn 1=npn-lp 2=reed 3=reed LP 4=PNP 5=PNP-lp 6=namur 7=coil hi 8=coil lo	



VAR	DESCRIPTION	BYTES	VALUE	REMARKS
<b>ANALOG OUTPUT</b>				
112 (70h)	analog output	1	0=disable 1=enable	
116 (71h)	minimum rate	3	0..9999999	unit, time, decimals acc. var48-50
116 (74h)	maximum rate	3	0..9999999	unit, time, decimals acc. var48-50
119 (77h)	cut off percentage	1	0..99	steps of 0.1%
120 (78h)	tune minimum rate	2	0..9999	
122 (7Ah)	tune maximum rate	2	0..9999	
99 (63h)	filter	1	0....99	
<b>PULSE OUTPUT</b>				
128 (80h)	impulse width	1	0=off 1=short 2=long	
129 (81h)	pulse per X quantity	3	1..9999999	unit, decimals acc. var32 -33
<b>OTHERS</b>				
168 (A8h)	pass code	2	xxxx	read only!
170 AAh	tagnumber	3	0..9999999	Other vars: see standard table

## OTHER F116-P VARIABLES FOR COMMUNICATION

### Differential / sum TOTAL - variable number 1590 (636h) – 6 bytes

READ TOTAL: The value of total read using RS communications might differ from the value that appears on the display. This is due to the fact that the display can only display up to seven digits (e.g. when two decimals are selected for total and total has a value of 123456,78 the display will show 23456,78 while communication will read a “total” of 12345678 and a “total decimals” of 2).

WRITE TOTAL: Total can only be cleared. This means writing a value different from 0 will result in the reply of an error message. Only writing 6 bytes of zero's to total will be accepted.

### Differential / sum ACCUMULATED TOTAL - variable number 1584 (630h) – 6 bytes

#### Accumulated Total flow A - variable number 560 (230h) – 6 bytes

#### Accumulated Total flow B - variable number 1070 (430h) – 6 bytes

READ ACC. TOTAL: A difference between the read value and the display value, as explained for “Read total”, might appear here too.

WRITE ACC. TOTAL: not possible.

When reading or writing total or accumulated total it should be noted that the used values are given including the decimals. This means that a read/write to one of these variables should be accompanied with a read/write to the variable that holds the number of decimals for this variable:

#### **Example: read var. 1584 for differential total:**

*Read var. 33 for total decimals and calculate the real value of total by multiplying total with 10<sup>(total decimals)</sup>*

### Differential / sum FLOWRATE - variable number 63Ch – 4 bytes

READ FLOWRATE: The value difference as mentioned with total/acc. total might appear here too.

WRITE FLOWRATE: not possible.

#### FLOWRATE A - variable number 572 (23Ch) – 4 bytes

#### FLOWRATE B - variable number 588 (24Ch) – 4 bytes

Read flowrate: The value difference as mentioned with total/acc. total might appear here too.

Write flowrate: Impossible.

## INDEX OF THIS MANUAL

accumulated Total	8	IP classification	22
actual settings	52	keys	7
alarm	8	low-battery	8
analog		main-function	10
disable/enable	19	maintenance	41
floating output.	37	model	21
flowrate max.	19	NAMUR-signal	33
flowrate min.	19	negative total output	28
intrinsically safe output.	37	Notes	51
<i>output loop powered.</i>	29	Operator level	8
tune / calibrate	19	pass code	21, 45
Analog output	29	power supply	27, 29
Backlight	34	power supply intrinsically safe	37
battery life time	17, 41	Problem solving	45
Clear Total	8	pulse output	28
Coil-signal	31	pulse length / period time	20
communication	34	pulse per quantity	20
family-specific variables	46	Pulse-signal active pulse	33
Configuration	9	Pulse-signal NPN/PNP	32
Dimension enclosures	23, 24	rate/Total	8
display		Reed-switch:	33
function	16	serial number	21
display update	17	SETUP-level	9
flowmeter		subfunction	10
signal	18	tagnumber	21
Flowmeter input	31, 34	Technical specification	42
flowrate		terminal connectors	27
calculation	15	total	
decimals	14	decimals	13
decimals k-factor	14, 15	decimals k-factor	13, 15
measuring unit	14	k-factor	13, 14, 15
time unit	14	measuring unit	13, 14
Installation	22	version software	21
Intrinsic safety	35	Voltage selection sensor	26, 37
Intrinsically Safe options	37		

## LIST OF FIGURES IN THIS MANUAL

Fig. 1: Typical application for the F116-P. ....	5
Fig. 2: Control Panel. ....	7
Fig. 3: Example of display information during process. ....	8
Fig. 4: Example of low-battery alarm. ....	8
Fig. 5: Dimensions aluminum enclosures. ....	23
Fig. 6: Dimensions GRP enclosures. ....	24
Fig. 7: Grounding aluminum enclosure with type PM 115-230V AC. ....	25
Fig. 8: Switch setting sensor supply voltage. ....	26
Fig. 9: Overview of terminal connectors standard configuration F116-P and options. ....	27
Fig. 10: Overview terminal connectors communication option. ....	34
Fig. 11: Overview terminal connectors backlight option. ....	34
Fig. 12: Overview terminal connectors Intrinsically Safe. ....	36
Fig. 13: Switch position voltage selection type PD-XI. ....	37
Fig. 14: Configuration example 1 Intrinsically Safe. ....	38
Fig. 15: Configuration example 2 Intrinsically Safe. ....	39

## NOTES

# DECLARATION OF CONFORMITY



*Count on us.*

## Declaration of Conformity

### Fluidwell F1- series

Veghel, February 2015

We, Fluidwell BV, declare under our sole responsibility that the F1- series are designed and will operate conform the following applicable European Directives and Standards, when installed and operated according to the manual:

EMC Directive 2004/108/EC EN61000-6-2:2005, EN61000-6-3:2007  
EN61326-1:2006

RoHS Directive 2011/65/EU EN 50581:2012

ATEX Directive 94/9/EC EN60079-0:2009  
Models –XI, Intrinsically Safe: EN60079-11:2007  
EN60079-26:2007  
EN61241-11:2006

Protective system:  II 1 G Ex ia IIC T4 Ga  
II 1 D Ex ia IIIC T100 °C Da IP6X

Certificate: KEMA 03ATEX1074 X, issue 4

Notified body 0344: DEKRA Certification BV, Meander 1051, 6825 MJ, Arnhem, The Netherlands.

Additionally, for options applicable or safe area versions:

Low Voltage Directive 2006/95/EC EN61010-1:2010

The last two digits of the year in which the CE marking was affixed: 03.

Remark: compliance is not affected by standards EN60079-0:2012 and EN60079-11:2012.

Fluidwell BV



I. Meij, Product Manager

Note: Fluidwell BV are ISO9001 certified by DEKRA Certification BV, Meander 1051, 6825 MJ, Arnhem, The Netherlands.



**Fluidwell bv**  
P.O. Box 6 • 5460 AA • Veghel  
Vultaweg 23 • 5466 AZ • Veghel  
The Netherlands

Telephone: +31 (0) 413 - 343 786  
Telefax: +31 (0) 413 - 363 443  
Email: displays@fluidwell.com  
Internet: www.fluidwell.com

Trade Reg. No: 17120985  
VAT No: NL8085.29.699.B.01  
Bank: ING-Bank  
SWIFT Nr / BIC: INGBNL2A

EUR account no.: 66.63.96.078  
IBAN: NL73 INGB 0666 3960 78  
USD account no.: 02.20.81.771  
IBAN: NL22 INGB 0022 0817 71

All agreements, sales and deliveries are in accordance with our General Terms and Conditions which are available on our website or upon request. Any other conditions are herewith explicitly rejected by us.

LIST OF CONFIGURATION SETTINGS			
SETTING	DEFAULT	DATE :	DATE :
<b>1 - TOTAL A</b>	Enter your settings here		
11 unit	L		
12 decimals	0000000		
13 K-factor	0000001		
14 decimals K-factor	0		
<b>2 - FLOWRATE A</b>			
21 unit	L		
22 time unit	/min		
23 decimals	0000000		
24 K-factor	0000001		
25 decimals K-factor	0		
26 filter	01		
27 period time	1.0 sec.		
<b>3 - TOTAL B</b>			
31 K-factor	0000001		
32 decimals K-factor	0		
<b>4 - FLOWRATE B</b>			
41 K-factor	0000001		
42 decimals K-factor	0		
<b>5 - DISPLAY</b>			
51 function	total		
52 calculate	differential		
53 measurement	bi-directional		
54 stationary flowrate	0 L/ min		
55 stationary total	0 L/hr	/hr	/hr
<b>6 - POWER MANAGEMENT</b>			
61 LCD-new	1 sec.		
62 mode	operational		
<b>7 - FLOWMETER</b>			
71 signal A	coil-lo		
72 signal B	coil-lo		
<b>8 - ANALOG OUTPUT</b>			
81 output	disabled		
82 min. flowrate	0000000		
83 max. flowrate	9999999		
84 cut off percentage	0.0%		
85 tune min - 4mA	0208		
86 tune max - 20mA	6656		
87 filter	01 (off)		
<b>9 - PULSE OUTPUT</b>			
91 impulse width	010 periods		
92 pulse per	0001000		
<b>A - COMMUNICATION</b>			
A1 baud-rate	2400		
A2 address	1		
A3 mode	BUS-RTU		
<b>B - OTHERS</b>			
B1 model	F116-P		
B2 s-version	02.05.xx		
B3 serial nr	xxxxxxx		
B4 password	0000		
B5 tagnumber	0000000		

## Limited Warranty Policy

Great Plains Industries, Inc. 5252 E. 36<sup>th</sup> Street North, Wichita, KS USA 67220-3205, hereby provides a limited warranty against defects in material and workmanship on all products manufactured by Great Plains Industries, Inc. This product includes a 2 year warranty. Manufacturer's sole obligation under the foregoing warranties will be limited to either, at Manufacturer's option, replacing or repairing defective Goods (subject to limitations hereinafter provided) or refunding the purchase price for such Goods theretofore paid by the Buyer, and Buyer's exclusive remedy for breach of any such warranties will be enforcement of such obligations of Manufacturer. The warranty shall extend to the purchaser of this product and to any person to whom such product is transferred during the warranty period.

The warranty period shall begin on the date of manufacture or on the date of purchase with an original sales receipt. This warranty shall not apply if:

- A. the product has been altered or modified outside the warrantor's duly appointed representative;
- B. the product has been subjected to neglect, misuse, abuse or damage or has been installed or operated other than in accordance with the manufacturer's operating instructions.

To make a claim against this warranty, contact the GPI Customer Service Department at 316-686-7361 or 888-996-3837. Or by mail at:

Great Plains Industries, Inc.  
5252 E. 36<sup>th</sup> St. North,  
Wichita, KS, USA 67220-3205

If you are outside North or South America contact:

Great Plains Industries – Australia  
1/16 Atkinson Road,  
Taren Point NSW 2229, Sydney, Australia

The company shall, notify the customer to either send the product, transportation prepaid, to the company at its office in Wichita, Kansas, or to a duly authorized service center. The company shall perform all obligations imposed on it by the terms of this warranty within 60 days of receipt of the defective product.

GREAT PLAINS INDUSTRIES, INC., EXCLUDES LIABILITY UNDER THIS WARRANTY FOR DIRECT, INDIRECT, INCIDENTAL AND CONSEQUENTIAL DAMAGES INCURRED IN THE USE OR LOSS OF USE OF THE PRODUCT WARRANTED HEREUNDER.

The company herewith expressly disclaims any warranty of merchantability or fitness for any particular purpose other than for which it was designed.

This warranty gives you specific rights and you may also have other rights which vary from U.S. state to U.S. state.

Note: In compliance with MAGNUSON MOSS CONSUMER WARRANTY ACT – Part 702 (governs the resale availability of the warranty terms).

Wichita · Sydney · Mexico City

GREAT PLAINS INDUSTRIES



### Wichita - Headquarters

Great Plains Industries, Inc.  
5252 E. 36<sup>th</sup> St. N.  
Wichita, KS 67220-3205  
**316-686-7361**  
**GPI.net**

### Sydney - Manufacturing & Sales

Great Plains Industries Australia  
1/16 Atkinson Road  
Taren Point, NSW, 2229, Australia  
**+61 2 9540 4433**  
**flomec.com.au**

### Mexico - Sales Office

Great Plains Industries S De RL DE CV  
Av. Fray Luis de Leon 8051  
Oficina 13 Centro Sur  
Queretaro, Qro., Mexico 76090  
**+52 (442) 229-3139**