



E112 EXPLOSION PROOF TOTALIZER & FLOW RATE INDICATOR

APPLICATIONS

The E112 by FLOMEC® offers you an enclosure designed to be used in rough and tough applications, beyond being just explosion proof. Its sturdy design and ease of use are unequaled by any other explosion proof indicator in the market. The E112 is always your first and safest choice in explosion proof applications.

BENEFITS

- Save time with the easy-to-operate through glass keypad: no need to remove the front cover nor to arrange a work permit.
- Easy installation with the spacious chamber and plug and play connectors.
- Cost saving with an easy to install, 1" NPT thread for flow meter mounting.
- Long life duration in extremely salty atmospheres (off-shore) with heavy duty stainless steel Exd enclosure.
- Key information at a glance as the display shows flow rate, total, measuring units and a flow rate indicating speedometer.

PRODUCT CONFIGURATION

STANDARD CONFIGURATION 1

E112 = Explosion proof display

FLOWMETER INPUT SIGNAL 2

P = Pulse input: Coil, NPN, PNP, Namur, Reed-switch

ANALOG OUTPUT SIGNAL 3

AH = Galvanically isolated, Loop powered 4-20mA output

COMMUNICATION 4

CX = No communication

ENCLOSURE TYPES - IP66, IP67 / NEMA 4X / NEMA 7 / NEMA 8 / NEMA 9

HAA = Diecast Aluminum Entry threads 2 X 3/4" NPT / 1 X 1" NPT 5

HSA = Stainless Steel Entry threads 2 X 3/4" NPT / 1 X 1" NPT

ADDITIONAL INPUTS 6

IB = Remote input to reset total or to lock the "Clear Total" button

OUTPUTS 7

OT = Passive transistor output - standard configuration

POWER REQUIREMENTS 8

PX = Basic power input 9 - 27 VDC (no real sensor supply)

PB = Lithium battery powered (Both PX & PB)

HAZARDOUS AREA 9

XD = Explosion proof enclosure according ATEX and IECEx (CSA and FM Pending)

OTHER OPTIONS 10

ZB = Backlight is included as standard

1 2 3 4 5 6 7 8 9 10
>>>> E112 - P - AH - CX - HAA - IB - OT - PX - PB - XD - ZB - FL

FEATURES

- Selectable on-screen engineering units; volumetric or mass
- 7 digit flow rate / total and 11 digit accumulated total
- 16 point linearization of the flow curve - with interpolation
- Power options: Loop powered, battery and 8 - 30V DC
- Isolated, loop powered 4 - 20mA output according to linearized flow rate
- Scaled pulse output according to linearized accumulated total
- Ability to process all types of volumetric or mass flow-meter signals: Reed-switch, NAMUR, NPN/PNP pulse, Sine wave (coil), Active pulse signals. (0)4 - 20mA and 0 - 10V DC analog inputs are pending.

SPECIFICATIONS

Display:	
Type	High intensity transreflective numeric and alpha-numeric LCD, UV resistant, with bright backlight. Intensity can be adjusted via keypad.
Digits	Seven 12mm (0.47 in.) and eleven 7mm (0.28 in.) digits. Various symbols and measuring units.
Refresh rate	User definable: 8 times/sec to 30 secs.
Speedometer	To indicate the actual flow rate the bargraph runs from 0 to 100% in 20 blocks, each block is 5%.
Operating Temperature (Operational):	
-40°F to +158°F (-40°C to +70°C)	
Power Requirements:	
9 - 27V DC. Power consumption maximum 4.2 Watt. Long life Lithium battery - lifetime depends upon settings and configuration - up to approximately 2 years	
Sensor Excitation:	
Terminal S3: 3V DC for pulse signals and 1.2V DC for coil pick-up	
<i>Note:</i> This is not a real sensor supply. Only suitable for sensors with a very low power consumption like coils (sine wave) and reed switches.	
Hazardous Area - Explosion Proof:	
ATEX Certification:	Ex II 2 G Ex IIC T6 Gb Ex II 2 D Ex IIIC T85°C Db
IECEX Certification	Ex d IIC T6 Gb Ex tb IIIC T85°C Db
FM / CSA c-us Certification	Explosion-proof for use in Class I, Division 1, Groups A, B, C, D DIP (Dust-Ignition-proof): Class II, Division 1, Groups E, F and G. Class III, hazardous (classified) locations
Ambient to:	-40°F to +158°F (-40°C to +70°C)
Hazardous Area - Directives:	
EMC:	Compliant ref. EN61326-1 and FCC 47 CFR part 15
Low voltage:	Compliant ref. EN61010-1
Signal Input (Flowmeter):	
	Coil / sine wave (COIL-HI: 20mVpp or COIL-LO: 80mVpp - sensitivity selectable), NPN / PNP, open collector, reed switch, Namur, active pulse signals 8 - 12 and 24V DC
Frequency:	Minimum 0Hz - maximum 7kHz for total and flow rate. Maximum frequency depends on signal type and internal low-pass filter. E.g. reed switch with low-pass filter. Maximum frequency 120Hz.
K-Factor	0.000010 - 9,999,999 with variable decimal position
Low-pass filter	Available for all pulse signals

External Reset Total:	
Function:	<ul style="list-style-type: none"> Terminal input to reset total remotely If this terminal input is closed, the "clear total" function is disabled
Type:	Internally pulled-up switch contact - NPN
Duration:	Minimum pulse duration 100msec
Signal Output (Digital):	
Function:	Pulse output. Transmitting accumulated total
Frequency:	Maximum 500Hz. Pulse length user definable between 1 msec up to 10 seconds
Type OT:	One passive transistor output (NPN) - not isolated. 300mA - 50V @25°C (77°F)
Signal Output (Analog):	
Function:	Transmitting linearized flow rate
Accuracy:	12 bit. Error < 0.1%. Analog output signal can be scaled to any desired range.
Type AH:	Galvanically isolated, loop powered 4-20mA output
Accumulated Total - 11 digits:	
Units / Decimals:	According to selection for total
Note:	Can not be reset to zero
Flow rate - 7 digits, 0 - 1 - 2 or 3 decimals:	
Units:	mL, L, m³, Gallons, kg, Ton, lb, bl, cf, RND, ft³, scf, Nm³, NI, igal - no units
Time units:	/sec - /min - /hr - /day

DIMENSIONS

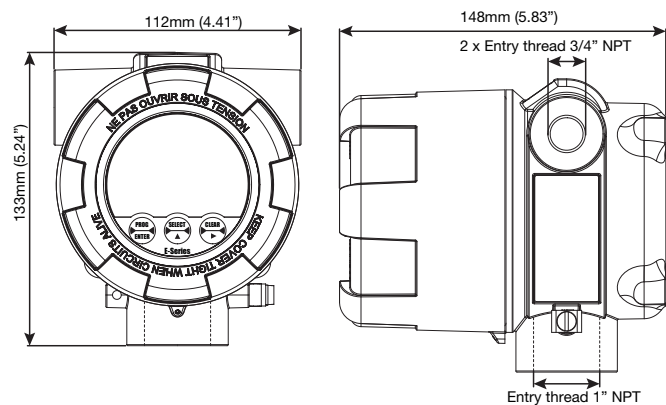

ACCESSORIES

Part No.	Description
FW-ABB04	1 X 3/4 inch NPT plug
FW-ABB05	1 X 1 inch NPT plug
FW-ACE03	Wall Mounting Kit (SS)

APPROVALS



Service & Warranty: For technical assistance, warranty replacement or repair contact your **FLOMEC®** or **GPI®** distributor: In North or South America: **888-996-3837 / GPI.net**
Outside North or South America: **+61 2 9540 4433 / flomec.com.au**