

BAT D/T MILLENNIUM

LCD Dual Totalizer (Resettable & Non-Resettable)

Features

- UL/C-UL Intrinsically Safe Listed
- Magnetic Pickup Input, Contact Closure Input, DC Pulse Input (Optically Isolated)
- Displays 5 Digit Resettable Total
8 Digit Grand Total
- 4-20mA Analog Output (optional)
- Powered From Internal Battery, External DC Supply or 4-20 mA Output Loop
- 20 Point Linearization (optional);
10 Point Linearization with Data Logger option
- Isolated Pulse Output
- Nonvolatile Flash Memory of Setup Data
- RS485 Modbus Communications and Data Logger (optional)
- Setup Software Available for Easy Programming and Monitoring Using a PC and Special Serial Cable

Description

Featuring 5 digits of resettable total and 8 digits of grand total, the BAT D/T Millennium (BATDTM) is a battery powered indicator capable of accepting magnetic pickup, DC pulse and switch closure inputs from pulse producing flowmeters. A scaled pulse output is standard. A 4-20mA loop and/or linearization is optional.

Specifications

DISPLAY:

Resettable Total Display

5 Digits (99999), 0.35" High, Display updates once every second (8 times per second if loop powered)

Grand Totalizer Display: (selectable decimal)

8 Digits (99999999), 0.2" High

Totalizer Descriptors: GAL, LIT, FT3, M3, "blank"

Warning Displays: Low battery warning

PULSE OUTPUT:

The pulse output advances with the least significant digit of the totalizer or decimal multiples thereof (see Pulse scale divider).

Type: Isolated photomos relay

Max. voltage (off state): 30 VDC

Current (on state): 100mA

Pulse Duration: Selectable 0.5, 0.25, 0.125, 0.0625 seconds

Pulse Scale divider (Pulscale): User selectable, +1, +10, +100 or OFF

NOTE: Select OFF for max. battery life.



Mounting Style 1



Mounting Style 2



Mounting Style 3



Mounting Style 3NE



Mounting Style 3SS



Mounting Style 5



Mounting Style 6

POWER:

BATTERY POWERED

Supplied with 2 C size Lithium battery pack.

EXTERNAL POWER INPUT

Voltage: 8.5 to 30 VDC

Current: Less than 5 mA

Supplied with 1 C size lithium battery for standby operation

Protection: Reverse Polarity Protection on DC Power Input

LOOP POWERED

Voltage: 8.5 to 30 VDC

Supplied with 1 or 2 C size lithium battery(ies) for standby operation

Protection: Reverse Polarity Protection on Current Loop

Loop Burden: 8.5V maximum

BATTERY LIFE EXPECTANCY:

Expected Years of Operation for BATDT-M of various powering options at equipment duty cycles

MODEL	RUN TIME			
	Idle	2hrs/day	8hrs/day	24hrs/day
BATDT-M-A	10 yrs	10 yrs	10 yrs	9.1 yrs
BATDT-M-A-4	10 yrs	10 yrs	10 yrs	8.4 yrs
BATDT-M-B/C	10 yrs	10 yrs	10 yrs	10 yrs

standby-operation

BATDT-M -B/C	Indefinite operation when externally powered			
External or loop power				

NOTE: Battery shelf life is rated at 10 years by manufacturer Life expectancy based on rated battery capacity at 20°C The above table is shown with pulse output inactive. Use of pulse output shortens battery life. **Example:** A pulse output of 0.06 sec. duration, once per second, would derate the battery life by 20%.

ACCURACY:

±1 count

SAFETY LISTINGS (Mounting Styles 3, 3NE, 3SS):

CSA File 091109 (cert. 1120094)

UL/C-UL File E225832

CLASS 1, DIV 1, GROUPS B, C, D

Additional "enclosure only" approvals available for ATEX and IEC

ENVIRONMENTAL:

OPERATING TEMPERATURE

-4°F (-20°C) to + 158°F (70°C)

Extended Temp: -22°F (-30°C) to + 158°F (70°C)

HUMIDITY

0 - 90% Noncondensing

MOUNTING STYLES:

- 0- Circuit Board- OEM option (consult factory)
- 1- Panel Mount - NEMA 4X Front
- 2- Wall Mount - NEMA 4X Enclosure (keypad mounted behind clear cover)
- 3- Explosion Proof - Class I, Division I, Groups B, C & D Class II, Division I, Groups E, F & G White, Includes Third Conduit Entry
- 3NE- Explosion Proof - Class I, Division I, Groups B, C & D Class II, Division I, Groups E, F & G Stainless Steel
- 3SS- Explosion Proof - Class I, Division I, Groups B, C & D Class II, Division I, Groups E, F & G NEMA 4X Enclosure (keypad mounted on cover)
- 5- Wall Mount - NEMA 4X Enclosure (keypad mounted on cover)
- 6- Double Ended Explosion Proof - Class I, Division I, Groups B, C & D Class II, Division I, Groups E, F & G (contact factory for details)

NOTE: Meter mounting kits available for styles 2, 3, 5 and 6 Consult Factory

INPUTS:

MAGNETIC PICKUP INPUT

Frequency Range: 0 to 3500 Hz

Trigger Sensitivity: 10 mV p-p

Over Voltage Protected: ± 30 VDC

OPTO-ISOLATED DC PULSE INPUT

High (logic 1): 4-30 VDC

Low (logic 0): Less Than 1 VDC

Minimum Current: .5 mA

Hysteresis: 0.4 VDC

Frequency Range: 0 to 5 kHz

Min. Pulse Width: 0.1 msec

CONTACT CLOSURE INPUT (contact closure to common)

Internal Pullup Resistor: 100 KΩ to +3.6 VDC

High (logic 1): Open or 4-30 VDC

Low (logic 0): Less Than .5 VDC

Internal Switch Debounce Filter: 0 to 40 Hz

NOTE: Sustained contact closure will shorten battery life.

RESET INPUT (contact closure to common)

Internal Pullup Resistor: 100 KΩ to +3.6 VDC

High (logic 1): Open or 4-30 VDC

Low (logic 0): Less Than .5 VDC

Minimum On : 25 msec

NOTE: Sustained contact closure will shorten battery life.

K-FACTOR

Range: 0.001 to 99999999

Decimal Point Locations: XXXX.XXXX to XXXXXXXX

20 Point Linearization Option (10 Point with Data Logger option)

This feature allows the user to enter 20 different frequencies with 20 different corresponding K-Factors to linearize non linear signals.

ANALOG OUTPUT OPTION:

Type: 4-20 mA follows rate computation, Two wire hookup

Accuracy: 0.025% Full Scale at 20° C

Temperature Drift:

50 ppm/°C Typical

Reverse Polarity Protected

Update Rate: 8 times/second

NOTE: The BATDT-M uses the 4-20 mA loop power as its primary power source when this option is used. The battery is still required for standby battery operation. Selectable analog output damping.

COMMUNICATIONS OPTION (S1):

RS232 SERIAL SETUP SOFTWARE OPTION:

This option enables you to access a variety of process parameters through serial communications. PC compatible communications software is included with this option. With this software and a BATDTM Serial Adapter Cable (BSAC1) you will be able to setup the BATDTM through your PC.

DATA STORAGE:

Setup Information: Stored in flash memory

Totalizer: Stored in battery backed RAM but can be saved to flash memory by operator for recall after battery change out.

RS-485 MODBUS and DATA LOGGER OPTION (S2):

The optional RS-485 card utilizes Modbus RTU protocol to access a variety of process parameters. The Data Logger stores the totalizer to flash memory once every 24 hours at the time you set. The data logger can hold 24 days of totals, on the 25th day the oldest total in the logger is dropped. Requires external DC power: 6-28VDC (input is reverse polarity protected)

Current Draw:

Receiving: 2 mA

Transmitting: 125 mA (instantaneous peak)

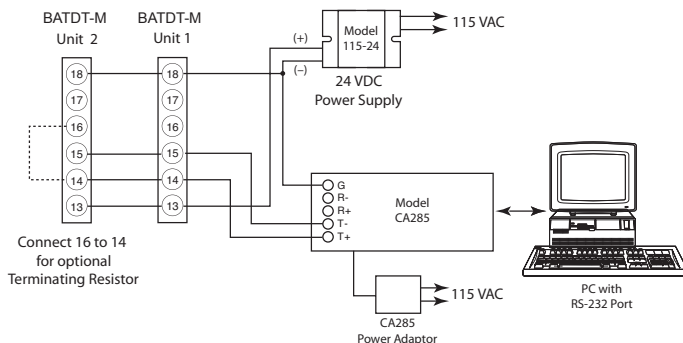

BATPACK

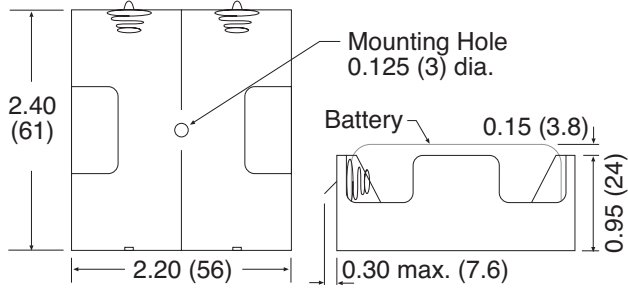

BATDT-M-0

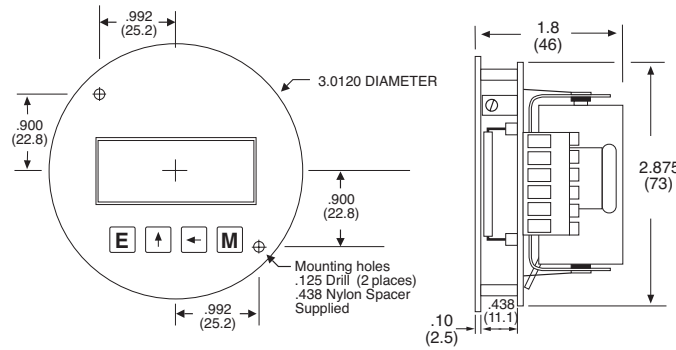

BATDT-M-1

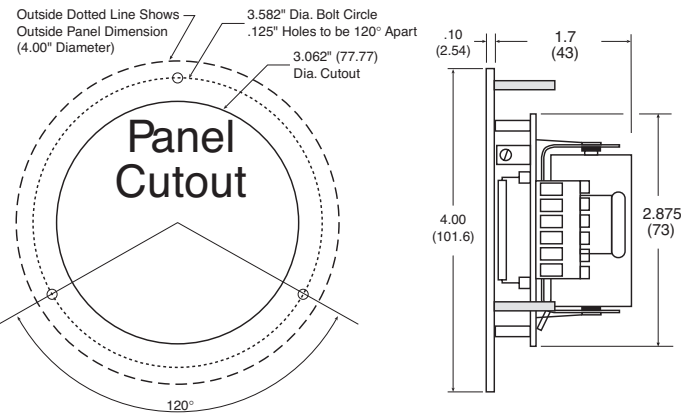

BATDT-M-2

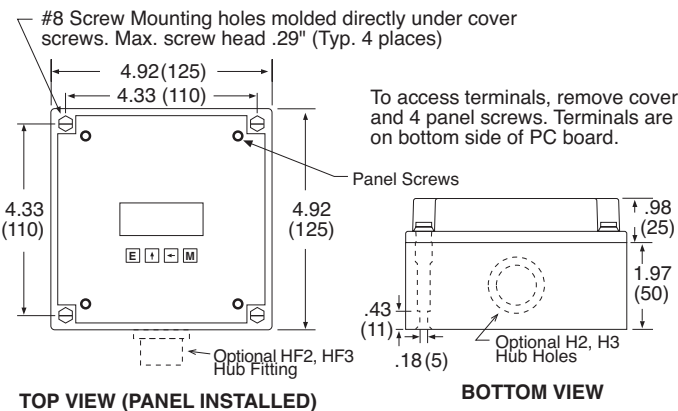

BATDT-M-3

To access terminals, unscrew cover and loosen 2 panel screws.
Terminals are on bottom side of PC board.

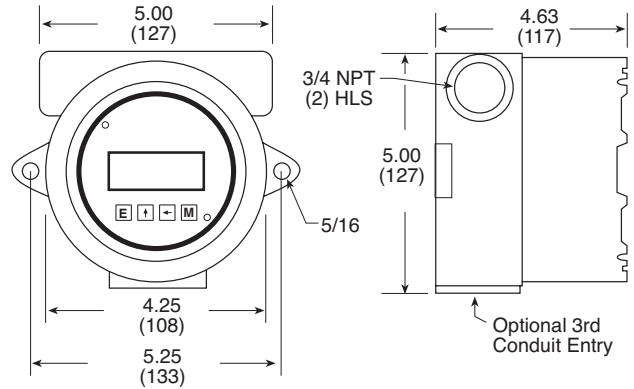

BATDT-M-3NE

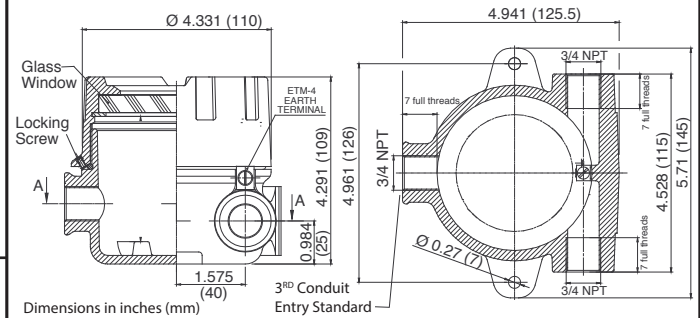

BATDT-M-3SS

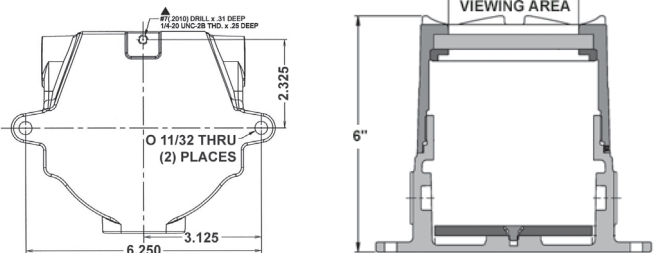

BATDT-M-5

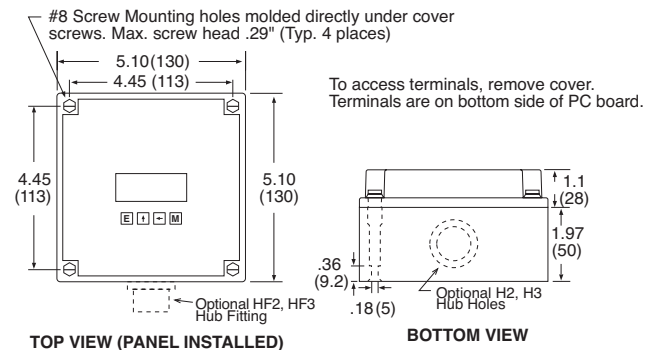

BATDT-M-6

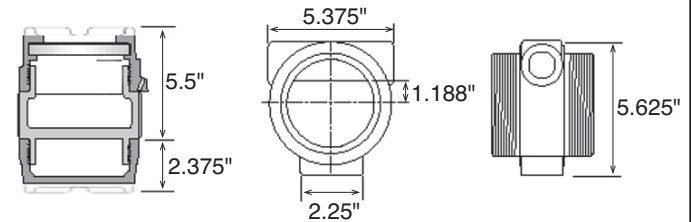

NOTE: Additional entry holes may be provided on styles 2 and 5.

Typical Wiring:

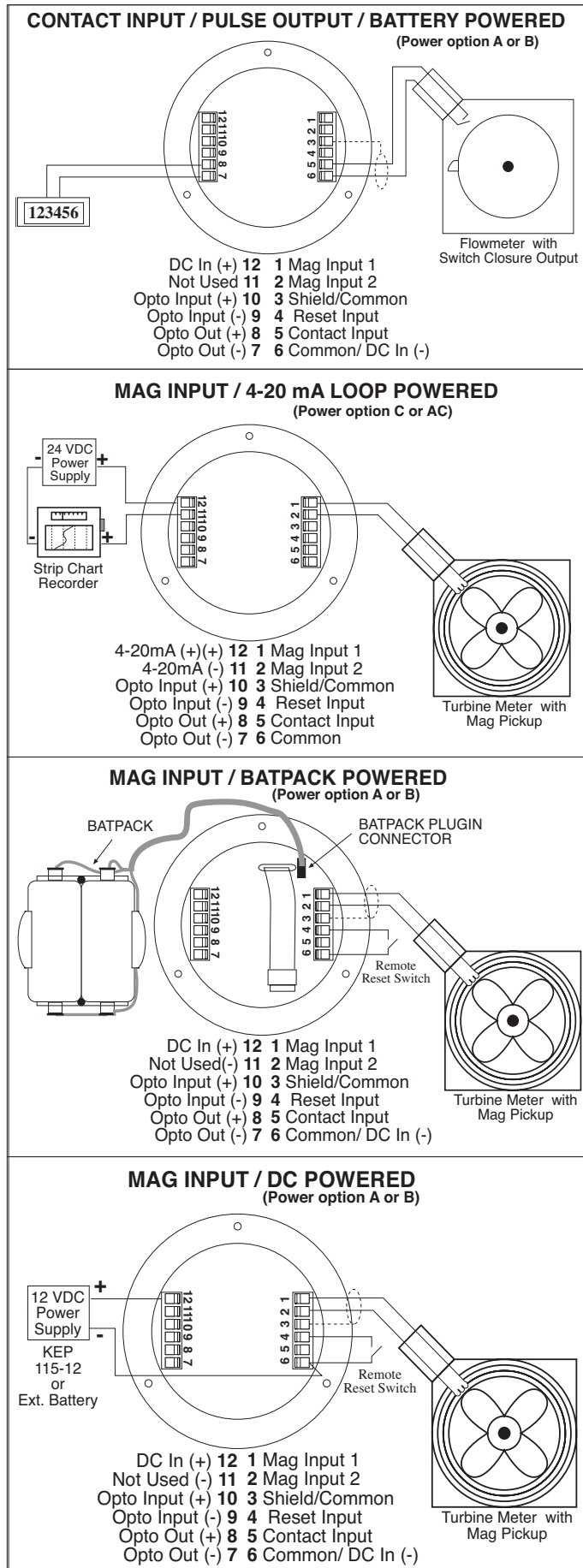

Ordering Information

EXAMPLE: BATDTM 3 A 4 ET

Series: _____

Mounting: _____

† 0 = OEM

† 1 = Panel Mount

2 = NEMA 4X Box (Keypad behind clear cover)

3 = Explosion Proof Housing

3NE = Explosion Proof Housing, White
Includes Third Conduit Entry

3SS = Stainless Steel Ex-Proof Housing (consult factory)

5 = NEMA 4X Box (Keypad outside opaque cover)

6 = Double Ended Explosion Proof Housing

Power Supply: _____

† A = Battery (2 supplied)

B = External Power Supply (8.5 to 30 VDC)

C = Loop Powered with 4-20 mA Output

AC = Loop Powered with 4-20 mA Output and 2 Batteries

Options (Multiple Options Available)

S1 = Serial Setup Software for use with BSAC1

S2 = RS485/Modbus/Data Logger - Isolated (power options B, C only)

4 = 20 Point Linearization (10 point with S2 option)

D = Rate per Day, Hour or Minute

ET = Extended Temp.: -22°F to 158°F (-30°C to 70°C)

CE** = CE Compliant

CSA** = CSA Listed Explosion Proof

IS** = UL/C-UL Listed IS

TRX = NEMA7 Explosion Proof Reset Switch
on Third Conduit Entry (mounting style 3 only)

RN = External Magnetic Reset

T = Third Conduit Entry in Ex-Proof Housing (mounting style 3)

H2 = 0.875" Hole for mounting styles 2 and 5

HF2 = 0.5" Female NPT Hub fitting for mounting styles 2 and 5

H3 = 1.125" Hole for mounting styles 2 and 5

HF3 = 0.75" Female NPT Hub fitting for mounting styles 2 and 5

Accessories:

BATPACK= External Batt. Pack with 2 C Size Batteries & 12" leads

BATC = Single Battery: Tadiran P/N TL2200/S 3.6V 7200mAh or equal

115-24 = 115 VAC to 24 VDC power supply

BSAC1 = RS232 Serial Adapter Cable with setup software

* External battery pack supplied with models BATDTM0A & BATDTM1A

** Contact factory for latest information