



FLOW METER LIMITED WARRANTY

Meters are warranted against defects in materials and workmanship to the original user for a period of thirteen (13) months from the date of factory shipment, provided the meter is installed, operated and maintained in accordance with King Instrument Company's instructions and recommendations.

This warranty does not apply if failure is caused or contributed to by any of the following: improper handling, improper storage, abuse, unsuitable application of the product, lack of reasonable and necessary maintenance, use exceeding suggested pressure and temperature maximums, improper packaging for return, or repairs made or attempted to be made by anyone other than King Instrument Company, Inc.

KING INSTRUMENT COMPANY, INC. MAKES NO WARRANTY AS TO THE FITNESS OF ITS PRODUCTS FOR SPECIFIC APPLICATIONS.

This warranty is valid for the original end-user only and does not apply to products that have been damaged or modified. This warranty is non-transferrable and is limited to replacement or repair. The liability of King Instrument Company arising out of its supply of the products, or their use, shall not in any case exceed the cost of correcting defects in the products as set forth above.

THIS WARRANTY IS A LIMITED WARRANTY AND SHALL BE IN LIEU OF ANY OTHER WARRANTIES, EXPRESSED OR IMPLIED, INCLUDING BUT NOT LIMITED TO ANY IMPLIED WARRANTY OR MERCHANTABILITY OR FITNESS FOR A PARTICULAR PURPOSE. THERE ARE NO OTHER WARRANTIES WHICH EXIST BEYOND THE DESCRIPTION OR FACE HEREOF.

IN NO EVENT SHALL KING INSTRUMENT COMPANY BE LIABLE FOR LOSS OF PROFITS, INDIRECT, CONSEQUENTIAL OR INCIDENTAL DAMAGES.

Products should be returned, prepaid, to King Instrument Company, Inc. with proof of purchase. Call factory for Return Merchandise Authorization (RMA) number and return instructions.

THIS IS IMPORTANT INFORMATION. READ IT CAREFULLY BEFORE BEGINNING WORK.

- 1) Inspect meter for damage that may have occurred during shipping. Report any damage to the container to the freight carrier immediately.
- 2) Make sure your pressure, temperature, fluid and other requirements are compatible with the meter (including o-rings.)
- 3) Select a suitable location for installation to prevent excess stress on the meter which may result from:
 - a) Misaligned pipe.
 - b) The weight of related plumbing.
 - c) "Water Hammer" which is most likely to occur when flow is suddenly stopped as with quick closing solenoid operated valves. (If necessary, a surge chamber should be installed. This will also be useful in pressure start-up situations.)
 - d) Thermal expansion of liquid in a stagnated or valve isolated system.
 - e) Instantaneous pressurization which will stress the meter and could result in tube failure.
- 4) Handle the meter carefully during installation.
 - a) Use an appropriate amount of teflon tape on external pipe threads before making connections. Do not use paste or stick type thread sealing products.
- 5) Install the meter vertically with the inlet port at the bottom.
- 6) Meters with stainless steel fittings will support several feet of pipe as long as significant vibration or stress resulting from misaligned pipe are not factors.

ADDITIONALLY

7310 Series meters are designed for vertical installation only. (Inlet at bottom, Outlet at top)

Max Non-Shock Pressure and Temperature		
Fitting	Temp	Pressure
316LSS	200° F	200 psig (41W-103W)
PVC & PVDF	130° F	150 psig (41W-72W)
		125 psig (90W-103W)
Ambient Temp. 33° F -125° F		

NOTE: In closed thermal transfer or cooling systems, install the meter in the cool side of the line to minimize meter expansion and contraction and possible fluid leaks at the threaded connections.

CAUTION

- O-rings should be replaced if meter is disassembled after it has been in service.
- Serious property damage and great personal injury could occur as the result of a meter misused or used in an unsuitable application.

CLEANING:

Carefully remove the flowmeter from piping system. Remove the 4 end fitting retainer screws. Carefully remove the end fitting and end fitting retainer. Carefully remove the polysulfone tube from the top. Be sure to not let the internals fall out. Use caution when removing the polysulfone tube. Do not allow float to fall out. Float damage may result in inaccuracy. All necessary instrument components are now fully accessible for cleaning with a bottle brush and appropriate mild soap solution*. Before the meter is reassembled, inspect all parts for damage. O-rings should be replaced during meter maintenance and cleaning.

*Do not use cleaning agents that will damage float, tube or o-rings.

To reassemble, carefully guide the polysulfone tube back into the case. Reinstall the top end fitting and end fitting retainer. Tighten the 4 end fitting retainer screws. Reinstall the instrument into the plumbing system after removing the old teflon tape (with a wire brush) and replacing with fresh teflon tape.

Meters should be cleaned with a mild soap solution. This will be an effective cleaner of rust stains. Caution must be used so that materials of construction are not damaged by cleaning solutions. Hard water deposits can be removed with 5% acetic acid solution (vinegar).

REPAIR

7310 meters that require repair should be sent to the factory. Please call for a Return Merchandise Authorization (RMA) number and return instructions.

WARNING:

Pressure and temperature ratings are based on a study of the engineering data for particular materials used in construction and on the design of individual models. This information is supplemented by destructive test results. Meters with stainless enclosures must never be operated without shields securely in place. Meters exposed to difficult environments such as those created by certain chemicals, excessive vibration or other stress inducing factors could fail at or below the suggested maximums. Never operate meters above pressure and temperature maximums. It is strongly recommended that all meter installations utilize an appropriate pressure relief valve and/or rupture disc. The pressure settings and locations of these devices should be such that meters cannot be over pressurized. Meter failure could result in damage to equipment and serious personal injury. Always use suitable safety gear, including OSHA approved eye protection when working around meters in service. We are happy to pass along chemical compatibility information that has been published by the manufacturer's of raw materials used in our products; however, this information should not be construed as a recommendation made by King Instrument Company, Inc. for a specific application.

FLOAT TYPES AND ORIENTATIONS



GV FLOAT

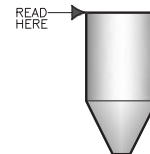

SL FLOAT

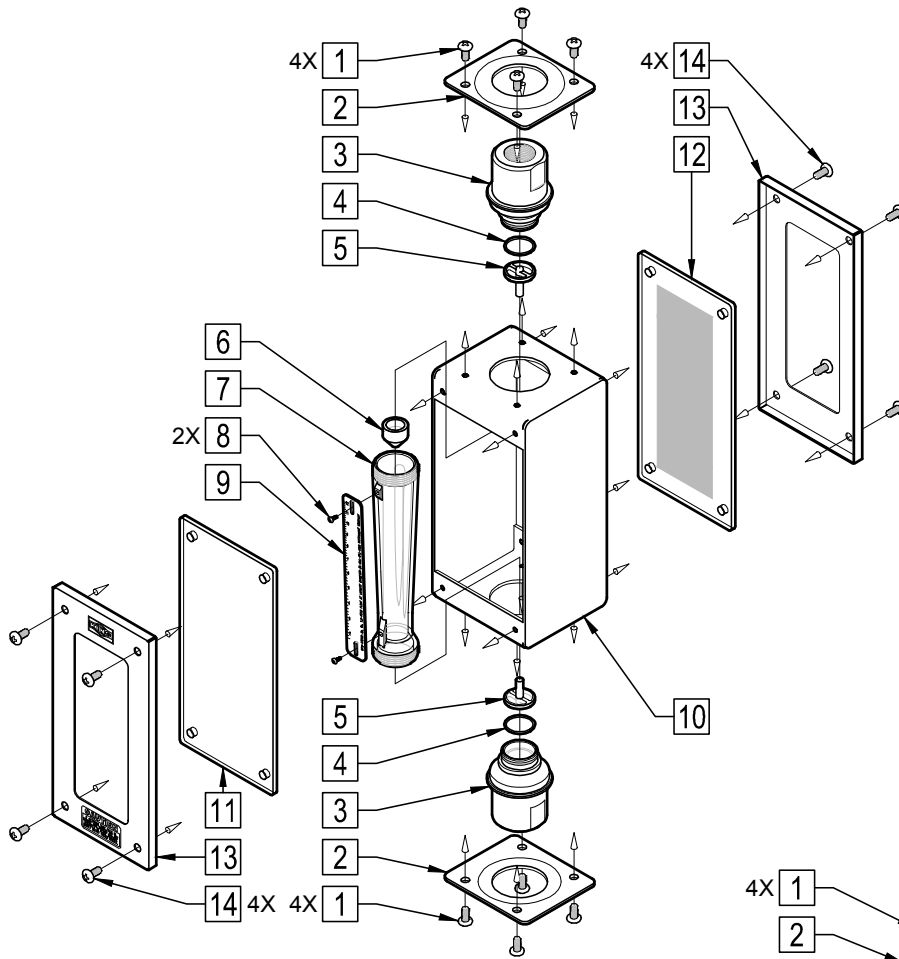

7310 SERIES ASSEMBLY RIB GUIDED TUBE PARTS LIST:

1. End Fitting Retainer Screw
2. End Fitting Retainer
3. End Fitting
4. End Fitting O-Ring
5. Float Stop / Extension Assembly
6. Float
7. Polysulfone Meter Tube
8. Scale Plate Screw
9. Scale Plate
10. Case
11. Shield (Clear)
12. Shield (White)
13. Shield Cover
14. Shield Cover Screw

7310 SERIES ASSEMBLY POLE GUIDED TUBE PARTS LIST:

1. End Fitting Retainer Screw
2. End Fitting Retainer
3. End Fitting
4. End Fitting O-Ring
5. Float Stop / Guide Rod Assembly
6. Float
7. Polysulfone Meter Tube
8. Scale Plate Screw
9. Scale Plate
10. Inlet Float Stop
11. Case
12. Shield (Clear)
13. Shield (White)
14. Shield Cover
15. Shield Cover Screw

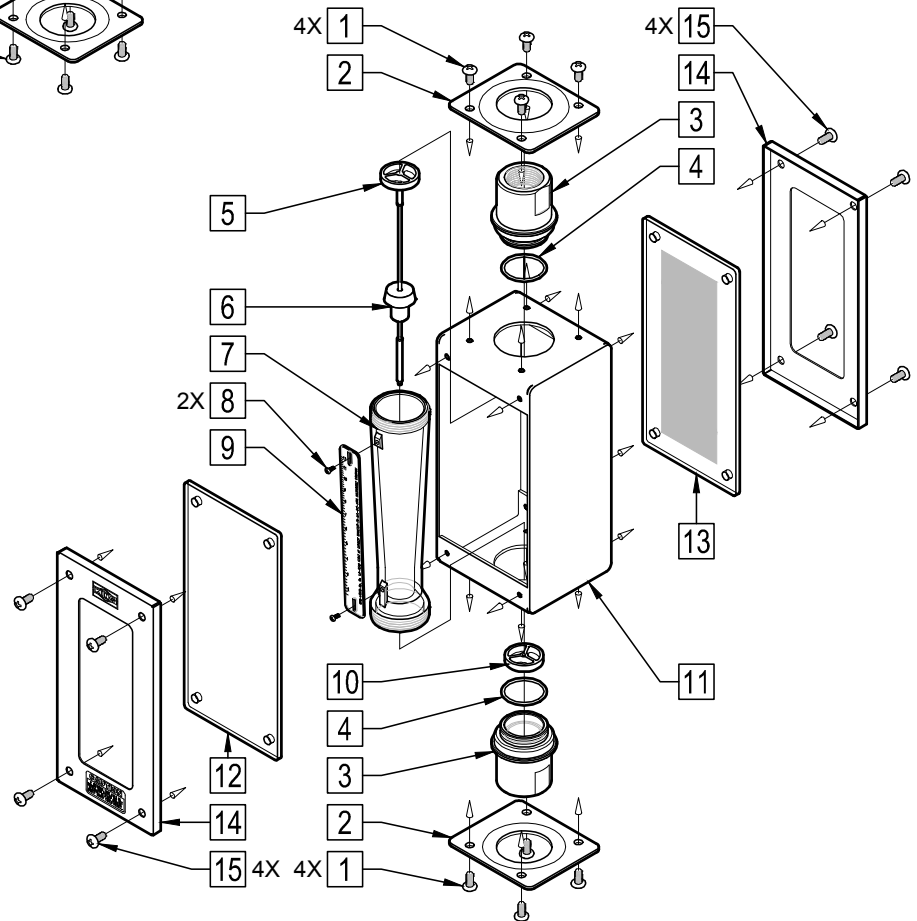

LATCHING REED SWITCH

All 7310 Series flowmeters may be fitted with one or two latching reed switches.

The switch assembly is mounted on the meter tube. The switch can be positioned to trip at any point on the scale.

The switch is a reed type and uses a biasing magnet to give it the latching feature. The float contains hermetically sealed magnet(s), so when the float comes in proximity to the switch it closes and remains closed (latched) when the float moves below the switch it resets itself. Contact King Instrument Company for multiple switch options.

LATCHING REED SWITCH ELECTRICAL SPECIFICATIONS

TYPE:	SPDT / Latching
MAXIMUM CONTACT VOLTAGE:	100V DC
MAXIMUM CONTACT CURRENT:	0.20a DC
MAXIMUM CONTACT POWER:	4 Watts DC
BREAKDOWN VOLTAGE:	200V DC
STANDARD PULL-IN RANGE:	15-40 Ampere turns
INITIAL CONTACT RESISTANCE:	0.150 Ohm

CONNECTIONS-INTRINSICALLY SAFE WIRING

SWITCH ISOLATOR 3 CONDUCTOR, 22Awg, 2' Long

- 1) White - N.O. switch output 1
- 2) Red - Common
- 3) Black - N.C. switch output 2

SWITCH ISOLATOR OPTION:

Latching reed switches can be used as stand alone devices, or may be connected to a switch isolator for intrinsically safe applications. The purpose of the switch isolator is to supply electrical signals between safe and hazardous areas in either direction while limiting the amount of energy that can be transferred even under fault conditions. Switch isolators are available with 220VAC, 110VAC or 24VDC supply voltage requirements, contain single pole double throw (SPDT) relays, and are DIN rail mountable. See switch isolator specifications for electrical connections and further details.

7310 SERIES WITH ALARM PARTS LIST:

1. End Fitting Retainer Screw
2. End Fitting Retainer
3. End Fitting
4. Magnetic Float
5. Polysulfone Meter Tube Assembly
6. Case
7. Shield (Clear)
8. Shield (White)
9. Shield Cover
10. Shield Cover Screw
11. Alarm Switch
12. Alarm Switch Housing
13. Alarm Set Screw O-Ring
14. Alarm Set Screw
15. Alarm Switch Housing Screw
16. Electrical Strain Connector
17. Junction Box O-ring
18. Junction Box With Cover
19. Junction Box Mounting Screw

