



The Standard of Measurement



## 700-LP Series Rotary Meter Liquefied Petroleum Gas (LPG)

# Installation, Operation & Maintenance Manual

© Copyright 2017 Total Control Systems

**WARNING:** This equipment is for service on flammable liquid and gas under pressure and must be installed, operated, maintained, and serviced only by qualified personnel fully trained in all safety procedures and applicable federal, state, local, and industry codes. Failure to follow proper procedures for this class of equipment can result in property damage, serious injury or death from burns, fire, explosion or other hazards.

Check us out at [www.TCSmeters.com](http://www.TCSmeters.com)!

## Table of Contents

Safety Warning Symbols	2	757-20 Differential Valve Assembly (Exploded View)	20
Receipt & Inspection	3	757-20 Differential Valve Assembly (Bill of Material)	21
Notice	3	782-20 Back Check Valve Assembly (Exploded View)	22
Authorized Use	4	Torque Specifications	23
Restrictions	4	Torque Specifications (continued)	24
Basic Safety Instructions	5	700-20 Meter Dimensions	25
Meter Overview	6	Drive Components	26
Meter Specifications	6	Disassembly of Meter	27
Material of Construction	6	Disassembly of Meter (Continued)	28
Procedures for LPG Meters	7	Disassembly of Meter (Continued)	29
System Recommendations	8	Inspection of Parts	30
Start Up Recommendations	9	Reassembly of Meter	31
Direction of Flow	10	Reassembly of Meter (Continued)	32
Meter Calibration	11	Reassembly of Meter (Continued)	33
Meter Calibration (Continued)	12	Reassembly of Meter (Continued)	34
Meter Calibration (Continued)	13	Disassembly & Reassembly of Strainer	35
Calibration Adjustment	13	Disassembly of Air Eliminator	36
Maintenance	14	Assembly of Differential Valve	37
Maintenance (Continued)	15	Assembly of In-line Check Valve	38
Storage Instructions	15	Meter Trouble Shooting	39
700-20 Meter Assembly (Exploded View)	16	Vapor Eliminator Trouble Shooting	40
700-20 Meter Assembly (Bill of Material)	17	Differential Valve Trouble Shooting	40
740-20 Vapor Eliminator/Strainer Assy. (Exploded View)	18	MSDS	41
740-20 Vapor Eliminator/Strainer Assy. (Bill of Material)	19	MSDS (Continued)	42
		Warranty Information	43

## Warning Symbols



### CAUTION

Follow the warning instructions within the following information to avoid equipment failure, personal injury or death.



### TURN POWER OFF

Before performing any maintenance, be sure to turn system power off to avoid any potential electric spark



### FLAMMABLE

Flammable liquids and their vapors may cause a fire or explosion if ignited.



### EYE PROTECTION

Pressurized systems may cause hazardous leaks and spray that may be dangerous for your eyes. Always wear eye protection around pressurized systems and its hazardous liquids.

### INJURY

Wear gloves for protection from hazardous liquids that may cause irritation or burns.



### READ

Read and understand all related manuals thoroughly. The Engineering and OIM manuals will provide the knowledge for all systems, maintenance and operation procedures. If you have any questions, please consult the factory.



## Receipt & Inspection

Upon receipt of your meter shipment, be sure to inspect the packaging and the flow meter assembly for any damage before signing the receipt for the shipment. If damage is evident or suspected, notify the delivery company and refuse receipt of the shipment.

Meters are individually boxed and are protected with packing material. Each package is identified with the flow meter assembly part number, description, direction of flow and serial number. Verify that the meter Identification Plate reflects the same model, size, and configuration as ordered. Contact your distributor if there is any discrepancy.

Meter assemblies should be handled with methods appropriate for the shape, size and weight involved. Appropriate clothing and shoes should be worn. Transport the meter package to the installation site with appropriate transportation methods, being careful not to damage the flow meter.

Be careful of any loose or protruding staples from the packaging, as they can be very sharp and may potentially cause injury.

If foam has been used to protect the meter, carefully remove the top foam layer before attempting to remove the meter assembly from the box. Foam packaging may be formed around the meter assembly making it difficult to remove. If the meter is bolted to a wood pallet, remove bolts while being careful not to let the meter tip over when the support has been removed. Do not lift the meter assembly by flex hoses, thermowells, wires, or pulsers. Also, do not lift the meter by putting objects into or through the meter. Removal of the meter assembly from its packaging without adhering to these warnings may cause serious injury or damage to the meter.

The wooden pallets and bases meet the ISPM 15 Guidelines for Regulating Wood Packaging Material in International Trade through the Timber Products Inspection Company (TP #2134).

Every effort has been made to remove the calibration fluid from the meter assembly before shipment. A Material Safety Data Sheet (MSDS) can be reviewed on Page 41. Appropriate precautions should be taken regarding any personal, environmental and material compatibility with the end use system.

## Notice

Total Control Systems (TCS) shall not be liable for technical or editorial errors in this manual or omissions from this manual. TCS makes no warranties, express or implied, including the implied warranties of merchantability and fitness for a particular purpose with respect to this manual and, in no event, shall TCS be liable for special or consequential damages including, but not limited to, loss of production, loss of profits, etc.

The contents of this publication are presented for informational purposes only, and while every effort has been made to ensure their accuracy, they are not to be construed as warranties or guarantees, expressed or implied, regarding the products or services described herein or their use or applicability. We reserve the right to modify or improve the designs or specifications of such products at any time.

TCS does not assume responsibility for the selection, use or maintenance of any product. Responsibility for proper selection, use and maintenance of any TCS product remains solely with the purchaser and end-user.

***All rights reserved. No part of this work may be reproduced or copied in any form or by any means – graphic, electronic or mechanical – without first receiving the written permission of Total Control Systems, Fort Wayne, Indiana USA.***

## Authorized Use

**Unauthorized use of the device 700-20 LPG may be dangerous to people, nearby equipment and the environment.**

- The device is used exclusively as a meter system for measuring Liquid Propane in a Hazardous Area. ATEX Explosion Group II and Temperature Class T6 (as indicated on the meter nameplate).
- Product Marking: UL MH45225 List Number
- The device complies with the requirements of UL 25, Meters for Flammable and Combustible Liquids and LP-Gas.
- The device is rated for operating pressures up to 350 PSI (24.1 bar).
- The device may be applied only as directed in the Meter Specifications and System Recommendations sections of this manual.
- The faultless and reliable operation of the metering system assumes correct installation and operation and maintenance. Any other use is regarded as unauthorized. Total Control Systems is not liable for any resulting damage. The user alone bears this risk.
- Because the unit is intended for operation at high operating pressures, all personnel involved in installation, operation and maintenance must be properly trained prior in accordance with the requirements of this manual and to applicable safety and technical protocols.
- Only use this device for its intended purpose.

## Restrictions

- Flow meters must be installed in accordance with the requirements of NFPA 58 in addition to all other State and local codes.
- The UL/ATEX Certifications are only valid if the device is used as described in these operating instructions.
- When used in conjunction with electric solenoid controls, the UL/ATEX Certification is only valid if the device used in conjunction with components that carry their own UL/ATEX Certification. Otherwise the UL/ATEX Certification for the meter device will be voided.
- If any unauthorized changes are made to the device or any components thereof, the UL/ATEX Certifications will be voided.



Failure to observe this operating manual and its operating instructions as well as unauthorized tampering with the device release Total Control Systems from any liability and also invalidates the warranty covering the device and accessories!

## Basic Safety Instructions

These safety instructions do not make any allowance for any:

- Contingencies and events which may arise during the installation, operation and maintenance of the devices.
- Local safety regulations—the operator is responsible for observing these regulations, also with reference to the installation personnel.



### **Danger of Explosion!**

- The device is part of a closed system and must not be removed during operation.
- Component parts, threaded fittings and lines attached to the meter system must not be removed during operation.

### **With Electronic Solenoids installed - Risk of Electric Shock!**

Acute risk of injury from hazardous body voltage!

- Before performing any maintenance on the metering system, switch off the power supply to any electric solenoid controls and secure to prevent reactivation.
- Observe applicable accident prevention and safety regulations for electrical equipment.

### **Danger - High Pressure!**

When disconnecting system, there is an acute risk of injury.

- Before disconnecting component parts, threaded fittings and lines attached to the meter system, turn off pumping system and close the pressure and vent the lines.
- During the installation, make certain that the flow direction is correct.
- Observe applicable accident prevention and safety regulations for pressurized devices.

### **Danger of Explosion caused by electrostatic charge!**

If there is a sudden discharge from electrostatically charged devices or persons, there is a danger of explosion in the EX area.

- Using suitable measures, ensure that no electrostatic charges can occur in the EX area.
- Clean the device surface by gently wiping it with a damp or anti-static cloth only.

### **General Hazardous Situations.**

To prevent injuries:

- Ensure that the system cannot be activated unintentionally.
- Installation and maintenance work may be carried out only by authorized technicians with the appropriate tools.
- After an interruption in the power supply or system pressure, ensure that the system is restarted in a defined and controlled manner.
- The device may be operated only when in perfect condition and in consideration of the operating instructions.

## Meter Overview

The TCS Model 700-LP series flow meter reflects a simple and efficient design for application on liquefied petroleum gas (LPG). The meter consists of a single fluid chamber that contains a single blocking rotor and two displacement rotors whose rotation is synchronized with mating gears. As the fluid enters the fluid chamber, the blocking rotor is forced to rotate. The displacement rotors, also rotating in conjunction with the blocking rotor help direct the fluid flow through the chamber and to the outlet. The linear flow of the fluid is thus translated into rotary motion in the meter. The output of the meter is picked up from the rotation of the blocking rotor and transmitted to a register or pulse transmitter.

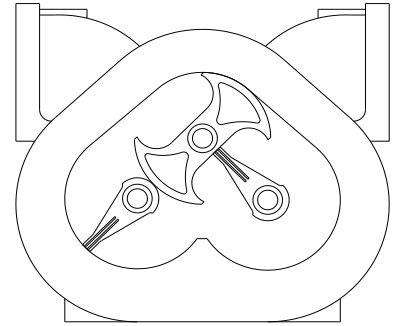

The rotors in the meter are designed to operate at close tolerances to one another and the wall of the fluid chamber. There are slight clearances between the rotors and the chamber wall. Because of this, it is important that the meter be properly applied for the flow rate and operating pressure of the system.

Because the fluid flowing through the meter is redirected only slightly from its natural flow, there is very little pressure drop across the meter, unlike other meters that use multiple measuring chambers.

The meter design uses high performance materials for the rotor bearings and journals. Since there is no contact between the rotors and the fluid chamber wall, these critical components have a long life expectancy.

Calibration of the meter involves adjusting the rotation of the output shaft relative to the rotation of the internal rotors of the meter. This is accomplished by changing the settings on an adjuster device. Calibration of the meter is discussed in detail in the section Meter Calibration.

## Meter Specifications & Materials of Construction

Flange Connection:	2" NPT Flanges, Standard; 1-1/2" NPT Flanges, Optional. BSPT or Slip Weld flanges available upon request.
Flow Rate:	100 GPM (380 LPM), max flow
Maximum Pressure:	350 PSI (24 BAR)
Working Temperature:	-40 F to 122 F (-40 C to 50 C)
Materials of Construction:	Housing & Rotors: Hardcoat Anodized Aluminum; Bearing Plates: Ni-Resist II; Bearings: Carbon Graphite; Gears: Stainless Steel; Seals: UL recognized Buna-N

### FLOW ILLUSTRATION

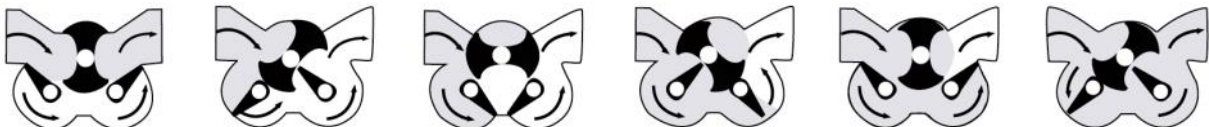

## Procedures for LPG Meters

This manual provides warnings intended to inform the owner/operator of the hazards present with this type of equipment. Knowledge of these warnings and avoidance of potential hazards is the sole responsibility of the owner/operator of the equipment. Neglect of that responsibility is not within the control of the manufacturer of this equipment, and the manufacturer bears no responsibility for damages, injuries or deaths resulting from improper or inappropriate use or servicing of the equipment.



**All internal pressures must be relieved (to zero psi) before inspection, disassembly, or servicing of any part of this meter or metering system. Property damage and serious injury or death from fire or explosion could result from improper use of this equipment, or from maintenance of an improperly depressurized and evacuated meter and metering system. Always follow all federal, state, and local laws, ordinances, and industry codes when installing, operating, or servicing this equipment.**

### Procedure for Relieving Pressure in LPG Meters

NOTE: All procedures to depressurize and purge an LPG tank system must be performed out-of-doors in an open environment free from any ignition sources such as sparks, flames, or heat sources.

1. Close the belly valve of the supply tank.
2. Close the valve on the vapor return line.
3. Close the manual valve in the supply line on the inlet side of the meter. If no manual valve exists on the inlet side, consult the system manufacturer for procedures to depressurize the system.
4. Slowly open the valve/nozzle at the end of the supply line
5. After product is bled off, close the valve/nozzle at the end of the supply line.
6. Slowly crack the fitting on top of the differential valve to relieve the product pressure in the system. Product will drain from the meter system.
7. As product is bleeding from the differential valve, slowly reopen and close the valve/nozzle on the discharge line. Repeat this step until the product stops draining from the differential valve and discharge line valve/nozzle.
8. Leave the discharge line valve/nozzle open while working on the system.



## System Recommendations



### Meter Selection

The flow meter must be carefully chosen from the Meter Selection factors in the Engineering Manual. The meter must be selected based on the operating system and product characteristics. System variables include flow rate, temperature and pressure. Failure to select the correct flow meter may result in system failure or serious injury.

### Vapor Elimination

In any system where the tank may be completely drained or multiple products manifold into one metering system, the possibility of vapor being present increases. The solution is an air or vapor eliminator located before the flow meter to vent the vapor from the system before it can be measured. Vapor elimination is required for all weights and measures regulatory approvals in custody transfer applications.

### Control Valves

Safety and isolation valves should be used throughout the metering system. Differential Valves should be used to prevent vapor from entering the liquid flow meter (Vapor Eliminator required).

### Best Plumbing Configuration

The flow meter must have a secure mounting to a riser or foundation, with the inlet and outlet piping securely supported to prevent any pipe stress on the flow meter. The system should be designed to keep the flow meter full of liquid at all times. Use full 2" pipe diameter throughout the metering system to allow for minimum pressure loss. The piping should be designed to prevent draining of the flow meter. The meter inlet and outlet should be lower than the system plumbing (sump position). The metering system should include a means for calibration.

### Protection From Debris

On new installations, care must be taken to protect the meter from damage during start-up. It is recommended to put a strainer before the meter. Damage may result from the passage through the meter of dirt, sand, welding slag or spatter, thread cuttings, rust, etc. A spool can be fabricated and installed in place of the meter until the system is flushed. A spool is a flanged length of pipe equal in length to the meter and any accessories attached to the meter) such as a vapor eliminator or control valve. Another method is to temporarily bypass the plumbing containing the meter until the system is flushed. This will also protect the meter from debris. Once the system has run "clean" for a period of time the meter may be reinstalled or protective means removed.

### Thermal Expansion

Most liquids will expand and contract with temperature. This is particularly true for LPG. In any system where there is a chance for liquid to be captured between closed valves without relief, thermal expansion will likely occur. This can create dangerously high pressures within the system. Care should be taken in designing the system in which thermal shock may occur by implementing Pressure Relief Valves or Thermal Expansion Joints in the system design.

### Hydraulic Shock (Water Hammer)

Hydraulic shock is a rise in pressure, which happens when an operating system undergoes an immediate change in flow direction. This is most often the result of a rapid valve closure while the system is operating at a high flow rate. Hydraulic shock can damage any system component. Particularly susceptible are internal components of the meter, valves and pump. System design and improper operating procedures will contribute to the seriousness of this problem. In order to eliminate hydraulic shock, the valve closure rate must be slowed. The use of 2-stage preset control valves or surge suppressing bladders or risers will help reduce or eliminate this problem.

### Calibration

The meter shall be tested and calibrated with the product it is intended to measure when installed. Total Control Systems shall not be responsible for loss of product or any damages resulting from the end user's failure to test this meter to insure proper calibration. Every 700 Series meter is tested and calibrated at the factory to prove that the meter can be calibrated in your system. It is the owner's responsibility to report this device to the local Weights and Measures officials for their inspection before the meter is put to use.



## Start up Recommendations



### ***!WARNING!***

Test equipment should be grounded to prevent a possible spark. Test area should have no ignition source. Operators should wear personal protection and prevent any product exposure and environmental issues.

Start-up instruction for new installations or after maintenance and repairs:

- 1) Only properly trained personal should design, install, or operate metering system.
- 2) Remove plastic threaded plugs placed in meter for shipping protection. They are not to be used in meter system because of the PVC plugs low rated pressure, compatibility, and sealing issues.
- 3) Place the meter in an area with ample workspace, secure from vibration, and pipe line stress. Mount and bolt down on to a fixed stand or platform. This prevents meter stress, which will cause leakage and metal fatigue.
- 4) Apply thread sealing compound and gasket materials that are compatible with product.
- 5) Do not weld to the meter or accessories. This will weaken housings, cause O-ring and casting leaks and potentially distort the critical tolerances within the flow meter.
- 6) Always wear safety protection equipment such as goggles, steel toed shoes, gloves and full body clothing.
- 7) Be sure to install a pressure relief valve or expansion joint in the system to protect against thermal expansion.
- 8) Make sure all system components and meter assembly bolts are properly secured and tightened.
- 9) Make sure the vapor eliminator vapor release is properly vented and piped back to the supply tank.
- 10) Make sure electrical connections are properly installed and start/stop switches are off and locked-out.
- 11) Ensure that there is flooded suction to the pump and that the fluid is available to the system to prevent the starving or cavitation of the pump.
- 12) Ensure slow flooding of system. **Start up system with all shut off valves in the closed position.** When a pump is turned on and a valve opened in a new, dry system, tremendous liquid and air pressure can be built up in the piping and forced through the meter. The high pressure and volume of air causes the meter to rotate more rapidly than normal. When the fluid product reaches the meter, there is an abrupt slowing of the meter rotors. This can cause damage to the register, rotor shafts, packing gear and/or blade, timing gears and other components.  
*The recommended method of starting any system is to flood the piping gradually. This allows product to slowly force the air or vapor from the entire system.*
- 13) When operating the meter with accessories, valves should be opened slowly to avoid a pressure surge that can damage the meter or air eliminator. System pressures should be maintained below 350 PSI (24 BAR).
- 14) Custody transfer metering systems must be calibrated by a regulatory agency before product can be sold off the meter. Contact your local authorities for proper calibration.
- 15) Strainers should be cleaned frequently or have a maintenance schedule. This will ensure a clean system and long service life.

## Direction of Flow

The meter is set up at the factory for left to right flow. To change the meter for right to left flow, begin by removing the screws (#9 on the Meter Assembly Breakdown) and the adjuster cover plate (#7) on the front of the meter. Remove both the screws (#1), the drive shaft retainer (#10), the drive shaft (#3), the e-ring (#4) and the face gear (#5). Reinstall the gear on the shaft with the gear teeth facing up. Snap the e-ring back into place to hold the gear in place. Reinstall the shaft, mating the face gear with the drive gear of the packing capsule assembly. Reinstall the screw and cover plate. The meter will now be set up for right to left flow. See Page 16 for a parts breakdown of entire meter assembly.

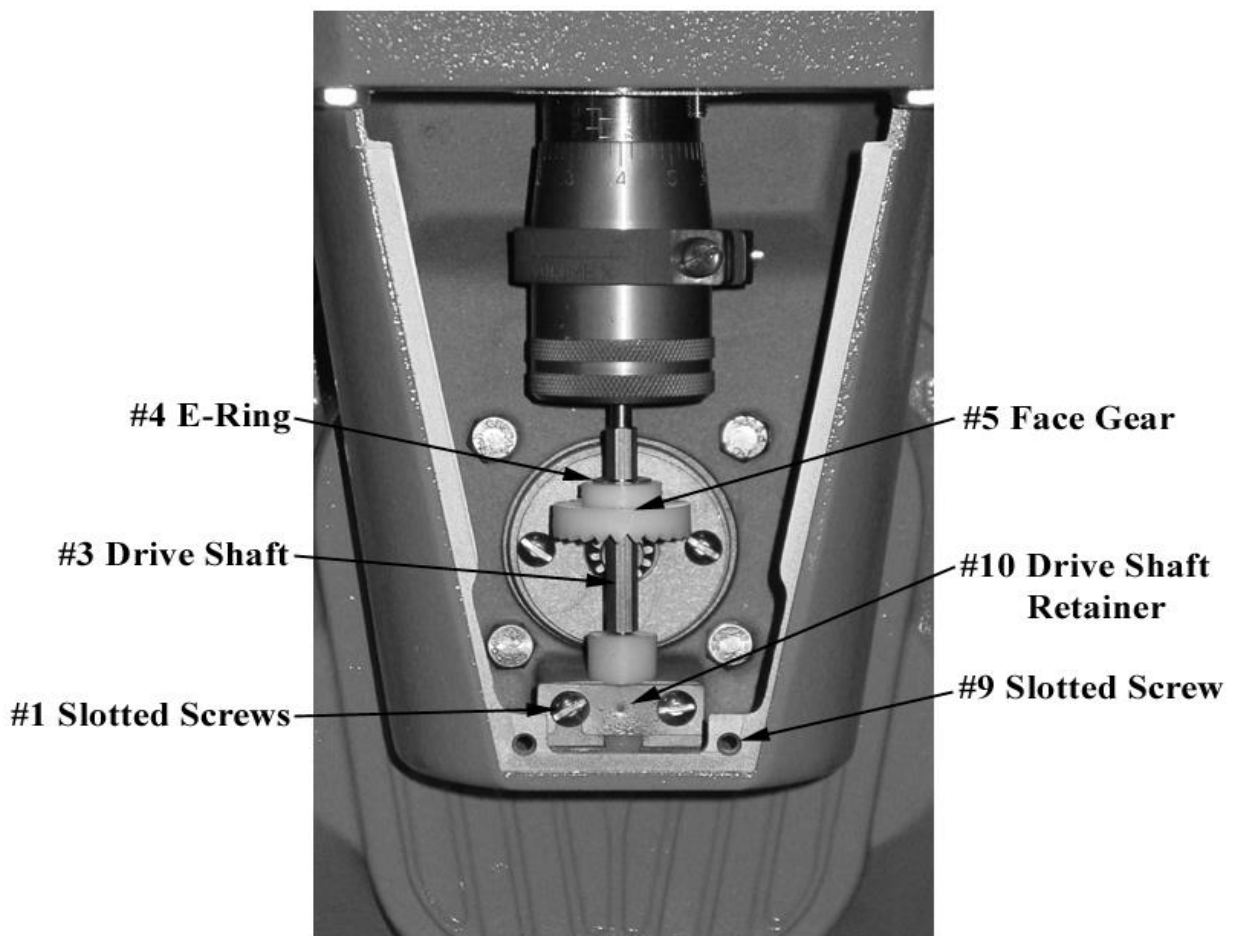

## Meter Calibration



The method of proving should be selected, and necessary provisions made, during the design stage of the installation. Use only an accurate, specifically and scientifically designed prover. No other kind should be used. All provers should be checked periodically for accuracy. Weights and Measures officials have been very cooperative in giving assistance in checking provers.

### Use an Accurate Prover

Scientifically designed provers are commercially available for proving meters, and no other kind should be used. In addition, since LPG systems are closed systems, a specially designed prover is a must for proving meters for LPG.

Scientifically designed test measures have proper drainage means built into them, a calibration gauge glass neck and protection against deformation (which would cause volume changes).

Scientifically designed provers are not merely truck compartments or drums. A “homemade” prover, whether a drum or a tank is not likely to be satisfactory, and may cause expensive errors due to inaccurate meter calibration.

Even scientifically designed provers should be checked periodically for accuracy. Weights and Measures officials have been very cooperative in giving assistance to checking privately owned volumetric provers.

A detailed description of LP Gas test procedures may be found in the NCWM Course 305 “Liquefied Petroleum Gas Liquid Measuring Devices”.

### Recommended size of test measure

The prover capacity should be equal to at least one minute’s flow through the meter at its maximum rate.

### Setting the Prover

The prover should be set level, using the levels provided on the prover, or separate leveling means. This insures consistent results when moving the prover from meter to meter and provides the basis for accurate readings on the prover scale.

### Where to Test a Meter

The best place to test a meter is in its normal operating position, instead of a test stand. In this way, the correctness of the installation and of the operating conditions of the system will be verified by the test. Always test a meter with the same liquid it is to measure. Even slight differences in viscosity, temperature or system plumbing can have a significant effect on meter accuracy.

### Discharge Line from Meter

Where a portable prover is used, the liquid is generally discharged into the prover in the same manner as a normal delivery would be made (with a hose reel and LPG fitting, for example). Where a special delivery test connection is used, the discharge line must be arranged to drain to the same point on each test. The meter flow rate and start and stop must be controlled at the end of the discharge line.

### Wetting the Prover

Reset the meter register to zero, and fill the prover to the zero line or 100% marking of the scale. Disregard this meter reading. Drain the prover and reset the register. The reason for disregarding the first meter reading is that the prover must be wetted. The calibrated capacity of the prover has been determined by its manufacturer based its wet measure capacity. Once wetted, the prover will be wet for all the subsequent tests to be run.

## Meter Calibration (Continued)



Always empty the prover with the same procedure. You must ensure that the prover is completely empty prior to closing the dump valve. This time interval must be the same for each test to ensure uniform results. If a considerable length of time is to elapse between tests (lunch break or phone call), the wetting operation can be eliminated by allowing the prover to remain full until the next test is to be run.

### Making the Tests

The setup is now ready for accuracy the test. Reset the register to zero, and run the required test quantity through the meter. Do not exceed the maximum recommended rate of flow for the meter. Maximum and minimum recommended rates of flow for various sizes and types of 700 series meters are marked on the flow meter's identification plate and in the maintenance manuals.

### Determining Test Results

Run the meter close to the mark on the indicator corresponding to the full prover capacity. Read the over or under delivery in cubic inches, gallons or percent on the calibrated plate on the neck of the prover. If the plate is calibrated in cubic inches, the percentage error can readily be computed on the following basis:

**One gallon is equal to 231 cu.in.**

Example: A 100-gallon prover holds 23,100 cu.in. Therefore, 23.1 cu.in. represents 0.1% error.

### Meter Tolerance

In the United States, the National Institute of Standards and Technology, in NIST Handbook 44, plus or minus tolerances are according to the following:

Indication of Device	Tolerance			
	Acceptance Test	Maintenance Test	Special Test	Repeatability
Wholesale or Vehicle	0.6%	1.0%	1.0%	0.40%

In Europe, plus or minus tolerances are specified by OIML R117-1. In Canada, the plus or minus tolerances are specified by the National Measurement Act.

Indication of Device	Tolerance			
	Acceptance Test	Maintenance Test	Special Test	Repeatability
Europe	0.6%	1.0%	N/A	0.40%
Canada	0.6%	1.0%	N/A	0.40%

Acceptance tolerances apply to new meters and repaired meters after reconditioning. Maintenance tolerances apply to meters already in service. Special tolerances apply to meters in the United States only, for special instances as determined by weights and measures officials.

### Changing Meter Calibration

Refer to meter literature for method of changing meter calibration. Any change in the meter calibration adjustment will change the delivery in the same amount for all rates of flow. That is, the calibration curve retains its shape, but is moved up or down. Therefore, if a meter tests satisfactorily at full flow, but drops off too much at low flow, changing the calibration will not remedy this condition; it will bring the low flow test to 100%, but it will also bring the full flow above 100% by the same amount that the low flow was raised. A condition of this kind is caused either by the metering system, need for meter cleaning or repairs, or because of an attempt to retain accuracy below the minimum recommended rate of flow for the meter.

## Meter Calibration (Continued)



### Repeatability

Consider the percentage error readings from each test run made at the same flow rate and draft size (calibration run). The difference between the reading with the highest value and that with the lowest value must be less than a value which is 40% of the applicable maintenance tolerance. For example, a meter in the USA, this would be 0.12% ( $0.30\% \times 0.4 = 0.12\%$ ). The percentage error of all test runs at each flow rate must still be within the applicable tolerance.

### Temperature Correction

If the conditions of testing are such that there will be a change of more than a few degrees in the temperature of the liquid between the time it passes through the meter and the time the prover is read, it will be advisable to make a temperature correction to the prover readings. To do this, it is necessary to install thermowells in the system, to take readings of the temperature of the liquid at the meter and in the prover. Corrections can then be easily made by the use of the National Standard API Tables.

## Calibration Adjustment

One complete turn of the adjuster barrel is equal to 1 gallon in 100 gallons or 1% of delivered volume. The adjuster body will show divisions of 1%, while the adjuster barrel has divisions of 0.02%. For volumes other than 100 gallons, the following formula may be used to calculate the Adjuster percent to increase or decrease prover volume.

$$\% \text{ Correction} = \frac{\text{Prover Volume} - \text{Meter Volume}}{\text{Prover Volume}} \times 100$$

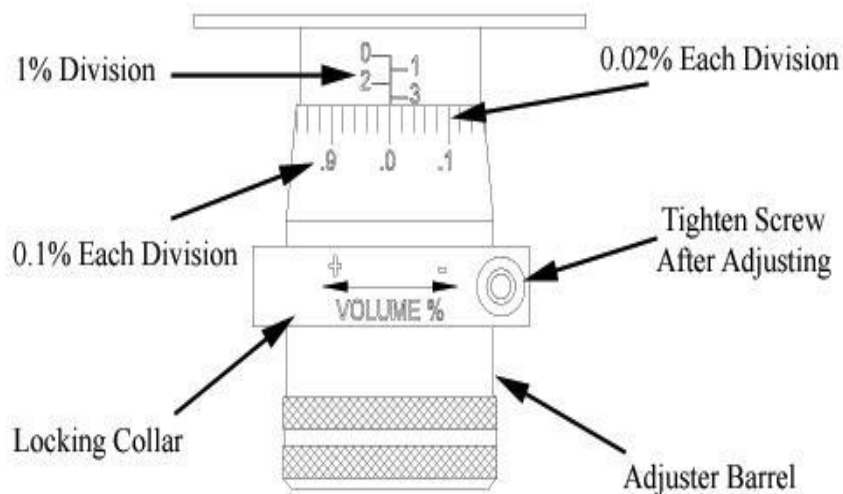

## Maintenance



### ***!WARNING!***

Test equipment should be grounded to prevent a possible spark. Test area should have no ignition source. Operators should wear personal protection and prevent any product exposure and environmental issues.

- 1). Keeping accurate maintenance and calibration records can be an excellent tool in determining the frequency of inspection or maintenance for a system. As the meter wears, the calibration will be affected and require adjustment. A personality profile can be created for each meter to help guide in a maintenance schedule.
- 2). Great care should be utilized in the maintenance of the metering system. Personal safety protection, environmental hazards, and government regulations need to be the foremost priority. Only fully trained personnel should be involved in maintenance. Failure to use original TCS replacement parts will void any Weights & Measures approvals and risk damage to the meter system.
- 3). ALWAYS RELIEVE INTERNAL SYSTEM PRESSURE TO ZERO BEFORE DISASSEMBLY OR INSPECTION.
- 4). SERIOUS INJURY OR DEATH FROM FIRE OR EXPLOSION COULD RESULT FROM MAINTENANCE OF AN IMPROPERLY DEPRESSURIZED AND EVACUATED SYSTEM.
- 5). Total Control Systems flow meters and accessories are often used with LPG, petroleum, solvents, chemicals, and other liquids that may be explosive, extremely flammable, very toxic, oxidizing, and corrosive. Severe injury or fatalities may result if appropriate safety precautions are not followed.
- 6). Before replacing or cleaning filter/strainer screen, the electrical system must be turned off. Product needs to be drained from system. Collect all product and return to storage or dispose of properly. Replace all drain plugs that were removed. Personal safety protection must be worn at this time. Make sure there is adequate ventilation in the area. The metering system will not completely drain so make sure you collect extra product when you remove the strainer cover. Clean the screen once a week, or more often if there is a lot of sediment in the system. Make sure there is no ignition source and the system is grounded. Replace all plugs that were removed for drainage.
- 7). The metering system is heavy and awkward so take precaution to handle it properly.
- 8). Do not use force to disassemble or use a screwdriver to pry open any part of the metering system. Have the proper tools available before trying to repair the meter system. Use caution when handling the internal parts as they can be sharp and heavy. Do not drop housing or rotors as they can cause injury and can be damaged or destroyed. Use caution when inspecting and aligning the timing gears and rotors as they can pinch fingers. Turn these slowly to verify smooth operation.
- 9). When inspecting the spring loaded preset valves do not place anything inside the housing, as the action of the valve will pinch this object when the valve closes.

## Maintenance (Continued)



### ***!WARNING!***

Test equipment should be grounded to prevent a possible spark. Test area should have no ignition source. Operators should wear personal protection and prevent any product exposure and environmental issues.

- 10). When removing gaskets or O-rings, carefully check for damage or corrosion. Any cracked, rough, worn, elongated or swollen O-rings must be replaced. When replacing the O-rings, place grease along the inside of the O-ring groove or completely around the O-ring to help the O-ring stay in the O-ring groove during assembly. If an O-ring is pinched or not in the O-ring groove, the meter system will leak and cause serious problems to the environment and equipment. Collect all replaced parts and dispose of properly. Do not weld any part of the meter system or accessories as this will weaken the part and allow for leaks.
- 11). All bolts and screws must be coated with Anti-Seize lubricant. Follow the torque specifications for each flow meter, air eliminator, strainer or preset valve bolt found on pages 23 and 24.
- 12). Recommended levels of maintenance and inspection will depend upon the system variables, such as the characteristics of the products being measured (viscosity, corrosiveness, suspensions, etc.), system pressure requirements, government or company regulations, and the age of the metering system. If hydrostatic testing is required, the system pressure should not exceed 1.5 times the marked meter pressure. It is not recommended to pneumatically test the meter system at anytime.
- 13). If any component of the meter system is removed from the system, it should be thoroughly flushed with a compatible liquid. After this is done, immediately refill the meter or accessory with a compatible liquid to prevent corrosion and water build up.

## Storage Instructions



Short periods of non-use of the meter (a week or less) should present no problem, provided that the meter remains full of product. For long periods of non-use, such as winter storage, the following procedure is recommended. Before long-term storage, it is recommended that the meter be calibrated to verify that it is functioning properly.

- 1). To store the meter when it is left in line, flush the system with clean water until 70-80 gallons of water have passed through the meter.
- 2). Pump a 50% anti-freeze / 50% water solution through the entire system (100% RV antifreeze may be used instead). With the pump running, shut off a valve downstream from the meter, making sure that the system is full of anti-freeze solution to that point. Then close an upstream valve, such that the meter remains full of anti-freeze solution.
- 3). Remove the register from the meter, and lubricate the drive coupling shaft. After lubrication, reassemble the register onto the meter.

When starting the system after a period of storage, it is recommended that the meter calibration be rechecked.



# 700-20LP Meter Assembly

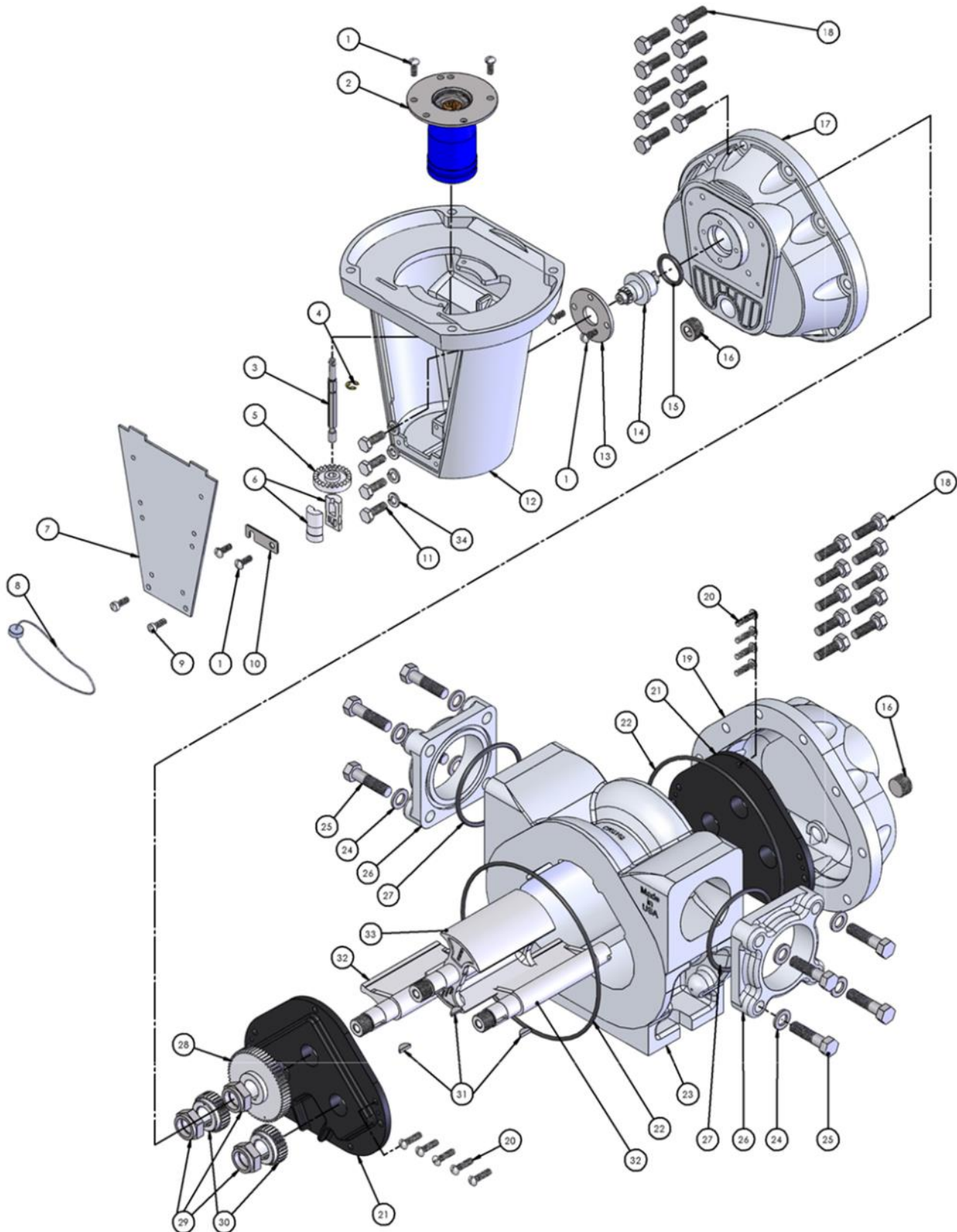

## 700-20LP Meter Assembly

Item	Description	Qty	700-20-LP
1	10-24 x 1/2 Slotted Screw	8	1-128279
2	Adjuster Assembly	1	700100
3	Drive Shaft	1	700019
4	E-Ring	1	700016
5	Face Gear 24T	1	700018
6	Drive Bushing	2	700020
7	Register Support Cover	1	700017
8	Seal Wire and Seal	1	1-118849
9	10-24 Slotted Drilled Machine Screw	2	700042D
10	Drive Shaft Retainer	1	700022
11	1/4-20 x 3/4 Hex Head Bolt	4	700040
12	Register Support	1	700200
13	Packing Retaining Plate	1	700015
14	Packing Capsule	1	700180
15	O-Ring (Buna)	1	700049
16	3/8" Plug	2	700064
17	Front Cover	1	702505
18A	5/16-18 x 1 Grade 8 Bolt	16	702027
18B	5/16-18 x 1 Grade 8 Bolt, Drilled	4	702027D
19	Rear Cover Assembly	1	702575
20	10-24 x 3/4 Slotted Screw	10	702014
21	Bearing Plate w/ Carbon Graphite Bearings	2	702225
22	Cover Gasket	2	702028
23	LP Meter Housing Assembly	1	702115
24	Special Spacer	8	702018
25A	3/8-16 x 1-1/2 Grade 8 Bolt	4	702026
25B	3/8-16 x 1-1/2 Grade 8 Bolt, Drilled	4	702026D
26A	2" NPT Steel Flange	2	702613
26B	2" BSPT Steel Falnge	2	702621
27	2" Flange Quad Ring	2	702025
28	Blocking Rotor Gear Sintered	1	702351
29	Rotor Lock Nut	3	702010
30	Displacement Rotor Gear Sintered	2	702451
31	Rotor Key	3	702008
32	Displacement Rotor Assembly	2	702405
33	Blocking Rotor Assembly	1	702305
34	1/4" Split Lockwasher	4	700071

Murray Equipment, Inc.

Check us out at [www.TCSmeters.com!](http://www.TCSmeters.com!)

# 740-20LP Vapor Eliminator & Strainer Assembly

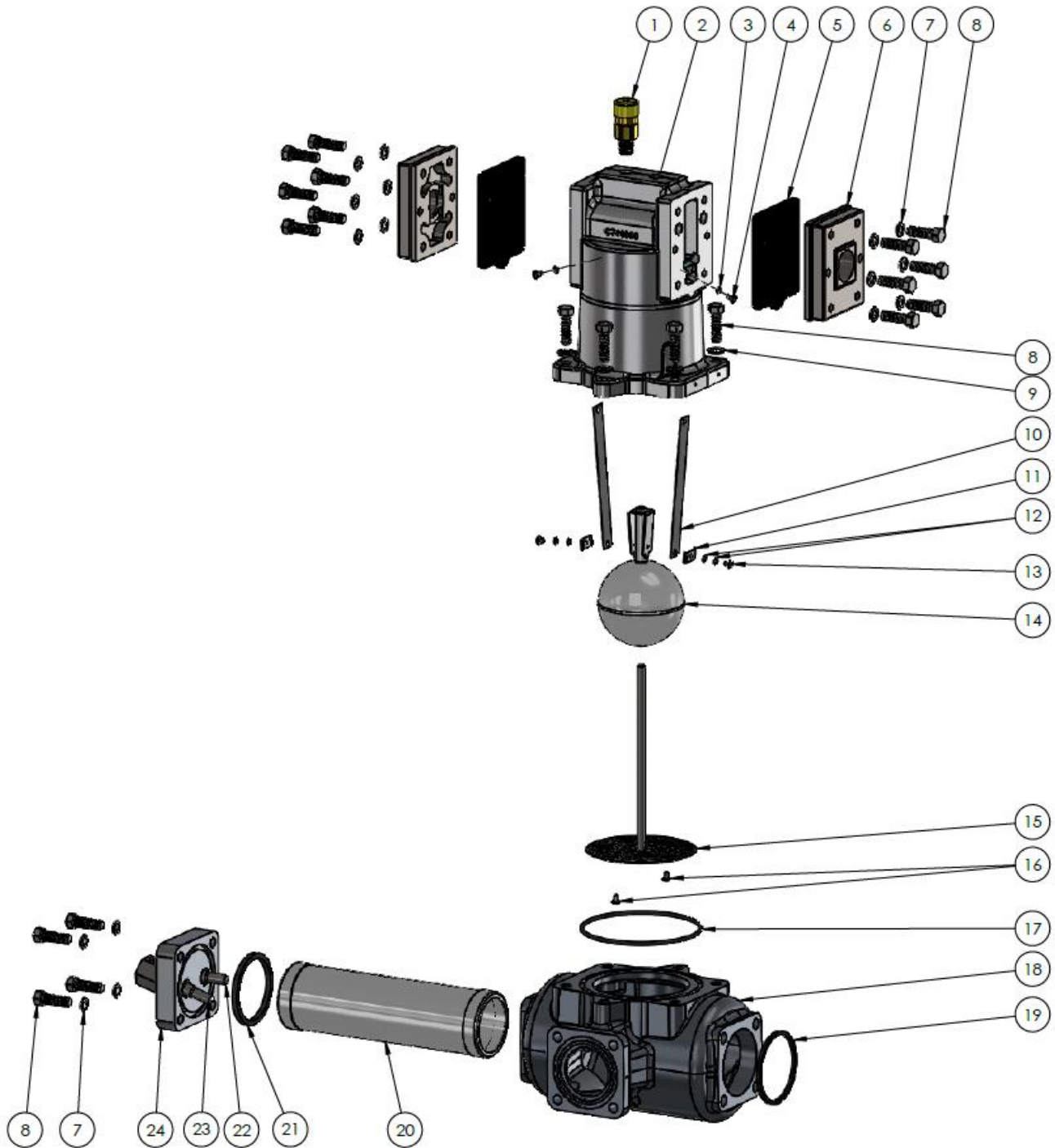

## 740-20LP Vapor Eliminator & Strainer Assembly

Item	Description	Qty	700-740-20-LP
1	1/4" Hydro Relief Valve	1	740110
2	LPG Air Eliminator Housing	1	740060
3	# 8 Split Lockwasher	2	740017
4	8-32 x 1/4 Phillip Pan Head	2	740030
5	Valve Plate, Nitrite	2	740206
6A	3/4" NPT Outlet Cover, LPG	2	740115
6B	3/4" BSPT Outlet Cover; LPG	2	740116
7	Ring Washer SM OD	12	740051
8A	5/16-18 x 1-1/2 Grade 8 Bolt	10	740056
8B	5/16-18 x 1-1/2 Grade 8 Bolt, Drilled	2	740056D
9	Special Spacer	6	702018
10	Reed Vapor Eliminator	2	740007
11	Retaining Clip	2	740012
12	# 8 Split Lockwasher	4	740017
13	8-32 x 1/4 Phillip Pan Head	2	740030
14	Float and Stop Assembly	1	740034
15	Diffuser/Shaft Assembly	1	740035
16	8-32 x 1/4 Phillip Pan Head	2	740030
17	Top Seal (Buna)	1	740053
18	Aluminum Strainer Housing	1	742081
19	Flange Quad Ring	1	702025
20	Strainer Basket 100 Mesh	1	742025
21	Seal Ring (Buna)	1	742024
22A	1/2" NPT x 2" Aluminum Temperature Thermowell	1	740300
22B	1/2" NPT x 2" Stainless Steel Temperature Thermowell	1	740400
23A	3/8" NPT x 2" Aluminum Temperature Reference Port	1	740305
23B	3/8" NPT x 2" Stainless Steel Temperature Reference Port	1	740405
24	ATC Basket Cover	1	742355

Murray Equipment, Inc.

Check us out at [www.TCSmeters.com](http://www.TCSmeters.com)!

# 757-20LP Differential Valve Assembly

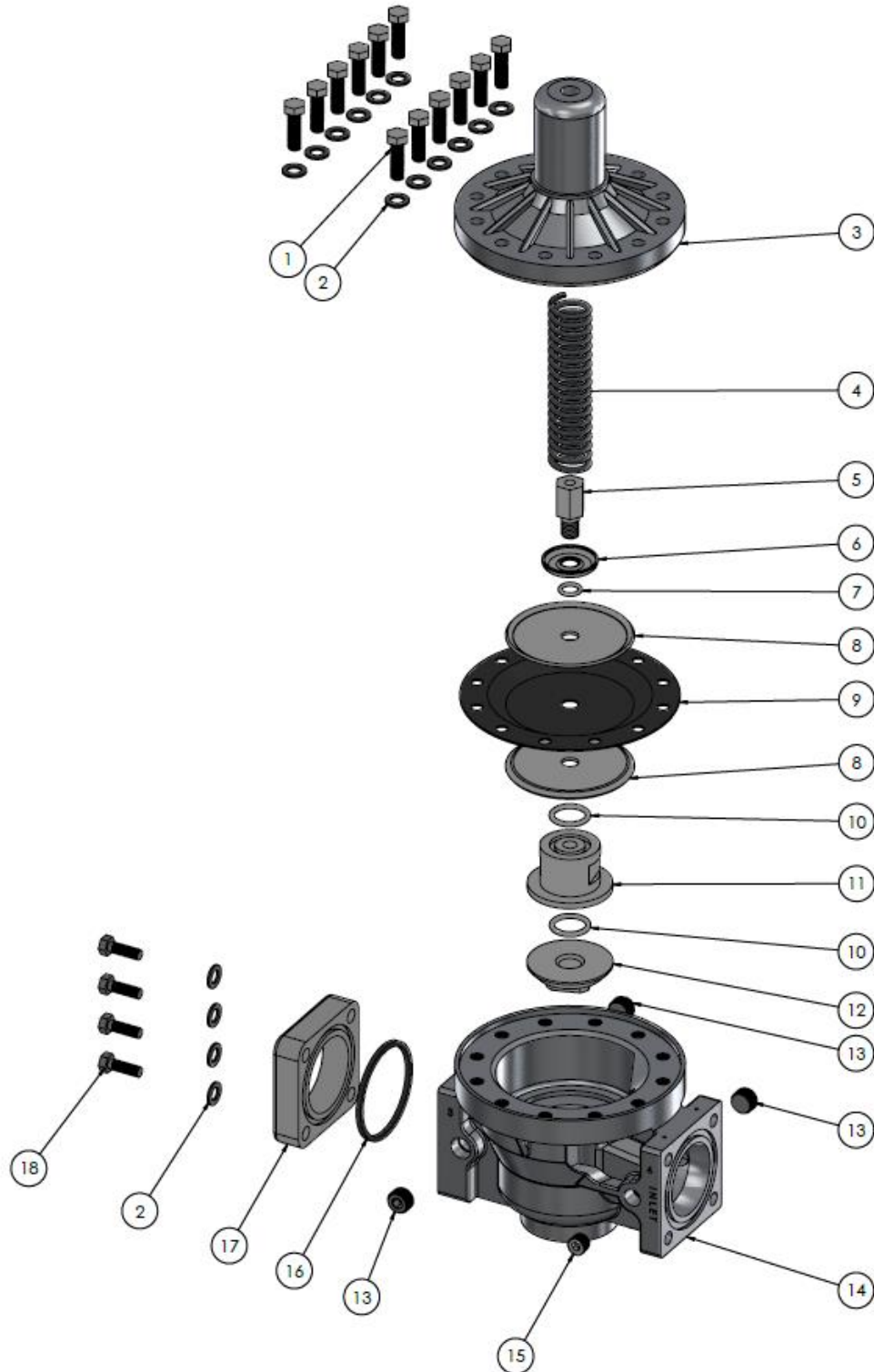

## 757-20LP Differential Valve Assembly

Item	Description	Qty	700-757-20LP
1	Screw	12	700063
2	Spacer	16	702018
3	Valve Cap	1	757035
4	Valve Spring	1	757055
5	Diaphragm Adapter	1	757010
6	Spring Retainer	1	757005
7	O-ring Seal	1	757025
8	Diaphragm Back Plate	2	757001
9	Diaphragm	1	757040
10	O-ring Seal	2	757020
11	Diaphragm Poppet	1	757030
12	Seat; Delrin	1	757015
13	Socket Plug; 3/8" NPT	3	700064
14	Valve Housing	1	757110
15	Hex Plug; 1/4" NPT	1	757075
16	Quad Ring; Flange	1	702025
17A	2" NPTSteel Flange	1	702613
17B	2" BSPTSteel Flange	1	702621
18	Screw	4	700026

# 782-20LP In-Line Check Assembly

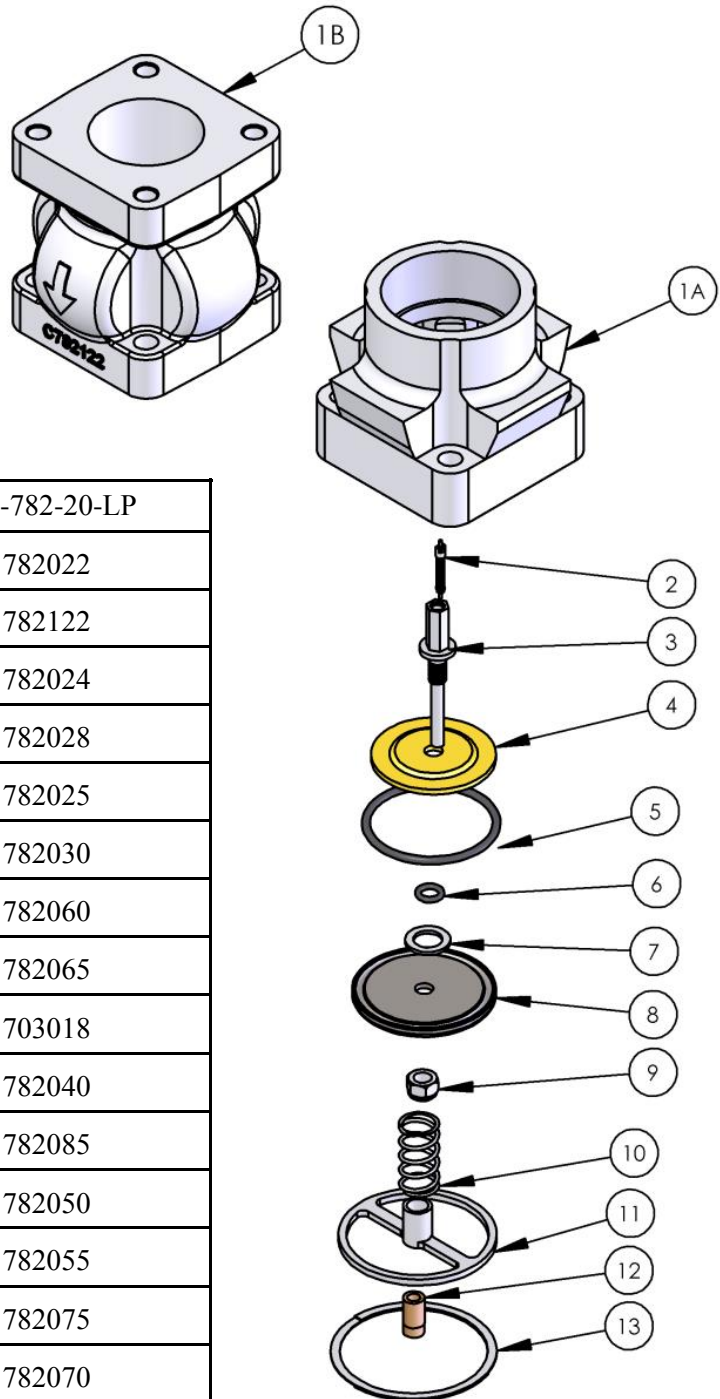

Item	Description	Qty	700-782-20-LP
1A	Housing , 2" NPT	1	782022
1B	Housing, Flanged		782122
1C	Housing, 2" BSPT	1	782024
2	Pressure Relief Valve	1	782028
3	Valve Stem	1	782025
4	Piston Ring	1	782030
5	O-ring Main Seal	1	782060
6	O-ring	1	782065
7	Special Spacer	1	703018
8	O-ring Retainer	1	782040
9	5/16-18 Nylock Nut	1	782085
10	Spring	1	782050
11	Spring Holder	1	782055
12	Bearing Sleeve	1	782075
13	Retaining Ring	1	782070



## Torque Specifications

### 700-20LP METER ASSEMBLY

Part Number & Description	Tool	Bolt Size & Material	Foot Lbs. (+/- 10%)		Newton Meter (+/- 10%)	
			Dry	Lubricated	Dry	Lubricated
Cover Screws	1/2" hex wrench/socket	TCS 702027 5/16-18 SAE Grade 8	29	23	39	31
Counter Support Screws	7/16" hex wrench/socket	TCS 700040 1/4-20 18-8 SS	6.3	5.0	8.5	6.8
Bearing Plate Screws	slotted screwdriver	TCS 702014 10-24 316 SS	1.9	1.5	2.6	2.0
Dust Cover Screws	slotted screwdriver	TCS 700042D 10-24 18-8 SS	1.9	1.5	2.6	2.0
Rotor Gear Nut	15/16" hex wrench/socket	TCS 702010 5/8-18 316 SS	31	25	42	34

### 740-20-LP VAPOR ELIMINATOR/STRAINER ASSEMBLY

Part Number & Description	Tool	Bolt Size & Material	Foot Lbs. (+/- 10%)		Newton Meter (+/- 10%)	
			Dry	Lubricated	Dry	Lubricated
Cover Plate Screws	1/2" hex wrench/socket	TCS 740056 5/16-18 SAE Grade 8	20	16	27	22
Cap Screws	9/16" hex wrench/socket	TCS 700063 3/8-16 SAE Grade 8	36	29	49	39
Reed Screws	Phillips screwdriver	TCS 740030 8-32 316 SS	1.8	1.4	2.4	1.9
Diffuser Screws	Phillips screwdriver	TCS 740030 8-32 316 SS	1.8	1.4	2.4	1.9
Basket Cover	9/16" hex wrench/socket	TCS 702026 3/8-16 SAE Grade 8	36	29	49	39

## Torque Specifications (Continued)

### 757-20-LP DIFFERENTIAL VALVE ASSEMBLY

Part Number & Description	Tool	Bolt Size & Material	Foot Lbs. (+/- 10%)		Newton Meter (+/- 10%)	
			Dry	Lubricated	Dry	Lubricated
Cap Screws	9/16" hex wrench/socket	TCS 700063 3/8-16 SAE Grade 8	36	29	49	39
Diaphragm Adapter	3/4" hex wrench	TCS 757010 1/2-13 Steel	21	17	28	23
Valve Seat	1-1/4" Hex wrench	TCS 757015 3/4-16 Delrin	21	17	28	23
Valve Plug	5/16" Allen wrench	TCS 757075 3/8"-NPT Forged Steel	<ol style="list-style-type: none"> <li>1. Lubricate with Loctite 567</li> <li>2. Tighten by hand</li> <li>3. Tighten 1-1/2 to 2 turns with wrench</li> </ol>			

### 782-20-LP IN-LINE CHECK VALVE ASSEMBLY

Part Number & Description	Tool	Bolt Size & Material	Foot Lbs. (+/- 10%)		Newton Meter (+/- 10%)	
			Dry	Lubricated	Dry	Lubricated
Cover Plate Screws	1/2" hex wrench/socket	TCS 740056 5/16-18 SAE Grade 8	20	16	27	22

## Meter Dimensions in Inches (Millimeters)

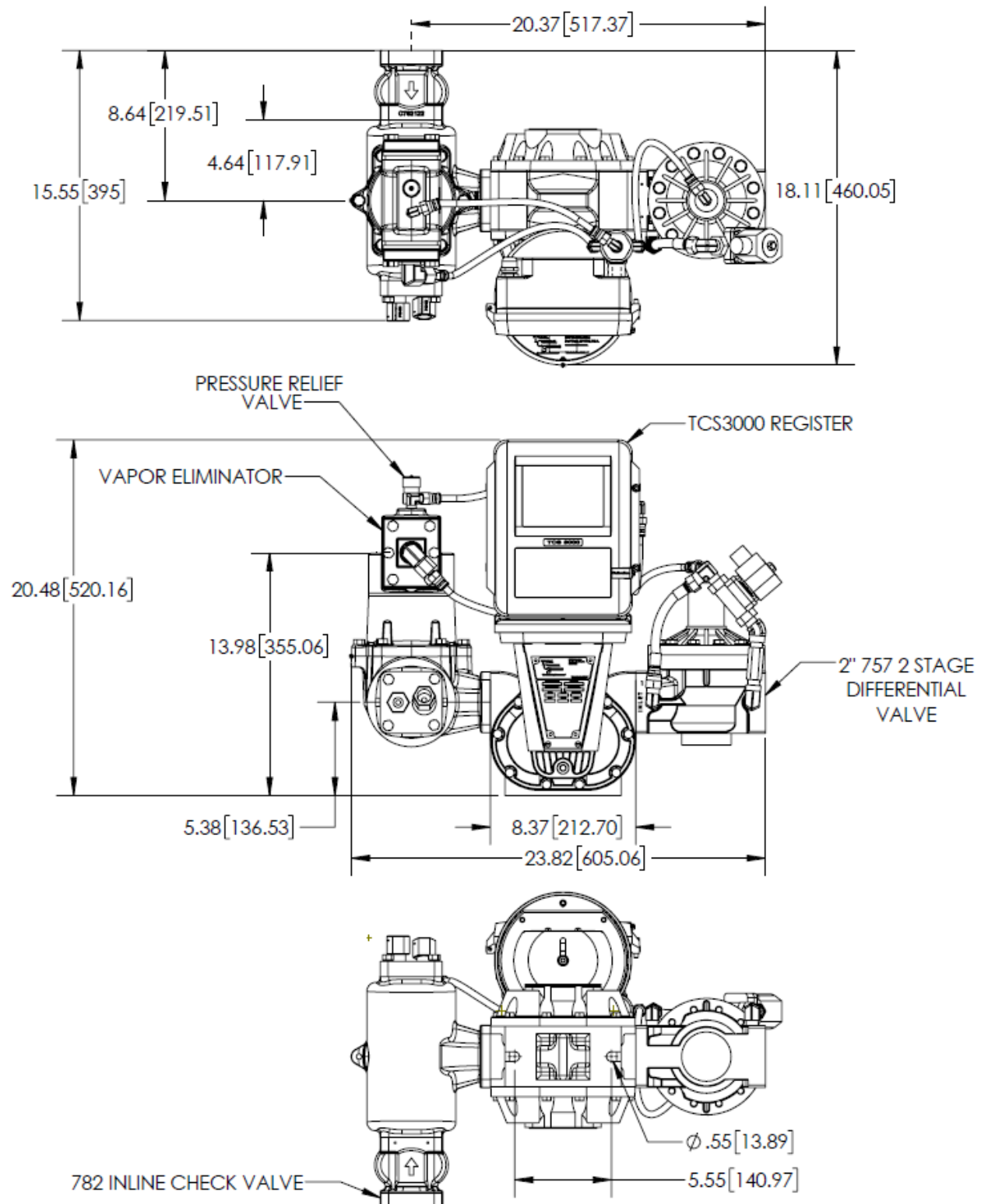

# Drive Components



## Removing the Dust Cover

- 1) Cut dust cover seal. Remove the dust cover screws with a standard flathead screwdriver.
- 2) Note the setting on calibration adjuster.
- 3) Note the position of the drive gear (either above or below the packing gland pinion).

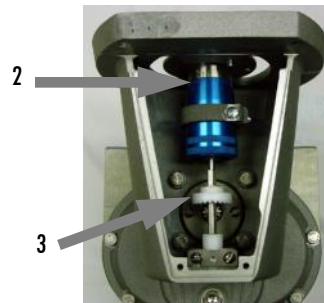
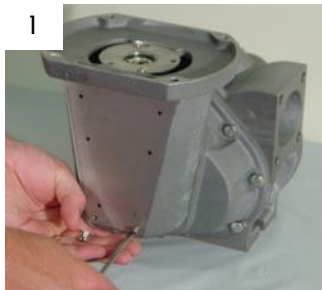

## Removing the Adjuster

- 1) Loosen the retaining screws using a standard flathead screwdriver.
- 2) Slide the retaining clip up and over to the right side.



- 3) From the top, remove the screws to adjuster plate.
- 4) Lift adjuster out of the counter adapter.
- 5) Remove the adjuster drive assembly.

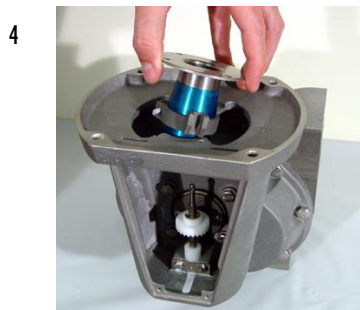

## Disassembly of Meter



### ***!WARNING!***

All internal pressure must be relieved to ZERO (0) pressure before beginning disassembly of meter or components

### Draining Meter & Removing Counter Support

- 1) Drain the meter by turning it on either the inlet or outlet side.
- 2) Remove the counter bracket screws with a hex wrench or socket driver.
- 3) Remove the drain plugs on the front and rear covers using an allen wrench. Allow more fluid to drain from the meter.

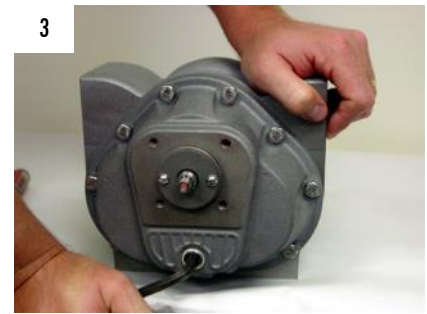

### Removing Packing Capsule

- 1) Remove the retaining plate using a standard flathead screwdriver.
- 2) Pull out the packing gland from the meter.

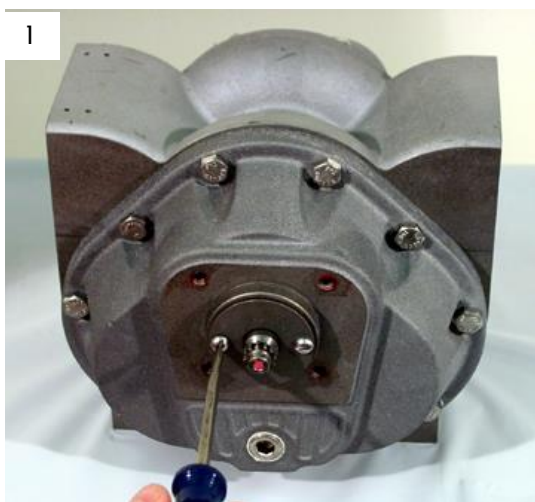

## Disassembly of Meter (Continued)



### Front & Rear Cover

- 1) Remove the screws on the front cover using a socket or box wrench.
- 2) Remove front cover.
- 3) Remove the screws on the back and remove rear cover.
- 4) Remove the O-ring from both sides of the housing

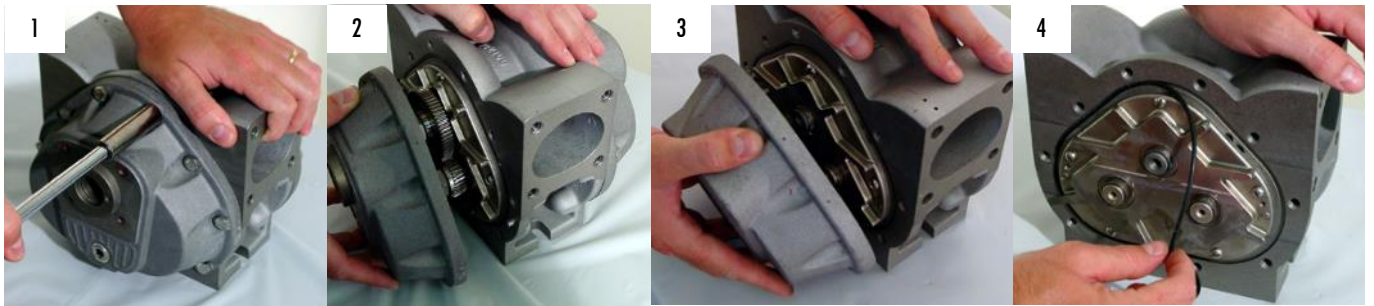

### Rotor Gears

- 1) Using a spare displacement rotor gear, place it between the rotor and blocking gear on the meter.
- 2) Use the socket or box wrench to loosen the right rotor gear lock nut. Repeat for the left rotor gear lock nut.
- 3) Move the spare displacement rotor gear to the other side and loosen the blocking rotor lock nut.

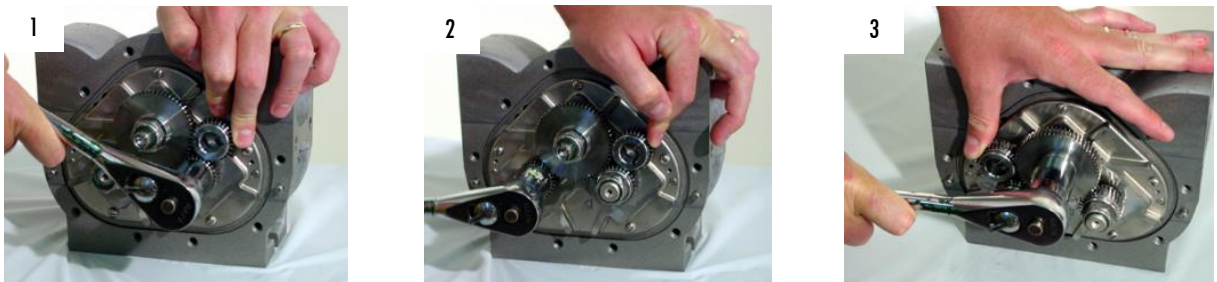

### Special Notes

- 1) DO NOT remove rotor gears using a screwdriver! This could damage the rotor gear and create potential wear problems within the measuring chamber.
- 2) If a spare rotor gear is not available, then use shop rag between gear teeth.





## Disassembly of Meter (Continued)



### Removing Bearing Plate

- 1) Remove the bearing plate retaining screws with a standard flathead screwdriver.
- 2) To remove bearing plate & rotors, insert a screwdriver into the notches near the dowel pins.
- 3) Gently pry the bearing plate off the dowel pins and slide out the bearing plate and rotors from the housing.

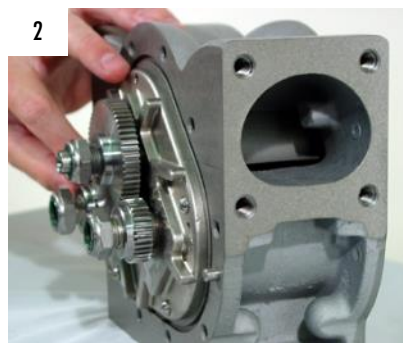
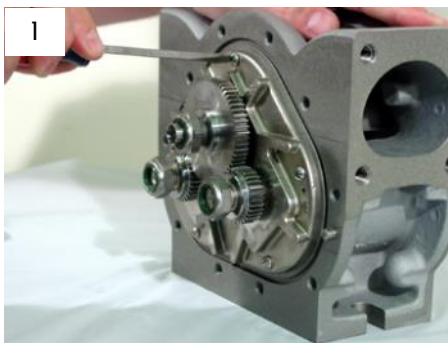

### Removing Lock Nuts & Rotors

- 4) Remove rotor lock nuts from each gear.
- 5) Pull gears off of rotor shaft.
- 6) Remove rotor key using pliers (this might not be necessary as rotor may slide right out of bearing plate).
- 7) Remove rotors from bearing plate.

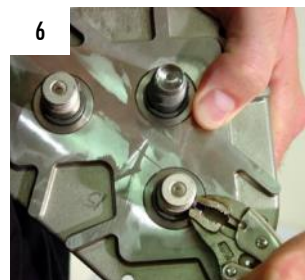



## Inspection of Parts



- 1) Inspect the surfaces of rotors, bearing plates, meter housing and gear teeth for any damage or wear.
- 2) Replace parts as needed.

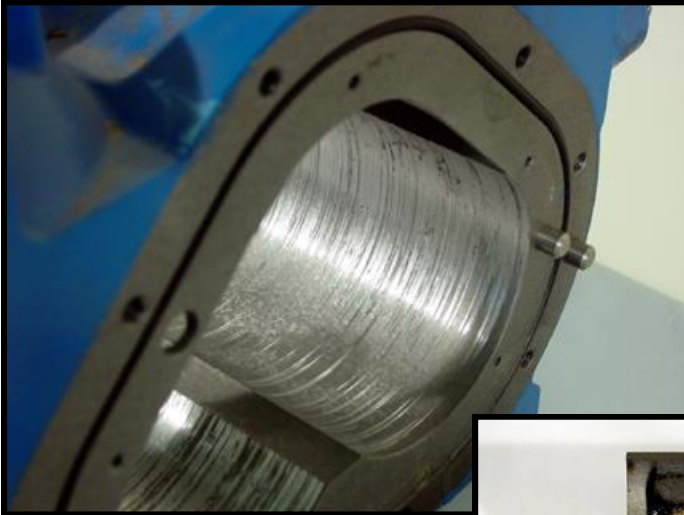

**CHAMBER WEAR**

- A) Foreign debris, similar to sand or sludge, has run through the meter.
- B) Meter has been operated at a higher capacity and has worn the bearings out, allowing rotors to drop into the chamber



**GEAR WEAR**

- A) Meter has been run on air.
- B) Meter has been operated at a higher volume capacity than what is rated.

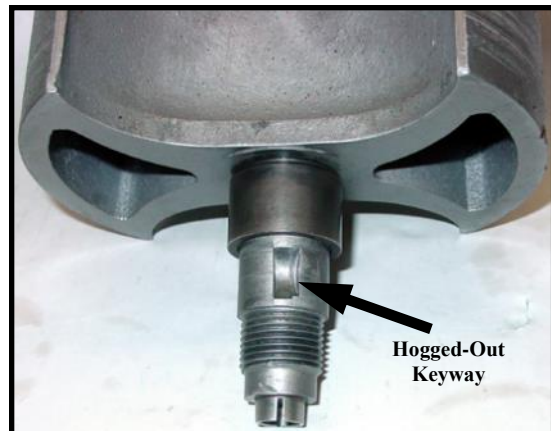
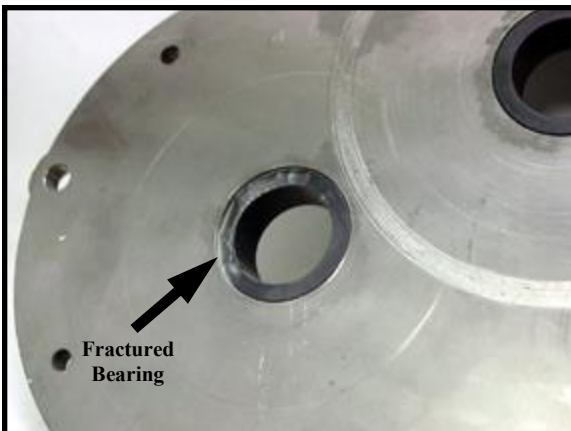

**HYDRAULIC SHOCK**

- A) A valve downstream of the flow meter has abruptly shut off, creating hydraulic shock.
- B) Flow meter potentially had large volume of free air flowing within the system, followed by fluid.

## Reassembly of Meter



### Reinstalling Rotors

- 1) Install rear bearing plate on meter.
- 2) Insert threaded end of blocking rotor and the right displacement rotor into front gear plate (reinsert rotor keys if necessary).
- 3) Align the two rotors (see picture 3) before applying gears.



### Rotor Gear Timing

- 1) Slide on blocking rotor gear and position the 'arrow' that it is pointing toward the right displacement gear.
- 2) Align 'arrow' on displacement gear with the 'arrow' on the blocking gear and slide on right displacement gear.
- 3) Rotate the blocking rotor gear toward the left displacement gear and again align 'arrows' and slide on left displacement gear.
- 4) Gears and rotors should rotate freely if gears have been installed properly. If so, proceed with starting on the lock nuts until finger tight.

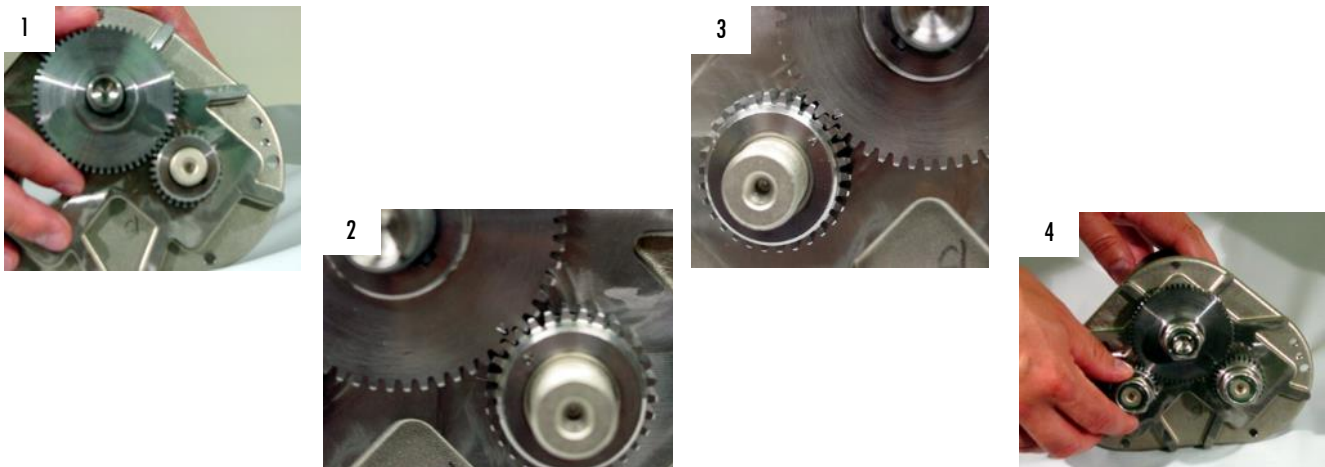

## Reassembly of Meter (Continued)

### Reinstalling Bearing Plate

- 1) Align rotors on bearing plate (see picture) before inserting into meter.
- 2) Slide front bearing plate with rotors into meter housing and rear bearing plate.
- 3) Again, rotate gears to make sure they turn freely within the housing before proceeding.

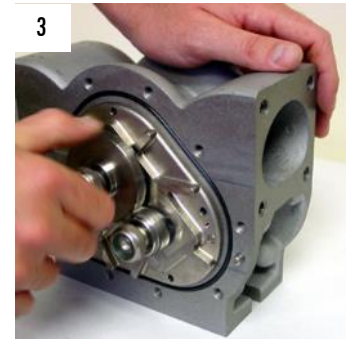
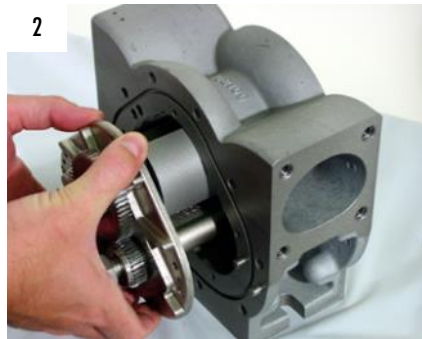
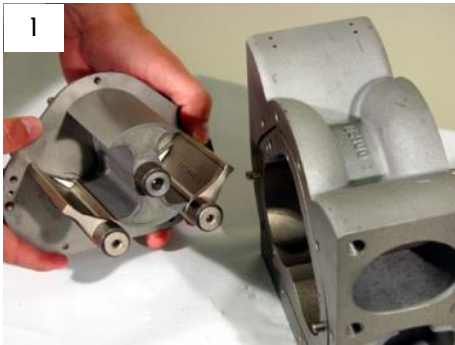

### Reinstalling Rotor Gears & Lock Nuts

- 1) Using the spare displacement gear (or shop rag), position between right displacement gear and blocking rotor gear.
- 2) Using the torque specifications, apply and tighten the lock nut on the right and left displacement gears.
- 3) Move the spare gear between the left displacement and blocking rotor gears and then tighten the lock nut on the blocking rotor gear.

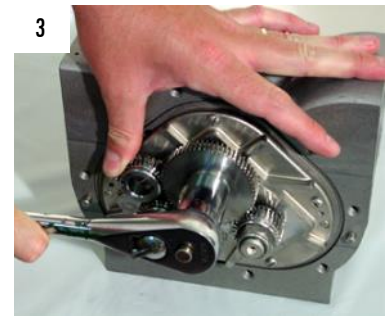
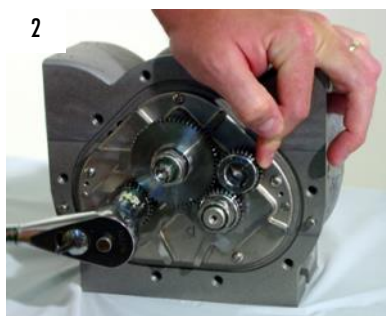
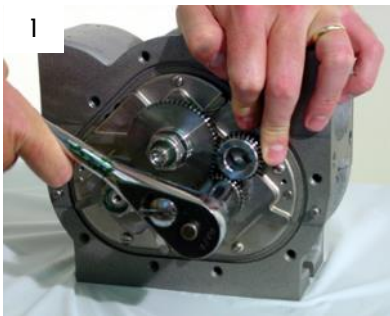



## Reassembly of Meter (Continued)

### Reinstalling Packing Capsule & Front/Rear Covers

- 1) Reinstall cover O-rings on the front and rear of meter housing.
- 2) Reinsert packing capsule into front cover of meter with retaining plate and tighten screws.
- 3) When attaching front cover, align packing capsule blade with the slot on the blocking rotor sleeve. Tighten all front cover screws.
- 4) Attach rear cover and tighten all screws.

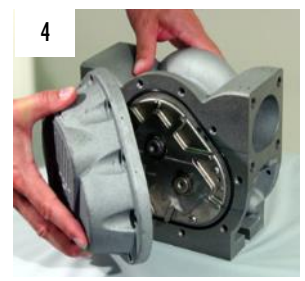
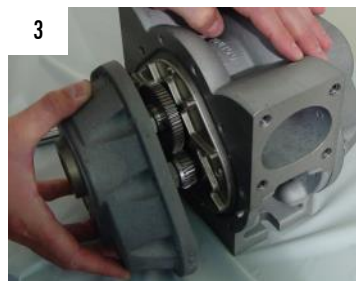
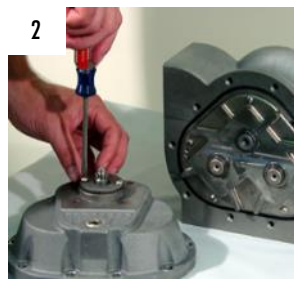
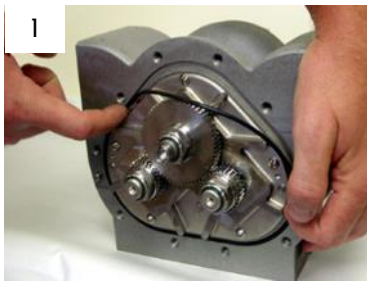

### Reinstalling Counter Support & Adjuster Drive Shaft

- 1) Position the counter support on the front side of meter and tighten all screws.
- 2) Reinsert adjuster drive shaft into the support housing. Assure that adjuster face gear teeth mesh completely with the packing capsule gear. The face gear and packing gear should mesh snugly, but do not overtighten as this will cause premature wear on the gears.
- 3) Slide down the adjuster mounting bracket and tighten the screws.

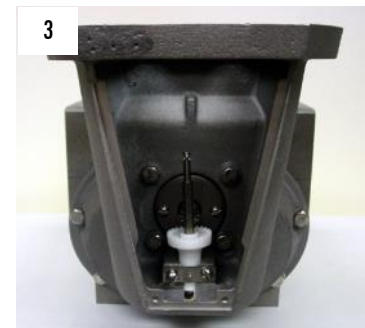
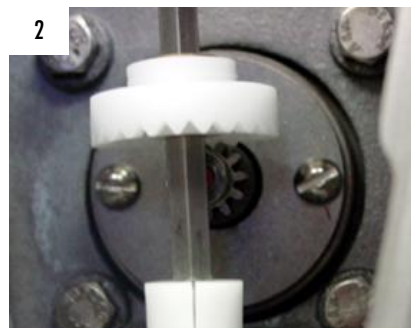

## Reassembly of Meter (Continued)

### Reinstalling Adjuster

- 1) Reinsert the adjuster into the top of the counter support and assuring that it mates with the drive shaft.
- 2) Tighten the screws that secure the adjuster plate to the counter support.



### Reinstalling Dust Cover

- 1) Reattach dust cover and tighten the screws.
- 2) Back where we started.

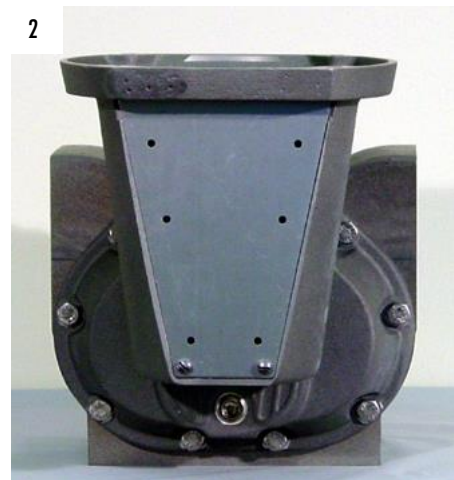
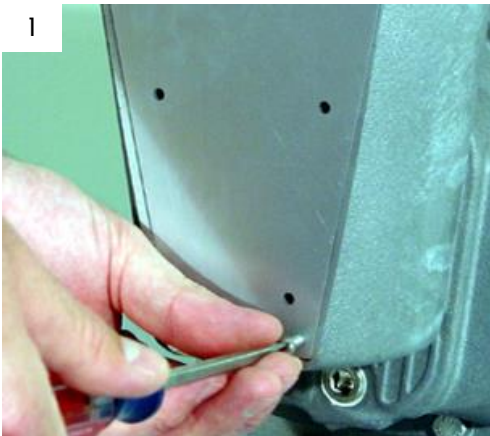

## Disassembly of 720-20 Strainer Assembly

### ***!WARNING!***

All internal pressure must be relieved to ZERO (0) pressure before beginning disassembly of meter or components

- 1) Using a hex or socket wrench, remove the four screws and washers from the cover plate.
- 2) Remove the cover plate and O-ring from the housing.
- 3) Remove the strainer screen.
- 4) Check inside housing for any debris and remove using a clean cloth.
- 5) Clean strainer screen by rinsing with a liquid cleaning agent compatible to your product application. A brush may be used to remove imbedded particles. If screen is too dirty to clean, then replace the screen.
- 6) Wipe clean the face of the cover plate and seal ring. Check O-rings for damage and replace as needed.

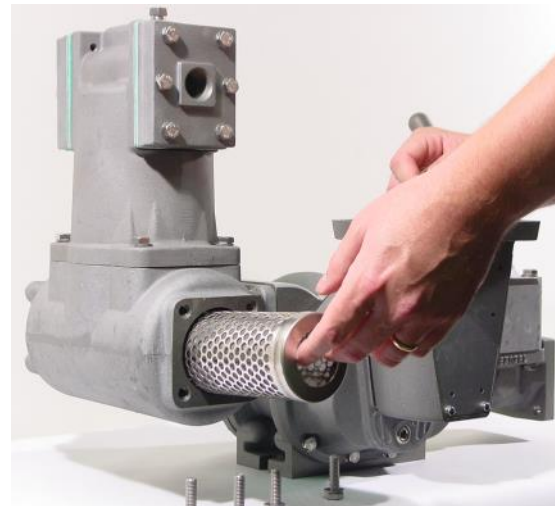
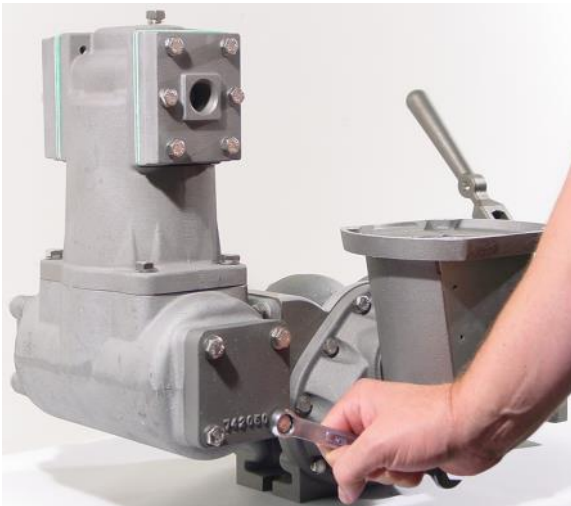

## Reassembly of 720-20 Strainer Assembly

- 1) Replace the strainer screen into the housing.
- 2) Place the end cover O-ring in the groove of the end cover.
- 3) Put the end cover with O-ring installed on the strainer housing. Replace and fasten end cover with the 4 screws and washers. Tighten the screws according to the torque chart.

## Disassembly of 730LP Vapor Eliminator



### ***!WARNING!***

All internal pressure must be relieved to ZERO (0) pressure before beginning disassembly of meter or components

- 1) Using a 1/2" wrench or socket, remove the cover screws from air eliminator cover plate.
- 2) Remove cover plate.
- 3) Remove valve plate, inspect and replace as needed.

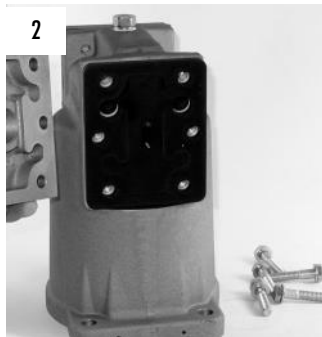

- 1) To remove the air eliminator assembly, remove the four screws and washers attaching it to the strainer assembly.
- 2) Using a flathead screwdriver, remove the screws attaching reed valves to air eliminator housing.
- 3) Remove the two screws on the diffuser screen.
- 4) Slide out diffuser shaft assembly.
- 5) Remove the two screws attaching reed valve to the float assembly. Inspect and replace reed valves as needed.

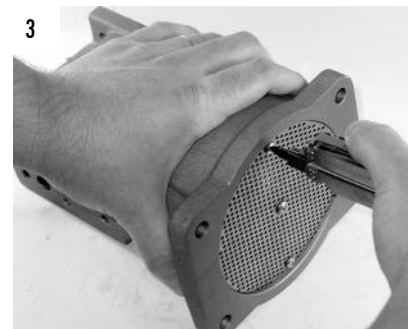
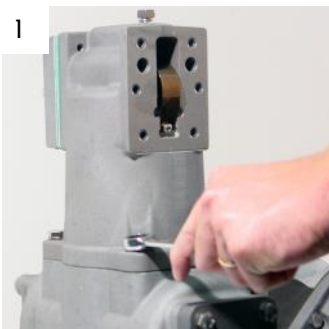



# Assembly of 757-20LP Differential Valve



## ***!WARNING!***

All internal pressure must be relieved to ZERO (0) pressure before beginning disassembly of meter or components

### DIAPHRAGM ASSEMBLY

- 1) Insert O-rings (#10) on top and bottom of diaphragm poppet (#11).
- 2) Thread seat (#12) onto diaphragm poppet (#11) with cylindrical side closest to poppet.
- 3) Install spring retainer (#6) onto diaphragm adaptor (#5).
- 4) Place O-ring (#7) over shaft of diaphragm adaptor (#5) and up to spring retainer (#6) surface.
- 5) Insert diaphragm back-up plate (#8) with bevel up over shaft of diaphragm adaptor (#5).
- 6) Place diaphragm (#15) with bevel down, onto diaphragm adaptor (#5).
- 7) Insert diaphragm back-up plate (#8) with bevel Down, over shaft of diaphragm adaptor (#5).

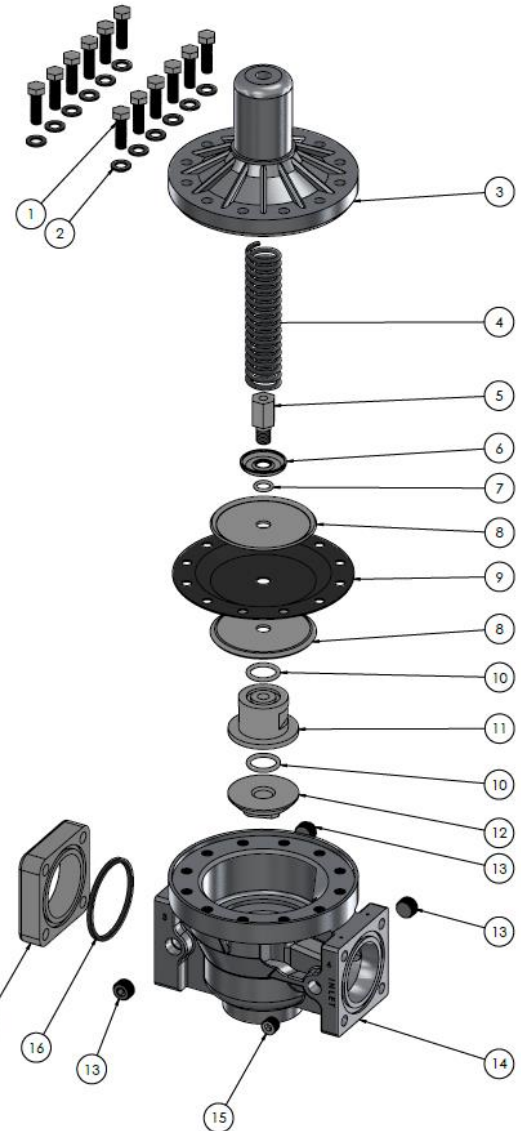

### FINAL ASSEMBLY

- 1) Insert diaphragm assembly into valve base assembly (#14) with diaphragm adaptor (#5) up.
- 2) Place spring (#4) over diaphragm adaptor (#5).
- 3) Install valve cap (#3) on top of spring (#4).
- 4) Insert threaded rod (#) into top of valve cap (#3) and thread rod down into diaphragm adaptor (#5) so 4-10 threads are engaged.
- 5) Place fender washer (TCS 5/16FENDER) onto threaded rod (TCS 757060).
- 6) Thread nut (TCS 757070) onto thread rod (TCS 757060).
- 7) Tighten nut (TCS 757070) down until the spring (#4) becomes depressed enough to get the bolts (#1) started.
- 8) Place 1 washer (#2) on each of 4 bolts (#1) and put them into valve cap (#3) at an equal distance from one another.
- 9) Using the torque specifications on page 30, tighten the 4 bolts (#1) down.
- 10) Remove threaded rod (TCS 757060), fender washer (TCS 5/16FENDER), and nut (TCS 757070) from unit.
- 11) Insert the remaining washers (#2) and bolts (#1) into the valve cap (#3).
- 12) Using the torque specifications on page 30, tighten the remaining bolts (#1) down.
- 13) Check to make sure all bolts (#1) are tightened to torque specs when finished.

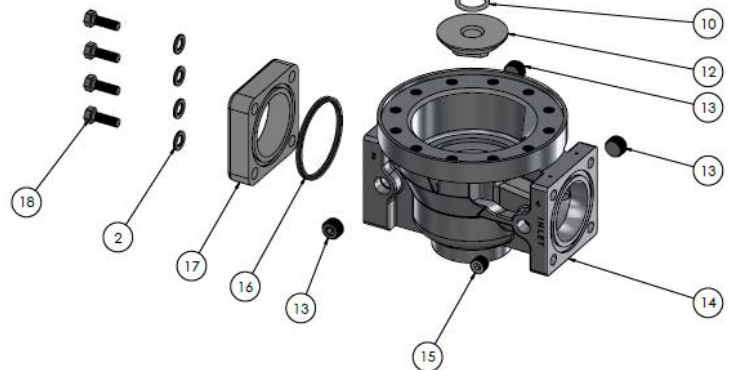

## Assembly of 782-20LP Check Valve



### ***!WARNING!***

All internal pressure must be relieved to ZERO (0) pressure before beginning disassembly of meter or components

### CHECK VALVE ASSEMBLY

- 1) Insert pressure relief valve (#2) into valve housing (#1).
- 2) Slide piston ring (#4) onto valve housing (#3).
- 3) Place O-ring (#6) over shaft of valve housing (#3) and up to piston ring (#4) surface.
- 4) Install spacer (#7) over shaft of valve housing (#3) and over O-ring (#6).
- 5) Insert O-ring (#5) into groove of O-ring retainer (#8).
- 6) Slide O-ring retainer (#8) over shaft of valve housing (#3).
- 7) Using the torque specifications, apply and tighten the nut (#9) on the valve housing (#3).
- 8) Install assembly into housing (#1) with O-ring facing pipe threads of housing (#1).
- 9) Press bearing sleeve (#12) into spring holder (#11).
- 10) Insert spring holder (#11) into housing (#1) with cylinder facing pipe threads.
- 11) Install retaining ring (#13) into groove of housing (#1).

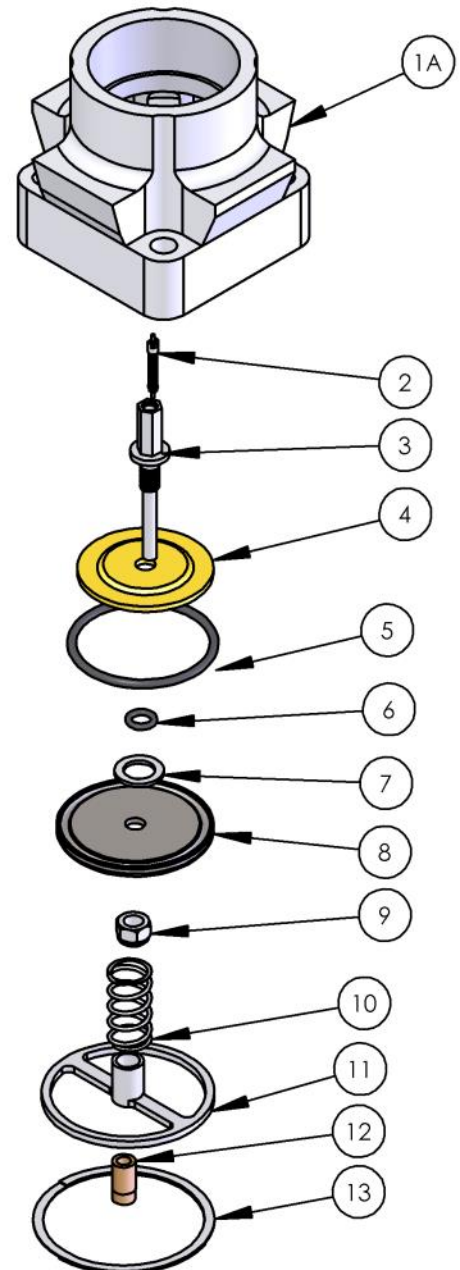

## Meter Trouble Shooting



### PROBLEM: Leaking packing gland and/or housing

Check to see whether any O-Rings have been damaged or cover bolts have not been tightened enough.

Two common causes of packing gland leakage are thermal expansion and hydraulic shock.

If two valves in a piping system (on either side of the meter) are closed, isolating the meter, and if the temperature rises as little as 1°F in the system, the possible rise in pressure due to temperature would exceed the working pressure rating of the meter. To avoid this hazard caused by thermal expansion, a pressure-relief valve must be installed in the system near the meter.

Hydraulic shock occurs when a large volume (mass) of liquid is moving through a pipe line at normal operating flow rate and a valve is suddenly closed. When the flow is so suddenly stopped, the entire mass of the liquid in the piping system acts as a battering ram, causing a shock effect within the meter. The greater the mass, length of line and/or velocity, the greater the hydraulic shock. Since the valve is usually located at the meter outlet, the meter housing, packing gland and the meter internal components receive the full impact of this hydraulic shock. To prevent this hazard, a slow closing two-stage valve should be used in conjunction with the metering system. On those systems where mass, length of line, etc. are of such magnitude as to preclude the elimination of hydraulic shock with the use of a two-stage slow closing valve, an impact-absorbing air cushioning device should be used.

### PROBLEM: Product flows through meter but register does not operate.

- A) Gear train motion interrupted by non-functioning gear due to broken pin or key. Replace pin or key where required.
- B) If all meter parts are moving then problem is in register.
- C) Remove register from meter. If all meter parts are moving but output shaft of adjuster assembly is not, adjuster is worn and must be replaced.
- D) If totalizer numerals (small numbers) on register are recording, but the big numerals are not moving, register needs repair.

### PROBLEM: Product flows through meter but register does not record correctly.

- A) Adjuster assembly not properly calibrated, See METER CALIBRATION on page 11 to 13 for more instructions.
- B) The factory installed gear train may have incorrect gearing ratio.
- C) Check register for defects.

### PROBLEM: No flow through meter.

- A) Faulty non-functioning pump.
- B) Foreign matter within the system, meter or components.
- C) Meter has a broken rotor or rotor shaft.
- D) Excessive wear on timing gears or bearings.
- E) Meter “frozen” due to build-up of chemical “salts” inside metering chamber, sufficient to stop rotation of rotors.
- F) Valve not open or not functioning.

### PROBLEM: Meter runs too slow.

- A) There is a flow restriction within the system (tees, elbows, valves, etc.)
- B) Foreign matter in system, meter or components.
- C) Product viscosity is different or has changed from what was originally known.
- D) Meter gears or rotors partially “salted” enough to slow up rotation of parts.
- E) Valve internal mechanism faulty. Valve does not open fully or the linkage is not properly adjusted.

## Vapor Eliminator Trouble Shooting



PROBLEM: Product is flowing from the Air Eliminators vents

- A) Foreign matter located in between seal plate orings and metal reeds.
- B) The seal plate may be worn through service life.
- C) The seal plate may be cut and requires replacement.
- D) The float may have been punctured, containing liquid, not allowing the float to rise and seal the air vents.
- E) The float may have been ruptured from a surge of pressure within the system.
- F) The metal reeds may be fatigued and requires replacement.
- G) The metal reeds may be out of alignment with the seal plate.

PROBLEM: The meter is still registering air within the system

- A) The air return line is not the required minimum of 1/2" ID.
- B) The metering system has insufficient means of eliminating air to the atmosphere. Some examples: An incorrectly installed "Catch Can" reservoir is located lower than the air eliminator itself. The reservoir is allowed to become full or the vent is improperly sized.

There can be numerous reasons why the meter may still register air. First look at the system configuration and see where air is being introduced into the system. Then determine if the meter is registering "free air" or "entrained air". Free Air is much easier to remove from the metering system and may require the use of a Spring Loaded Back Check Valve and/or a Differential Air Check Valve and/or a High Volume Strainer to help the air eliminator operate more effectively.

Entrained Air is much more difficult to remove. Typically the best way to eliminate Entrained Air will be to remove the source of entry of air into the system. Some typical examples would be a cavitating pump or a leaking pump or faulty valve seals. A High Volume Strainer may help accumulate the liquid long enough to disperse the Entrained Air from the system. See Air Elimination in the Service Manual for more information.

## Differential Valve Trouble Shooting



PROBLEM: Valve fails to open

- A) Damaged vapor return line with no pressure relief from Valve Cap (Bonnet)
- B) Puncture or Tear in Valve Diaphragm

PROBLEM: Product continues to flow through valve

- A) Valve Seat has excessive wear or is damaged.
- B) Valve Poppet is not secure and requires tightening.
- C) Faulty Solenoid Valve (foreign material or ice).

# Material Safety Data Sheet

24 HOUR EMERGENCY ASSISTANCE  
(260) 833-3173

GENERAL MSDS ASSISTANCE  
(260) 484-0301

CODE: RPS

HAZARD RATING-> LEAST-0 SLIGHT-1 MODERATE-2 HIGH-3 EXTREME-4

DR LUBRICANTS, INC.  
4611 NEWAYGO ROAD, SUITE D  
FORT WAYNE, IN 46808

DATE: 01/21/06

TELEPHONE NUMBER: (260 484-0301

## SECTION I - PRODUCT IDENTIFICATION

PRODUCT: **RP 1060**

## SECTION II - COMPOSITION AND HAZARDOUS INFORMATION\*

CHEMICAL NAME	CAS NUMBER	WT. PERCENT IS LESS THAN	OCCUPATIONAL EXPOSURE LIMITS (TLV-TWA) (TLV-STEL)
PETROLEUM HYDROCARBON	64741-65-7	45.0	100MG/M3
PETROLEUM HYDROCARBON	64742-53-6	65.0	5MG/M3

\*ITEMS NOT SHOWN ARE NOT LISTED IN THE OSHA - T.S.C.A. HAZARDOUS CHEMICALS LISTING.

## SECTION III - PHYSICAL DATA

BOILING RANGE:	NA	VAPOR DENSITY:	NA
ODOR:	PETROLEUM ODOR	EVAPORATION RATE:	NA
APPEARANCE	AMBER LIQUID	SOLUBILITY:	INSOLUBLE
VOLATILE BY WEIGHT:	NA	PRODUCT DENSITY:	0.829
VOLATILE BY VOLUME:	NA		

## SECTION IV - FIRE AND EXPLOSION HAZARD DATA

FLAMMABILITY CLASSIFICATION:	COMBUSTIBLE	FLASH POINT:	170 F (CLEVELAND OPEN CUP)	LEL:	NA
DOT:	COMBUSTIBLE LIQUID			UEL:	NA
EXTINGUISHING MEDIA:	CARBON DIOXIDE, DRY CHEMICAL, FOAM				

## SECTION IV - FIRE AND EXPLOSION HAZARD DATA

UNUSUAL FIRE AND EXPLOSION HAZARDS : DO NOT DIRECT A SOLID STREAM OF WATER ONTO BURNING PRODUCT. THIS MAY CAUSE SPREADING AND INCREASE THE FIRES INTENSITY. COMBUSTION MAY PRODUCE: OXIDES OF CARBON, AND INCOMPLETELY BURNED HYDROCARBONS IN THE FORM OF FUMES AND SMOKE.

SPECIAL FIREFIGHTING PROCEDURES: WEAR A SELF-CONTAINED BREATHING APPARATUS WITH FULL FACEPIECE.

## SECTION V - HEALTH HAZARD DATA

EFFECTS OF OVER EXPOSURE: MAY CAUSE MILD EYE IRRITATION AND REDNESS. PROLONGED OR REPEATED EXPOSURE TO THE SKIN MAY RESULT IN LOSS OF NATURAL OILS ACCOMPANIED BY DRYNESS, CRACKING AND DERMATITIS. INGESTION MAY RESULT IN NAUSEA, DIARRHEA AND GASTRO INTESTINAL IRRITATION. OVEREXPOSURE TO MIST MAY CAUSE UPPER RESPIRATORY TRACT IRRITATION AND DIFFICULTY BREATHING.

MEDICAL CONDITIONS PRONE TO AGGRAVATION BY EXPOSURE: NONE KNOWN.

PRIMARY ROUTE(S) OF ENTRY: DERMAL INHALATION INGESTION.

EMERGENCY AND FIRST AID PROCEDURES: IN CASE OF EYE CONTACT, IMMEDIATELY FLUSH EYES WITH CLEAN WATER FOR AT LEAST 15 MINUTES. IF EYE IRRITATION PERSISTS, CONTACT A PHYSICIAN. IN CASE OF SKIN CONTACT, REMOVE ANY CONTAMINATED CLOTHING AND RINSE SKIN THOROUGHLY WITH WATER FOR AT LEAST 15 MINUTES. IF SKIN IRRITATION PERSISTS, CONTACT A PHYSICIAN. IN CASE OF OVEREXPOSURE TO MIST, REMOVE VICTIM TO FRESH AIR: IF BREATHING IS DIFFICULT ADMINISTER OXYGEN: AND CONTACT A PHYSICIAN IMMEDIATELY. IF PRODUCT IS INGESTED DO NOT INDUCE VO MITING: CONTACT A PHYSICIAN.

# Material Safety Data Sheet (Continued)

---

---

## SECTION VI - REACTIVITY DATA

---

---

STABILITY: THIS PRODUCT IS STABLE UNDER NORMAL STORAGE CONDITIONS.

HAZARDOUS POLYMERIZATION: WILL NOT OCCUR UNDER NORMAL CONDITIONS.

HAZARDOUS DECOMPOSITION PRODUCTS: THERMAL DECOMPOSITION MAY RESULT IN THE FORMATION OF: OXIDES OF CARBON, AND INCOMPLETELY BURNED HYDROCARBONS IN THE FORM OF FUMES AND SMOKE.

CONDITIONS TO AVOID: AVOID CONTACT WITH OPEN FLAME, STORE IN ROOM TEMPERATURE AREA.

INCOMPATIBILITY: AVOID CONTACT WITH STRONG OXIDIZING AND REDUCING AGENTS AND STRONG ALKLI.

---

---

## SECTION VII - SPILL OR LEAK PROCEDURES

---

---

STEPS TO BE TAKEN IN CASE MATERIAL IS RELEASED OR SPILLED: FOR SMALL SPILLS: SOAK UP SPILL WITH ABSORBENT MATERIAL. FOR LARGE SPILLS: DIKE SPILL AND PUMP INTO DRUMS FOR PROPER DISPOSAL.

WASTE DISPOSAL METHOD: DISPOSE OF IN ACCORDANCE WITH ALL LOCAL STATE AND FEDERAL REGULATIONS.

---

---

## SECTION VIII - SAFE HANDLING AND USE INFORMATION

---

---

RESPIRATORY PROTECTION: NORMALLY NOT REQUIRED, HOWEVER, WHEN THE TLV IS EXCEEDED WEAR THE APPROPRIATE MSHA/NIOSH APPROVED RESPIRATOR.

VENTILATION: PROVIDE ADEQUATE VENTILATION (SUCH AS MECHANICAL OR LOCAL) TO ASSURE TLV IS NOT EXCEEDED.

PROTECTIVE GLOVES: NORMALLY NOT REQUIRED, HOWEVER, IF HANDS ARE FREQUENTLY IN FLUID WEAR OIL AND CHEMICAL IMPERVIOUS GLOVES.

EYE PROTECTION: SAFETY GLASSES REQUIRED FOR NORMAL USAGE, WEAR CHEMICAL GOGGLES WHEN EXCESSIVE SPLASHING MAY OCCUR.

OTHER PROTECTIVE EQUIPMENT: NORMALLY NOT REQUIRED, HOWEVER, WHERE REPEATED CONTACT OCCURS, WEAR IMPERVIOUS CLOTHING AND BOOTS.

HYGIENIC PRACTICES: FOLLOW STANDARD INDUSTRIAL HYGIENE PRACTICES. LAUNDRY ANY CONTAMINATED CLOTHING BEFORE RE-USE.

---

---

## SECTION IX - SPECIAL PRECAUTIONS

---

---

PRECAUTIONS TO BE TAKEN IN HANDLING AND STORAGE: DO NOT STORE IN THE PRESENCE OF HEAT, SPARKS, FLAME OR ANY OTHER SOURCES OF IGNITION. STORE AWAY FROM STRONG OXIDIZING AGENTS. EMPTY DRUMS MAY CONTAIN PRODUCT RESIDUES. ALL SAFETY PRECAUTIONS TAKEN WHEN HANDLING THIS PRODUCT SHOULD ALSO BE TAKEN WHEN HANDLING EMPTY DRUMS AND CONTAINERS.

OTHER PRECAUTIONS: NONE

---

---

## SECTION X - HMIS/NFPA RATINGS

---

---

HMIS:HEALTH:1 FLAMMABILITY:2 REACTIVITY:0 PERSONAL PROTECTION:C

NFPA:HEALTH:1 FLAMMABILITY:2 REACTIVITY:0 SPECIFIC HAZARD:

---

---

## SECTION XI - OTHER REGULATORY INFORMATION

---

---

LAND (TDG)

PROPER SHIPPING NAME: PETROLEUM DISTILLATES, N.O.S.

HAZARD CLASS & DIVISION: 3

UN NUMBER: 1268

PACKING GROUP: III

---

---

THE INFORMATION CONTAINED HEREIN IS, TO THE BEST OF OUR KNOWLEDGE AND BELIEF, ACCURATE. HOWEVER, SINCE THE CONDITIONS OF HANDLING AND USE ARE BEYOND OUR CONTROL, WE MAKE NO GUARANTEE OF RESULTS, AND ASSUME NO LIABILITY FOR DAMAGES INCURRED BY USE OF THIS MATERIAL. IT IS THE RESPONSIBILITY OF THE USER TO COMPLY WITH ALL APPLICABLE FEDERAL, STATE AND LOCAL LAWS AND REGULATIONS.

---

---



## Warranty Information

New 700 rotary meters, equipment or components manufactured by Total Control Systems, a division of Murray Equipment, Inc. (TCS) with which this warranty is enclosed, are warranted by TCS to the original purchaser only for a period of TWELVE (12) months from installation or eighteen (18) months from the date of shipment, to be free, under normal use and service, from defects in material and workmanship.

Defects occurring within the stated warranty period, TCS will repair or replace, at TCS's option; provided that part or parts are returned to TCS transportation charges prepaid, and TCS's examination discloses the parts or workmanship to have been defective upon delivery to the purchaser.

**EXCLUSIONS:** Warranty does not cover any parts and equipment not manufactured by TCS, but these items may be covered by separate warranties of their respective manufacturers. This warranty does not extend to any equipment that has been subjected to misuse, negligence or accident or if operated in any manner other than in accordance with TCS's operating instructions and specifications.

**CLAIM PROCEDURES:** In order to obtain performance by TCS of its obligations under this warranty, the original purchaser must obtain a Return Goods Authorization (RGA) number from TCS's customer service department within 30 days of discovery of a purported breach of warranty, but not later than the expiration of the warranty period. Once authorization is received, return the RGA and defective meter, piece of equipment, or component covered by this warranty, with transportation charges prepaid, to TCS together with a written RGA form, MSDS sheet and packaging clearly marked with the RGA number. All RGA procedures must strictly be followed for safety and quick resolve. TCS reserves the right of refusal for shipments sent back freight collect and/or without proper paperwork.

**LIMITATIONS:** There are no other warranties of any kind, expressed or implied. TCS specifically disclaims any warranty of merchantability or of fitness for any particular purpose. TCS will determine if all parts or meter defect falls within the warranty guidelines and will repair or replace within a reasonable time span. TCS is not responsible for any in or out bound freight. TCS's sole obligation shall represent the buyer's sole and exclusive remedy shall be to repair or at TCS's option to replace any product or part determined to be defective. In no event shall TCS be liable for any special, direct, indirect, incident, consequential or other damages of similar nature, including without limitation, loss of profits, products, production time, or loss of expenses of any nature incurred by the buyer or any third party. TCS has not authorized on its behalf any representation or warranties to be made, nor any liability to be assumed except as expressly provided herein; there is no other express or implied warranty.

**REPAIR WARRANTY:** All repair work is warranted for ninety (90) days from the date of shipment to customer. Some parts may be warranted for longer periods by the Original Equipment Manufacturer.

**DESIGN AND EQUIPMENT CHANGES:** Any changes in design or improvements added shall not create any obligation to install same on equipment previously sold or ordered.



2515 Charleston Place  
Fort Wayne, IN 46808

Toll Free: (800) 348-4753  
Phone: (260) 484-0382  
Fax: (260) 484-9230  
Email: [sales@tcsimeters.com](mailto:sales@tcsimeters.com)

Check us out at [www.TCSimeters.com](http://www.TCSimeters.com)!